



R32 TOP-DISCHARGE HEAT PUMP CONDENSER INSTALLATION MANUAL





Models Covered:
ACiQ-24TD-HP32
ACiQ-36TD-HP32
ACiQ-48TD-HP32
ACiQ-60TD-HP32



Installation must be performed in accordance with the requirements of NEC and CEC by authorized personnel only.
All phases of this installation must comply with National, State and Local Codes.

VERSION DATE: 02-24-26

Safety Notice

 A2L  A2L	Caution: Risk of fire. The air conditioner is charged with inflammable refrigerant R32.
	Before using the air conditioner, please read the instruction manual first.
	Before installing the air conditioner, please read the instruction manual first.
	Before repairing the air conditioner, please read the technical service manual first.

Compared with common refrigerant, R32 is an environmental-friendly refrigerant that has no harm to the ozone layer and weak greenhouse effect. Its GWP is 675. Because of its thermodynamic characteristics, R32 requires a smaller charging quantity to reach high energy efficiency. It is inflammable and odorless, but may cause explosion under certain circumstances.

CONTENTS

Precautions	1
Instruction for Servicing (R32)	4
Unit Location Considerations	20
Refrigerant Line Consideration	23
Refrigerant Line Routing	26
Refrigerant Line Brazing	27
System Leak Check	30
Evacuation	30
Service Valves	31
Electrical-Low Voltage	32
Electrical-High Voltage	34
Start-Up	36
System Operation	37
Troubleshooting	41
Wiring Diagram	43
Disposal Guideline	45

Precautions

SAFETY RULES AND RECOMMENDATIONS FOR THE INSTALLER

1. **R**ead this guide before installing and using the appliance.
2. **D**uring the installation of the indoor and outdoor units, access to the working area should be forbidden to children. Unforeseeable accidents could happen.
3. **M**ake sure that the base of the outdoor unit is firmly fixed.
4. **C**heck that air cannot enter the refrigerant system and check for refrigerant leaks before turning on the air conditioner.
5. **C**arry out a test cycle after installing the air conditioner and record the operating data.
6. **P**rotect the unit with a fuse of suitable capacity for the maximum input current or with another overload protection device.
7. **E**nsure that the mains voltage matches the voltage indicated on the nameplate. Keep the switch clean and ensure that the power cord terminals are correctly connected to the circuit. This prevents the risk of electric shock or fire caused by poor contact.
8. **T**he appliance must be equipped with devices capable of disconnection from the mains power supply, have a contact separation in all poles to provide full disconnection under "over voltage category III conditions", these devices must also be incorporated into the fixed wiring in accordance with the wiring rules.
9. **T**he air conditioner must be installed by professional or qualified persons. Do not try to install the conditioner alone, always contact specialized technical personnel.
10. **D**o not install the appliance at a distance of less than 50 cm from inflammable substances (alcohol, etc.) or from pressurized containers (e. g. spray cans).
11. **I**f the appliance is used in areas without the possibility of ventilation, precautions must be taken to prevent any leaks of refrigerant gas from remaining in the environment and creating a danger of fire.
12. **T**he packaging materials are recyclable and should be disposed of in the separate waste bins. Take the air conditioner at the end of its useful life to a special waste collection center for disposal.
13. **O**nly use the air conditioner as instructed in this booklet. These instructions are not intended to cover every possible condition and situation. As with any electrical household appliance, common sense and caution are therefore always recommended for installation, operation and maintenance.
14. **T**he appliance must be installed in accordance with applicable national regulations.
15. **B**efore accessing the terminals, all the power circuits must be disconnected from the power supply.

-
16. **T**his appliance can be used by children aged from 8 years and above and persons with reduced physical, sensory or mental capabilities or lack of experience and knowledge if they have been given supervision or instruction concerning use of the appliance in a safe way and understand the hazards involved. Children should not play with the appliance. Cleaning and user maintenance should not be made by children without supervision.
 17. **C**leaning and maintenance must be carried out by specialized technical personnel. In any case disconnect the appliance from the mains electricity supply before carrying out any cleaning or maintenance.
 18. **T**his appliance has been made for air conditioning domestic environments and must not be used for any other purpose, such as for drying clothes, cooling food, etc.
 19. **A**lways use the appliance with the air filter mounted. Air conditioning without air filter could cause an excessive accumulation of dust and/or lead to inner parts function failure.
 20. **T**he user is responsible for having the appliance installed by a qualified technician, who must check that earthing/grounding is done in accordance with current legislation and insert a thermal-magnetic circuit breaker.
 21. **T**he batteries in the remote controller must be recycled or disposed of properly. For disposal of scrap batteries, please discard the batteries as sorted municipal waste at the accessible collection point.
 22. **N**ever remain directly exposed to the flow of cold air for a long time. The direct and prolonged exposure to cold air could be dangerous for your health. Particular care should be taken in the rooms where there are children, old or sick people.
 23. **I**f the appliance gives off smoke or there is a smell of burning, immediately cut off the power supply and contact the Service Center. The prolonged use of the device in such conditions could cause fire or electrocution.
 24. **H**ave repairs carried out only by an authorised Service Center of the manufacturer. Incorrect repair could expose the user to the risk of electric shock, etc.
 25. **U**nhook the switch if you foresee not to use the device for a long time. The airflow direction must be properly adjusted.
 26. **T**he flaps must be directed downwards in the heating mode and upwards in the cooling mode.
 27. **E**nsure that the appliance is disconnected from the power supply when it is intended to remain inoperative for a long period and before carrying out any cleaning or maintenance.
 28. **S**electing the most suitable temperature can prevent damage to the appliance.

SAFETY RULES AND PROHIBITIONS

1. **D**o not bend, tug or compress the power cord since this could damage it. Electrical shocks or fire are probably due to a damaged power cord. Only specialized technical personnel are recommended to replace a damaged power cord.
2. **D**o not use extensions or gang modules.
3. **D**o not touch the appliance when barefoot or parts of the body are wet or damp.
4. **D**o not obstruct the air inlet or outlet of the indoor or the outdoor unit. The obstruction of these openings causes a reduction in the operative efficiency of the conditioner with possible consequent failures or damages.
5. **I**n no way alter the characteristics of the appliance.
6. **D**o not install the appliance in environments where the air could contain flammable gas, oil or sulphur or near sources of heat.
7. **T**his appliance is not intended for use by persons (including children) with reduced physical, sensory or mental capabilities, or lack of experience and knowledge, unless they have been given supervision or instruction concerning use of the appliance by a person responsible for their safety.
8. **D**o not climb onto or place any heavy or hot objects on top of the appliance.
9. **D**o not leave windows or doors open for long time when the air conditioner is operating.
10. **D**o not direct the airflow onto plants or animals.
11. **L**ong direct exposure to the flow of cold air of the conditioner could have negative effects on plants and animals.
12. **D**o not put the conditioner in contact with water. The electrical insulation could be damaged and thus cause electrocution.
13. **D**o not climb onto or place any objects on the outdoor unit.
14. **N**ever insert a stick or similar object into the appliance. It could cause injury.
15. **C**hildren should be supervised to ensure that they do not play with the appliance.
16. **T**his unit is equipped with a refrigerant leak detector for safety.
17. **T**his refrigerant sensor is only replaced with a manufacturer approved sensor. If the sensor is replaced only as part of the component assembly, the component should be labeled.
(Some models have refrigerant leak sensors, subject to the actual product received.)
18. **T**he appliance shall be installed according to the manufacturer's instructions, and the ventilation pipe shall not exceed the maximum length and number of turns specified by the manufacturer.
19. **A**ppliances shall be installed according to the instructions. Appliances that can be installed in different locations should be tested in all locations permitted by the manufacturer. The intake or exhaust openings should not be covered and the manufacturer's recommended air filter should be installed according to the instructions.

20. LEAK DETECTION SYSTEM installed. Unit must be powered except for service.

NOTE(WiFi models only)

This device complies with Part 15 of the FCC Rules. Operation is subject to the following two conditions:

1. This device may not cause harmful interference.
2. This device must accept any interference received, including interference that may cause undesired operation.

Instruction for Servicing (R32)

1. Check the information in this manual to find out the dimensions of space needed for proper installation of the device, including the minimum distances allowed compared to adjacent structures.
2. Appliance shall be installed, operated and stored in a room with a floor area larger than 58m².
3. The installation of pipe-work shall be kept to a minimum.
4. The pipe-work shall be protected from physical damage, and shall not be installed in an unventilated space if the space is smaller than 58m².
5. The compliance with national gas regulations shall be observed.
6. The mechanical connections shall be accessible for maintenance purposes.
7. Follow the instructions given in this manual for handling, installing, cleaning, maintaining and disposing of the refrigerant.
8. Make sure ventilation openings clear of obstruction.
9. **Notice:** The servicing shall be performed only as recommended by the manufacturer.
10. **Warning:** The appliance shall be stored in a well-ventilated area where the room size corresponds to the room area as specified for operation.
11. **Warning:** The appliance shall be stored in a room without continuously operating open flames (for example an operating gas appliance) and ignition sources (for example an operating electric heater).
12. The appliance shall be stored so as to prevent mechanical damage from occurring.
13. It is appropriate that anyone who is called upon to work on a refrigerant circuit should hold a valid and up-to-date certificate from an assessment authority accredited by the industry and recognizing their competence to handle refrigerants, in accordance with the assessment specification recognized in the industrial sector concerned. Service operations should only be carried out in accordance with the recommendations of the equipment manufacturer. Maintenance and repair operations that require the assistance of other qualified persons must be conducted under the supervision of the person competent for the use of flammable refrigerants.
14. Every working procedure that affects safety factors shall only be carried out by specialized persons.

15. Warning:

- * Do not use any means to accelerate the defrosting process or clean the frost on your own. Follow the recommended guidelines from the manufacturer.
- * The appliance shall be stored in a room without continuously operating ignition sources (for example: Open flames, an operating gas appliance or an operating electric heater).
- * Do not pierce or burn.
- * Be aware that refrigerants may not contain an odor.

Important Considerations

- 1) The air conditioner must be installed by professional personnel and the Installation manual is used only for the professional installation personnel! The installation specifications should be subject to our after-sale service regulations.
- 2) When filling the combustible refrigerant, any of your rough operations may cause serious injuries to human body and objects.
- 3) A leak test must be done after the installation completed.
- 4) It is a must to do the safety inspection before maintaining or repairing an air conditioner using combustible refrigerant in order to ensure that the fire risk is reduced to minimum.
- 5) It is necessary to operate the machine under a controlled procedure in order to ensure that any risk arising from the combustible gas or vapor during the operation is reduced to minimum.
- 6) Requirements for the total weight of filled refrigerant and the area of a room to be equipped with an air conditioner (are shown as in the following tables).

The maximum charge and the required minimum floor area

$$m_1 = (6 \text{ m}^3) \times \text{LFL}, m_2 = (52 \text{ m}^3) \times \text{LFL}, m_3 = (260 \text{ m}^3) \times \text{LFL}$$

Where LFL is the lower flammable limit in kg/ m³, R32 LFL is 0.306 kg/ m³.

For the appliances with a charge amount $m_1 < M = m_2$:

The maximum charge in a room shall be in accordance with the following:

$$M_{\max} = \text{SF} \times \text{LFL} \times h_0 \times A$$

The required minimum floor area A_{\min} to install an appliance with refrigerant charge $M(\text{kg})$ shall be in accordance with following: $A_{\min} = M / (\text{SF} \times \text{LFL} \times h_0)$

Refrigerant Charge and Room Area Limitations

In UL/CSA 60335-2-40, R32 refrigerant is classified as class A2L, which is mildly flammable.

Therefore, R32 refrigerant is suitable for systems needing additional refrigerant charge and which will limit the area of the rooms being served by the system. Similarly, the total amount of refrigerant in the system shall be less than or equal to the allowable maximum refrigerant charge. The allowable maximum refrigerant charge depends on the area of the rooms being served by the system.

NOTE:

The terms in this section are explained as follows:

Mc: The actual refrigerant charge in the system.

A: The actual room area where the appliance is installed.

Amin: The required minimum room area.

Mmax: The allowable maximum refrigerant charge in a room.

Qmin: The minimum circulation airflow.

Anvmin: The minimum opening area for connected rooms.

TAmin: The total area of the conditioned space (For appliances serving one or more rooms with an air duct system).

TA: The total area of the conditioned space connected by air ducts.

CAUTION:

The space considered shall be any space which contains refrigerant-containing parts or into which refrigerant could be released.

The room area (A) of the smallest, enclosed, occupied space shall be used in the determination of the refrigerant quantity limits.

For determination of room area (A) when used to calculate the refrigerant charge limit, the following shall apply.

The room area (A) shall be defined as the room area enclosed by the projection to the base of the walls, partitions and doors of the space in which the appliance is installed.

Spaces connected by only drop ceilings, ductwork, or similar connections shall not be considered a single space.

Units mounted higher than 70-55/64 inches and spaces divided by partition walls that are no higher than 62-63/64 inches shall be considered a single space.

Rooms on the same floor and connected by an open passageway between the spaces can be considered a single room when determining compliance to Amin, if the passageway complies with all of the following.

- 1) It is a permanent opening.
- 2) It extends to the floor.
- 3) It is intended for people to walk through.

The area of the connected rooms, on the same floor, connected by permanent opening in the walls and/ or doors between occupied spaces, including gaps between the wall and the floor can be considered a single room when determining compliance to Anvmin, provided all of the following conditions are met as fig.2-1.

Low level opening

- 1) The opening shall not be less than Anvmin in Table2-1.
- 2) The area of any openings above 11-13/16 inches from the floor shall not be considered in determining compliance with Anvmin.
- 3) At least 50% of the opening area of Anvmin shall be below 7-7/8 inches from the floor.
- 4) The bottom of the opening is not more than 3-15/16 inches from the floor.
- 5) The opening is a permanent opening that cannot be closed.
- 6) For openings extending to the floor the height shall not be less than 25/32 inches above the surface of the floor covering.

High level opening

- 1) The opening shall not be less than 50% of Anvmin in Table2-1.
- 2) The opening is a permanent opening that cannot be closed.
- 3) The opening shall be at least 59 inches above the floor.
- 4) The height of the opening is not less than 25/32 inches.

NOTE:

The requirement for the second opening can be met by drop ceilings, ventilation ducts, or similar arrangements that provide an airflow path between the connected rooms.

The minimum opening for natural ventilation (Anvmin) in connected rooms is related to the room area (A), the actual refrigerant charge of refrigerant in the system (Mc), and the allowable MAXIMUM REFRIGERANT CHARGE in the system (Mmax), Anvmin can be determined according to Table 2-1.

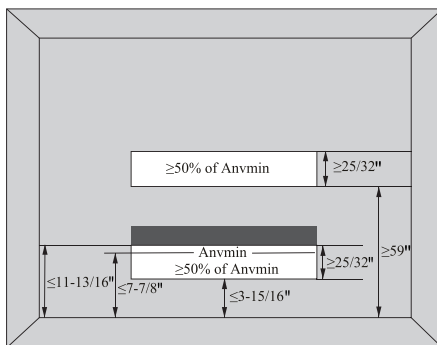

Fig.2-1 Opening Conditions for Connected Rooms

The minimum opening area for connected rooms

Table 2-1

A(ft ²)	Mc(□lbs□oz)		Mmax(□lbs□oz)		Anvmin(ft ²)
	lbs	oz	lbs	oz	
40	7	12	2	12	0.7
50	7	12	3	7	0.6
60	7	12	4	2	0.5
70	7	12	4	13	0.4
80	7	12	5	8	0.3
90	7	12	6	3	0.2
100	7	12	6	14	0.1
110	7	12	7	9	0.1
120	7	12	8	4	0.0
130	7	12	8	15	0.0
140	7	12	9	10	0.0
150	7	12	10	4	0.0
160	7	12	10	10	0.0

Note: Take the Mc=7 lbs 12 oz as an example.

For appliances serving one or more rooms with an air duct system, The room area calculation shall be determined based on the total area of the conditioned space(TA) connected by ducts taking into consideration that the circulating airflow distributed to all the rooms by the appliance integral indoor fan will mix and dilute the leaking refrigerant before entering any room.

The allowed maximum refrigerant charge and required minimum room area

If the fan incorporated to an appliance is continuously operated or operation is initiated by a REFRIGERANT DETECTION SYSTEM with a sufficient CIRCULATION AIRFLOW rate, the allowable maximum refrigerant charge (Mmax) and the required minimum room area(Amin/TAmin) is shown in Table 2-2 and Table 2-3.

The allowable maximum refrigerant charge

Table 2-2

A/TA(ft ²)	Mc(□lbs□oz)		A/TA(ft ²)	Mmax(□lbs□oz)	
	lbs	oz		lbs	oz
40	2	12	160	10	9
50	3	7	170	10	15
60	4	2	180	11	4
70	4	13	190	11	9
80	5	8	200	11	13
90	6	3	210	12	2
100	6	14	220	12	7
110	7	9	230	12	11
120	8	4	240	13	0
130	8	15	250	13	4
140	9	10	260	13	8
150	10	4			

The required minimum room area

Table 2-3

Mc(□lbs□oz)		Amin/Tamin(ft ²)	Mmax(□lbs□oz)		Amin/Tamin(ft ²)
lbs	oz		lbs	oz	
4	0	58.1	11	0	171.3
4	8	65.4	11	8	187.2
5	0	72.6	12	0	203.9
5	8	79.9	12	8	221.2
6	0	87.1	13	0	239.3
6	8	94.4	13	8	258.0
7	0	101.6	14	0	277.5
7	8	108.9	14	8	297.6
8	0	116.2	15	0	318.5
8	8	123.4	15	8	340.1
9	0	130.7	16	0	362.4
9	8	137.9	16	8	385.4
10	0	145.2	17	0	409.1
10	8	156.1	17	8	433.5

The minimum circulation airflow

Table 2-4

Mc(□lbs□oz)		Qmin(CFM)	Mmax(□lbs□oz)		Qmin(CFM)
lbs	oz		lbs	oz	
4	0	105	11	0	289
4	8	118	11	8	302
5	0	131	12	0	315
5	8	145	12	8	328
6	0	158	13	0	341
6	8	171	13	8	354
7	0	184	14	0	367
7	8	197	14	8	380
8	0	210	15	0	393
8	8	223	15	8	406
9	0	236	16	0	419
9	8	249	16	8	433
10	0	262	17	0	446
10	8	275	17	8	459

CAUTION:

The allowable maximum refrigerant charge of the Table 2-2 or the required minimum room area of the Table 2-3 is available only if the following conditions are met:

Minimum velocity of 3.28ft/s, which is calculated as the indoor unit airflow divided by the nominal face area of the outlet. And the grill area shall not be deducted.

Minimum airflow rate must meet the corresponding values in Table 2-4, which is related to the actual

refrigerant charge of the system (Mc).

R32 refrigerant leakage sensor is configured.

If the safety protection function depends on continuous air circulation, the following shall apply: Continuous air circulation is required for proper operation. The unit must remain powered on except during maintenance.

NOTE:

The maximum refrigerant limit described above applies to unventilated areas. If adding additional measures, such as areas with mechanical ventilation or natural ventilation, The maximum refrigerant charge can be increased or the minimum room area can be reduced.

R32 refrigerant leakage sensor is configured for the indoor unit, meets the incorporated circulation airflow requirements, the maximum refrigerant charge or minimum room area can be determined according to Table 2-2 or Table 2-3.

CAUTION:

If the actual room area, air outlet height, and refrigerant charge amount are not reflected in the above table. more severe cases need to be considered according to the data in the table 2-1, 2-2, 2-3, 2-4.



Caution: Risk of fire

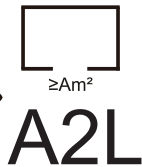

Read operator's manual



Operating instructions



Caution: Risk of fire



Read technical manual

16. Information on servicing:

1) Checks to the area

Prior to beginning work on systems containing flammable refrigerants, safety checks are necessary

to ensure that the risk of ignition is minimized. For repair to the refrigerating system, the following precautions shall be complied with prior to conducting work on the system.

2) Work procedure

Work shall be undertaken under a controlled procedure so as to minimize the risk of a flammable gas or vapor being present while the work is being performed.

3) General work area

All maintenance staff and others working in the local area shall be instructed on the nature of work being carried out. Work in confined spaces shall be avoided. The area around the workspace shall be sectioned off. Ensure that the conditions within the area have been made safe by control of flammable material.

4) Checking for presence of refrigerant

The area shall be checked with an appropriate refrigerant detector prior to and during work, to ensure the technician is aware of potential flammable atmospheres. Ensure that the leak detection equipment being used is suitable for use with flammable refrigerants, i.e. non-sparking, adequately sealed or intrinsically safe.

5) Presence of fire extinguisher

If any hot work is to be conducted on the refrigeration equipment or any associated parts, appropriate fire extinguishing equipment shall be available to hand. Have a dry powder or CO₂ fire extinguisher adjacent to the charging area.

6) No ignition sources

No person carrying out work in relation to a refrigeration system which involves exposing any pipe work shall use any sources of ignition in such a manner that it may lead to the risk of fire or explosion. All possible ignition sources, including cigarette smoking, should be kept sufficiently far away from the site of installation, repairing, removing and disposal, during which refrigerant can possibly be released to the surrounding space. Prior to work taking place, the area around the equipment is to be surveyed to make sure that there are no flammable hazards or ignition risks. "No Smoking" signs shall be displayed.

7) Ventilated area

Ensure that the area is in the open or that it is adequately ventilated before breaking into the system or conducting any work that will produce heat. A degree of ventilation shall continue during the period that the work is carried out. The ventilation should safely disperse any released refrigerant and preferably expel it externally into the atmosphere.

8) Checks to the refrigeration equipment

Where electrical components are being changed, they shall be fit for the purpose and to the correct specification. At all times the manufacturer's maintenance and service guidelines shall be followed.

If in doubt consult the manufacturer's technical department for assistance.

The following checks shall be applied to installation using flammable refrigerant:

- The charge size is in accordance with the room size within which the refrigerant containing parts are installed;
- The ventilation machinery and outlets are operating adequately and are not obstructed;
- If an indirect refrigerating circuit is being used, the secondary circuit shall be checked for the presence of refrigerant;
- Marking to the equipment continues to be visible and legible. Markings and signs that are illegible shall be corrected;
- Refrigeration pipe or components are installed in a position where they are unlikely to be exposed to any substance which may corrode refrigerant containing components, unless the components are constructed of materials which are inherently resistant to being corroded or are suitably protected against being so corroded.

9) Checks to electrical devices

Repair and maintenance to electrical components shall include initial safety checks and component inspection procedures. If a fault exists that could compromise safety, then no electrical supply shall be connected to the circuit until it is satisfactorily dealt with. If the fault cannot be corrected immediately but it is necessary to continue operation, an adequate temporary solution shall be used. This shall be reported to the owner of the equipment so all parties are advised.

Initial safety checks shall include:

- That capacitors are discharged: This shall be done in a safe manner to avoid possibility of sparking;
- That no live electrical components and wiring are exposed while charging, recovering or purging the system;
- That there is continuity of earth bonding.

17. Repairs to sealed components

Sealed electrical components shall be replaced.

18. Repair to intrinsically safe components

Intrinsically safe components must be replaced.

19. Cabling

Check that cabling will not be subject to wear, corrosion, excessive pressure, vibration, sharp edges or any other adverse environmental effects. The check shall also take into account the effects of aging or continual vibration from sources such as compressors or fans.

20. Detection of flammable refrigerants

Under no circumstances shall potential sources of ignition be used in the searching for or detection of refrigerant leaks. A halide torch (or any other detector using a naked flame) shall not be used.

21. Leak detection methods

The following leak detection methods are deemed acceptable for systems containing flammable refrigerants.

Electronic leak detectors shall be used to detect flammable refrigerants, but the sensitivity may not be adequate, or may need re-calibration. (Detection equipment shall be calibrated in a refrigerant-free area.) Ensure that the detector is not a potential source of ignition and is suitable for the refrigerant used. Leak detection equipment shall be set at a percentage of the LFL of the refrigerant and shall be calibrated to the refrigerant employed and the appropriate percentage of gas (25 % maximum) is confirmed. Leak detection fluids are suitable for use with most refrigerants but the use of detergents containing chlorine shall be avoided as the chlorine may react with the refrigerant and corrode the copper pipe-work. If a leak is suspected, all naked flames shall be removed/ extinguished. If a leakage of refrigerant is found which requires brazing, all of the refrigerant shall be recovered from the system, or isolated (by means of shut off valves) in a part of the system remote from the leak. Oxygen free nitrogen (OFN) shall then be purged through the system both before and during the brazing process.

22. Removal and evacuation

When breaking into the refrigerant circuit to make repairs or for any other purpose conventional procedures shall be used. However, it is important that best practice is followed since inflammability is a consideration. The following procedure shall be adhered to:

- Remove refrigerant;
- Purge the circuit with inert gas;
- Evacuate;
- Purge again with inert gas;
- Open the circuit by cutting or brazing.

The refrigerant charge shall be recovered into the correct recovery cylinders. The system shall be flushed with OFN to render the unit safe. This process may need to be repeated several times.

Compressed air or oxygen shall not be used for this task.

Flushing shall be achieved by breaking the vacuum in the system with OFN and continuing to fill until the working pressure is achieved, then venting to atmosphere, and finally pulling down to a vacuum. This process shall be repeated until no refrigerant is within the system. When the final OFN charge is used, the system shall be vented down to atmospheric pressure to enable work to take place. This operation is absolutely vital if brazing operations on the pipe-work are to take place.

Ensure that the outlet for the vacuum pump is not close to any ignition sources and there is ventilation available.

23. Decommissioning

Before carrying out this procedure, it is essential that the technician is completely familiar with the equipment and all its details. It is recommended good practice that all refrigerants are recovered safely.

Prior to the task being carried out, an oil and refrigerant sample shall be taken in case analysis is required prior to re-use of reclaimed refrigerant. It is essential that electrical power is available before the task is commenced.

- 1) Become familiar with the equipment and its operation.
- 2) Isolate system electrically.
- 3) Before attempting the procedure, ensure that:
 - Mechanical handling equipment is available, if required, for handling refrigerant cylinders;
 - All personal protective equipment is available and being used correctly;
 - The recovery process is supervised at all times by a competent person;
 - Recovery equipment and cylinders conform to the appropriate standards.
- 4) Pump down refrigerant system, if possible.
- 5) If a vacuum is not possible, make a manifold so that refrigerant can be removed from various parts of the system.
- 6) Make sure that cylinder is situated on the scales before recovery takes place.
- 7) Start the recovery machine and operate in accordance with manufacturer's instructions.
- 8) Do not overfill cylinders. (No more than 80% volume liquid charge).
- 9) Do not exceed the maximum working pressure of the cylinder, even temporarily.
- 10) When the cylinders have been filled correctly and the process completed, make sure that the cylinders and the equipment are removed from site promptly and all isolation valves on the equipment are closed off.
- 11) Recovered refrigerant shall not be charged into another refrigeration system unless it has been cleaned and checked.

24. Labeling

Equipment shall be labeled stating that it has been de-commissioned and emptied of refrigerant. The label shall be dated and signed. Ensure that there are labels on the equipment stating the equipment contains flammable refrigerant.

25. Recovery

When removing refrigerant from a system, either for servicing or decommissioning, it is recommended good practice that all refrigerants are removed safely.

When transferring refrigerant into cylinders, ensure that only appropriate refrigerant recovery cylinders are employed. Ensure that the correct number of cylinders for holding the total system charge are available. All cylinders to be used are designated for the recovered refrigerant and labeled for that refrigerant(i.e. Special cylinders for the recovery of refrigerant). Cylinders shall be complete with pressure-relief valve and associated shut-off valves in good working order.

Empty recovery cylinders are evacuated and, if possible, cooled before recovery occurs.

The recovery equipment shall be in good working order with a set of instructions concerning the equipment that is at hand and shall be suitable for the recovery of all appropriate refrigerants including, when applicable, flammable refrigerants. In addition, a set of calibrated weighing scales shall be available and in good working order. Hoses shall be complete with leak-free disconnect couplings and in good condition. Before using the recovery machine, check that it is in satisfactory working order, has been properly maintained and that any associated electrical components are sealed to prevent ignition in the event of a refrigerant release. Consult manufacturer if in doubt.

The recovered refrigerant shall be returned to the refrigerant supplier in the correct recovery cylinder, and the relevant waste transfer note arranged. Do not mix refrigerants in recovery units and especially not in cylinders.

If compressors or compressor oils are to be removed, ensure that they have been evacuated to an acceptable level to make certain that flammable refrigerant does not remain within the lubricant.

The evacuation process shall be carried out prior to returning the compressor to the suppliers.

Only electric heating to the compressor body shall be employed to accelerate this process. When oil is drained from a system, it shall be carried out safely.

26. Warning:

- 1) Do not use means to accelerate the defrosting process or to clean, other than those recommended by the manufacturer.
- 1) Ne pas utiliser de produits permettant d'accélérer le dégel ou de produits de nettoyage autres que ceux recommandés par le fabricant.
- 2) The appliance shall be stored in a room without continuously operating ignition sources (for example: Open flames, an operating gas appliance or an operating electric heater).
- 2) L'appareil doit être entreposé dans un endroit sans source d'allumage fonctionnant en continu (par exemple: Flamme nue, appareil au gaz en marche ou radiateur électrique en marche).
- 3) Do not pierce or burn.
- 3) Ne pas percer ni brûler.
- 4) Be aware that refrigerants may not contain an odor.
- 4) Attention: Les frigorigènes peuvent être inodores.

27. Statement

- 1) Please use the flammable gas detector to check before unloading and open the container.
- 2) No fire source and smoking.
- 3) That pipe work shall be protected from physical damage and, in the case of FLAMMABLE REFRIGERANTS, shall not be installed in an unventilated space, if that space is smaller than Amin in Annex GG, except for A2L REFRIGERANTS where the installed pipes comply with UL 60335-2-40 Clause. In case of field charge, the effect on REFRIGERANT CHARGE caused by the different

pipe length has to be quantified.

- 4) That compliance with national gas regulations shall be observed.
- 5) Be shipped with a **FLAMMABLE REFRIGERANT CHARGE**. Joints made in the installation between parts of the **REFRIGERATING SYSTEM**, with at least one part charged, shall be made in accordance with the following.
 - A brazed, welded, or mechanical connection shall be made before opening the valves to permit refrigerant to flow between the **REFRIGERATING SYSTEM** parts. A vacuum valve shall be provided to evacuate the interconnecting pipe or any uncharged **REFRIGERATING SYSTEM** part.
 - Mechanical connectors used indoors shall comply with ISO 14903. When mechanical connectors are reused indoors, sealing parts shall be renewed. When flared joints are reused indoors, the flare part shall be refabricated.
 - Refrigerant tubing shall be protected or enclosed to avoid damage.
 - Flexible refrigerant connectors (such as connecting lines between the indoor and outdoor unit) that may be displaced during **NORMAL OPERATION** shall be protected against mechanical damage. Compliance is checked according to the installation instructions and a trial installation, if necessary. For installations with field applied joints that are exposed in the occupied space, these joints shall be at least one of the following:
 - Mechanical joints in compliance with ISO 14903 or UL 207 (U.S. only);
 - Welded or brazed joints; or
 - Joints in enclosures that vent to the unit or to the outside.
- 6) That pipe work including piping material, pipe routing, and installation shall include protection from physical damage in operation and service, and be in compliance with national and local codes and standards, such as ASHRAE 15, ASHRAE 15.2, IAPMO Uniform Mechanical Code, ICC International Mechanical Code, or CSA B52. All field joints shall be accessible for inspection prior to being covered or enclosed;
- 7) That after completion of field piping for split systems, the field pipe work shall be pressure tested with an inert gas and then vacuum tested prior to refrigerant charging, according to the following requirements;
- 8) The appliance shall be stored so as to prevent mechanical damage from occurring.
- 9) Working personnel for maintenance, service and repair operations. Every working procedure that affects safety means shall only be carried out by competent persons according to Annex HH. Examples for such working procedures are:
 - Breaking into the refrigerating circuit;
 - Opening of sealed components;
 - Opening of ventilated enclosures.

Installation Safety Principles

1. Site Safety



Open flames prohibited

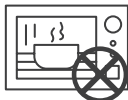

Ventilation necessary

Operation Safety



Mind static electricity



Must wear protective clothing and anti-static gloves



Don't use mobile phone

2. Installation Safety

- Refrigerant Leak Detector
- Appropriate Installation Location

















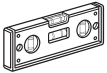

The left picture is the schematic diagram of a refrigerant leak detector.

Please note that:

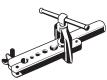
- 1) The installation site should be well-ventilated.
- 2) The sites for installing and maintaining an air conditioner using Refrigerant R32 should be free from open fire or welding, smoking, drying oven or any other heat source higher than 548°C which easily produces open fire.
- 3) When installing an air conditioner, it is necessary to take appropriate anti-static measures such as wear anti-static clothing and/or gloves.
- 4) It is necessary to choose the site convenient for installation or maintenance wherein the air inlets and outlets of the indoor and outdoor units should be not surrounded by obstacles or close to any heat source or combustible and/or explosive environment.
- 5) If the indoor unit suffers refrigerant leak during the installation, it is necessary to immediately turn off the valve of the outdoor unit and all the personnel should go out till the refrigerant leaks completely for 15 minutes. If the product is damaged, It is mandatory to carry such damaged product back to the maintenance station and it is prohibited to weld the refrigerant pipe or conduct other operations on the user's site.
- 6) It is necessary to avoid the places where there are other electrical products, power switch plugs and sockets, kitchen cabinet, bed, sofa and other valuables right under the lines on two sides of the indoor unit.

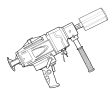
Suggested Tools

Tool	Picture	Tool	Picture	Tool	Picture
Standard Wrench		Pipe Cutter		Vacuum Pump	
Adjustable/Crescent Wrench		Screw Drivers (Phillips & Flat Blade)		Safety Glasses	
Torque Wrench		Manifold and Gauges		Work Gloves	
Hex Keys or Allen Wrenches		Level		Refrigerant Scale	
Drill & Drill Bits		Flaring Tool		Micron Gauge	
Hole Saw		Clamp on Amp Meter		Welding Gun	

The following information is provided for units that employ FLAMMABLE REFRIGERANTS.

- Transport of equipment containing flammable refrigerants

Attention is drawn to the fact that additional transportation regulations may exist with respect to equipment containing flammable gas. The maximum number of pieces of equipment or the configuration of the equipment permitted to be transported together will be determined by the applicable transport regulations.

- Marking of equipment using signs

Signs for similar appliances used in a work area are generally addressed by local regulations and give the minimum requirements for the provision of safety and/or health signs for a work location.

All required signs are to be maintained and employers should ensure that employees receive suitable and sufficient instruction and training on the meaning of appropriate safety signs and the actions that need to be taken in connection with these signs.

The effectiveness of signs should not be diminished by too many signs being placed together.

Any pictograms used should be as simple as possible and contain only essential details.

- Disposal of equipment using flammable refrigerants

See national regulations.

- Storage of equipment/appliances

The storage of the appliance should be in accordance with the applicable regulations or instructions, whichever is more stringent.

- Storage of packed (unsold) equipment

Storage package protection should be constructed in such a way that mechanical damage to the equipment inside the package will not cause a leak of the REFRIGERANT CHARGE.

The maximum number of pieces of equipment permitted to be stored together will be determined by local regulations.

Operating condition	
Inverter air conditioner:	
HEATING	Room temperature 0°C~30°C (32°F~86°F)
	Outdoor temperature -20°C~27°C (-4°F~80°F)
COOLING/ DRY	Room temperature 17°C~32°C (63°F~90°F)
	Outdoor temperature T1 climate: -15°C~52°C (5°F~125°F)

With the power supply connected, restart the air conditioner after shutdown, or switch it to other mode during operation, and the air conditioner protection device will start. The compressor will resume operation after 3 minutes.

Noise pollution
<ul style="list-style-type: none"> Install the air conditioner in a place that can bear its weight in order to operate more quietly. Install the outdoor unit in a place where the air discharged and the operation noise do not annoy your neighbors. Do not place any obstacles in front of the outlet of the outdoor unit for fear it affects operation and increases the noise level.

Features of Protector
<p>1. The protective device will trip at following cases.</p> <ul style="list-style-type: none"> Stop the appliance and restart it at once or change other modes during operation, you have to wait 3 minutes before restarting. After switching on the power circuit breaker and then turn on the air conditioner at once, you have to wait about 20 seconds. <p>2. In case all operations have stopped, you need.</p> <ul style="list-style-type: none"> Press "ON/OFF" button again to restart it. Set TIMER once again if it has been canceled.

Inspection
<p>After a long time of operation, the air conditioner should be inspected for the following items.</p> <ul style="list-style-type: none"> Abnormal heating of the power supply cord or even a burnt smell. Abnormal operating noise or vibration. Water leakage from indoor unit. Metal cabinet electrified. Stop using the air conditioner if above problem happened. It is advisable that the air conditioner should be given a detailed check-up after using for five years even if none of the above happen.

Features of HEATING mode
<p>Preheat</p> <p>2-5 minutes are necessary to preheat the indoor heat exchanger at the beginning of "HEATING" operation, lest cold air be discharged.</p> <p>Defrost</p> <p>In "HEATING" operation the appliance will defrost automatically. This procedure lasts 2~10 minutes, then returns to "HEATING" mode automatically. During defrosting, indoor fan stop running and return to heating mode operation automatically when defrosting has finished.</p>

Unit Location Considerations

Inspect Units

Units are packaged for shipment to avoid damage during normal transit and handling. It is the receiving party's responsibility to inspect the equipment upon arrival. Any obvious damage to the carton box should be reported on the bill of lading and a claim should be filed with the transportation company, and the factory should be noticed.

All units should be stored in the factory shipping carton with internal packaging in a dry place until installation. Carefully remove the packaging and inspect for hidden damage. Any hidden damage should be recorded and the factory should be notified. The gauge port can be used to check the refrigerant charge has been retained during shipment.

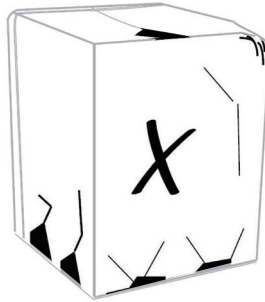

Unit Dimensions

Two models sharing the same chassis are suitable for most residential air conditioner and heat pump applications. When mounting the condensing unit on a roof or pad, be sure its dimension no less than 29" x 29".

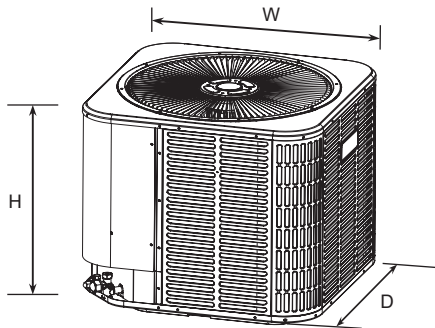

Condensing unit dimensions

Model	H×W×D (Inches)
24K	24-15/16×29-1/8×29-1/8
36K	24-15/16×29-1/8×29-1/8
48K	33-3/16×29-1/8×29-1/8
60K	33-3/16×29-1/8×29-1/8

Location Restrictions

Exposure to a corrosive environment may shorten the life of the equipment, corrode metal parts, and/or negatively affect unit performance. Corrosive elements include, but not limited to: sodium chloride, sodium hydroxide, sodium sulfate, and other compounds commonly found in ocean water, sulfur, chlorine, fluorine, fertilizers, and various chemical contaminants from industry/manufacturing plants. If installed in areas which may be exposed to corrosive environments, special attention should be given to the equipment placement and maintenance.

- Lawn sprinklers/waste water should not spray directly on the unit cabinet for prolonged periods.
- In coastal areas: locate the unit on the side of the building away from the waterfront.

Installation Clearance Requirement

Ensure the top discharge area is unrestricted for at least 60 inches above the unit.

Do not locate condensing unit near bedrooms because normal operational sounds may be annoying.

Position unit to allow adequate space for unobstructed airflow, wiring, refrigerant lines, and serviceability.

Allow a minimum of 12 in. clearance on one side of access panel to a wall and a minimum of 24 in. on the adjacent side of access panel. Maintain a distance of 24 in. between units.

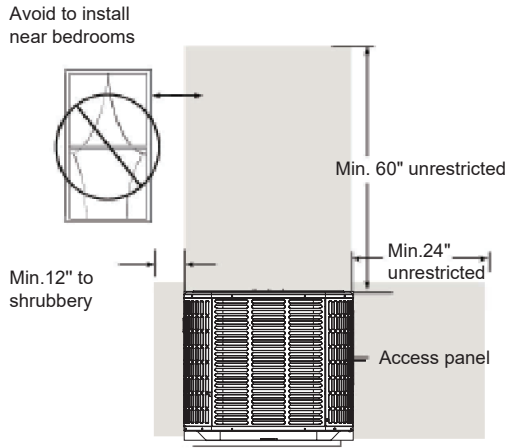

Position unit as water, snow, or ice from roof or overhang cannot fall directly on unit.

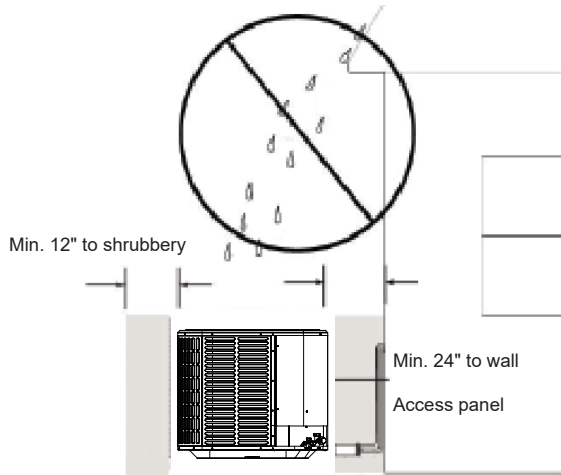

Cold Climate Considerations

Precautions must be taken for units being installed in areas where snow accumulation and prolonged below-freezing temperatures occur.

Elevate unit per local climate and code requirements.

This additional height will allow drainage of snow and ice melted during defrost cycle to flow out smoothly prior to its refreezing.

A snow drift barrier should be installed around the unit to prevent a build-up of snow on the unit sides.

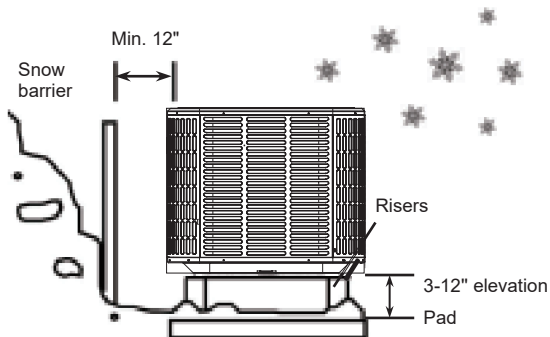

Position The Unit

When mounting the unit on a roof, be sure the roof will support the unit's weight obtained from nameplate.

Properly selected isolation is recommended to prevent sound or vibration transmission to the building structure.

Refrigerant Line Consideration

Refrigerant Line Limits

Use only the line sizes indicated in below table and determine required line length. If the suction line sets are greater than 50 feet, do not use a larger suction line than recommended.

Line sizes and maximum length

Capacity Model	Liquid Line	Suction Line	Minimum Piping Length	Maximum line length	Maximum Elevation Difference(ft)
	Dimensions in inches				
24K	3/8 Std.	3/4 Std.	15	98	49
36K	3/8 Std.	3/4 Std.	15	98	49
48K	3/8 Std.	7/8 Std.	15	164	82
60K	3/8 Std.	7/8 Std.	15	164	82

Std.: Standard line size.

- Maximum line length = ___ feet.

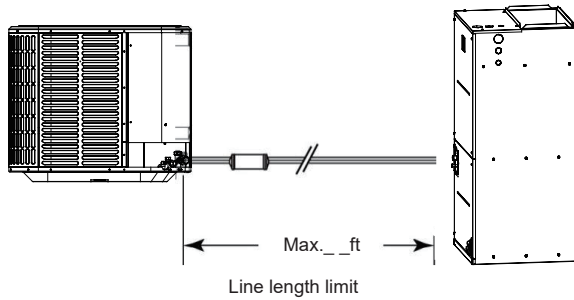

- Maximum elevation difference = ___ feet.

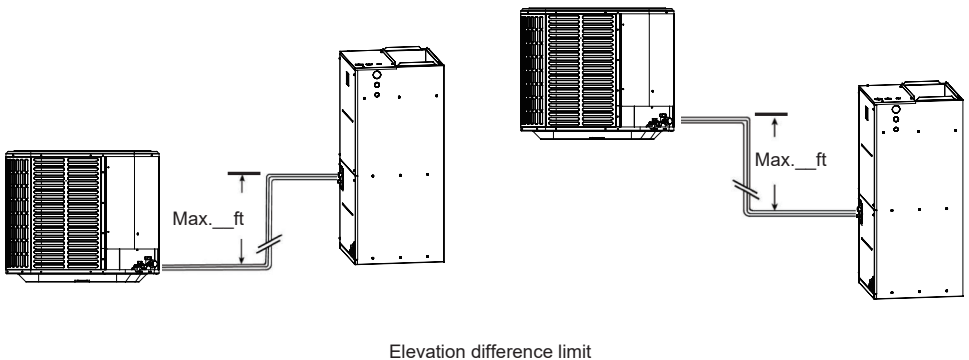

Refrigerant charge label

Please fill in with indelible ink.

- ① The factory refrigerant charge of the product
- ② The additional refrigerant amount charged in the field and refer to the step 4 on section Indoor Unit Installation.
- ① + ② the total refrigerant charge on the refrigerant charge label supplied with the product.

Affix the refrigerant charge label near the manufacturer's label after filling it out.

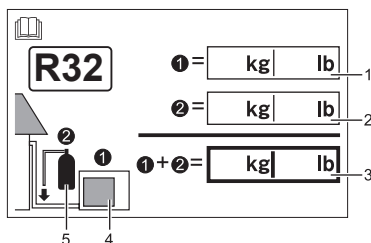

1. Factory refrigerant charge of the product: see unit manufacturer's label.
2. Additional refrigerant amount charged in the field.
3. Total refrigerant charge.
4. Outdoor unit.
5. Refrigerant cylinder and manifold for charging.

Pipe Length and Additional Refrigerant

Model	24K	36K	48K	60K
Length of pipe with standard charge (ft)	25	25	25	25
Refrigerant capacity of standard charge (lbs)	3.97	5.51	7.72	7.72
The longest pipe length (ft)	98	98	164	164
Additional refrigerant charge (lbs/ft)	0.0167	0.0167	0.0167	0.0167
Max. diff. in level between indoor and outdoor unit (ft)	49	49	82	82

For example, for a 36K model, when the pipe is 100ft, the additional refrigerant charging is $(100-25) \times 0.0167 = 1.25$ lbs, and the refrigerant capacity of the whole model is $5.51 + 1.25 = 6.77$ lbs.

Total Refrigerant Capacity (lb)

Model	Category	LFL (lbs/ft ³)	h0 (ft)	Pipe Length (ft)				
				25	49	66	98	164
24K	R32	0.0191	7.2	3.97	4.38	4.66	5.2	/
36K				5.51	5.92	6.2	6.74	/
48K				7.72	8.13	8.41	8.95	10.06
60K				7.72	8.13	8.41	8.95	10.06

Minimum Room Area (ft²)

Model	Category	LFL (lbs/ft ³)	h0 (ft)	Pipe Length (ft)				
				25	49	66	98	164
24K	R32	0.0191	7.2	57.7	63.6	67.7	75.5	/
36K				80	86	90	97.9	/
48K				112.1	118	122.1	129.9	146
60K				115.9	122	126.2	134.3	155.7

Refrigerant Line Insulation

The suction line must always be insulated.

DO NOT allow the suction line and liquid line to come in direct(metal to metal)contact.

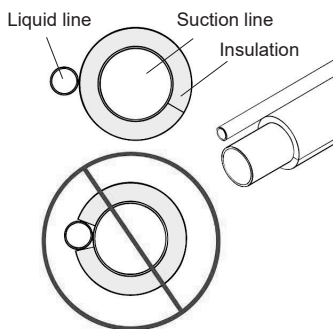

Reuse Existing Refrigerant Lines

⚠ CAUTION

If using existing refrigerant lines, make sure that all joints are brazed, not soldered.

For retrofit applications where the existing refrigerant lines will be used, the following precautions should be taken:

- Ensure that the refrigerant lines are the correct size according to Table 4-1. It's not recommended to use suction line bigger than standard size, in which will result poor oil return for inverter compressor.

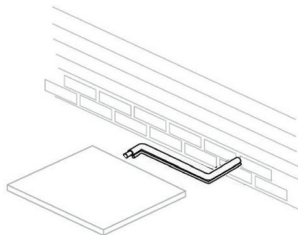

IMPORTANT:

The manufacturer recommends installing only approved matched indoor and outdoor systems. All of the manufacturer's split systems are AHRI rated with EEV indoor units. Some of the benefits of installing approved matched indoor and outdoor split systems are maximum efficiency, optimum performance and the best overall system reliability.

Refrigerant Line Routing

Comply with National, State, and Local Codes when isolating line sets from joists, rafters, walls, or other structural elements. Take precautions to prevent noise within the building structure due to vibration transmission from the refrigerant lines. For Example:

- Use isolation type hangers when the refrigerant lines have to be fastened to floor joists or other framing.
- Isolation hangers should also be used when refrigerant lines traverse stud spaces or enclosed ceilings.
- Where the refrigerant lines pass through a wall or sill, it should be insulated and isolated.
- Isolate the lines from all ductwork.
- Minimize the number of 90° turns.

Isolation from Joist/Rafter

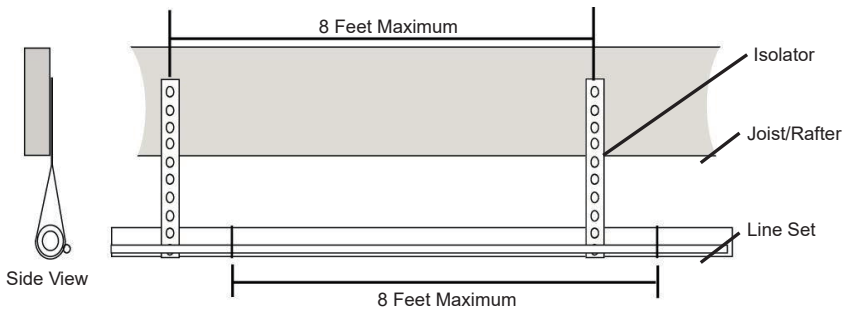

Secure suction line from joists using isolators every 8 ft. Secure liquid line directly to insulated suction line using tape, wire, or other appropriate method every 8 ft.

Isolation in wall spaces

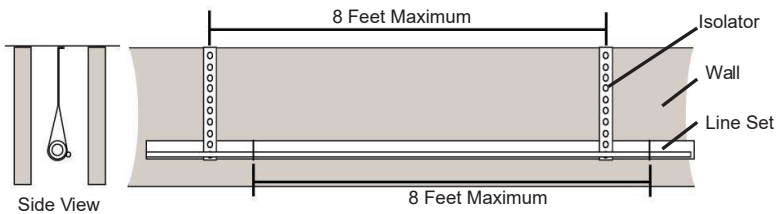

Secure suction line using isolators every 8 ft. Secure liquid line directly to insulated suction line using tape, wire, or other appropriate method every 8 ft.

Isolation through wall

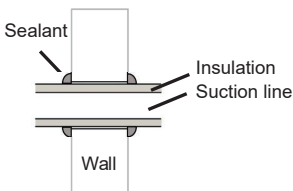

DO NOT hang line sets from ductwork

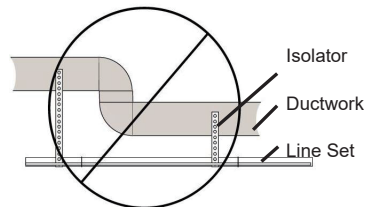

Refrigerant Line Brazing

⚠ CAUTION

- Do not install the connecting pipe until both indoor and outdoor units have been installed. Insulate both the gas and liquid piping to prevent water leakage.
- Be extra careful not to damage, dent, or deform the pipe while cutting. This will drastically reduce the heating efficiency of the unit.

Brazing

Remove the dryer filter and connecting pipe from the outdoor unit, and weld them to the refrigerant pipe as shown in the diagram below.

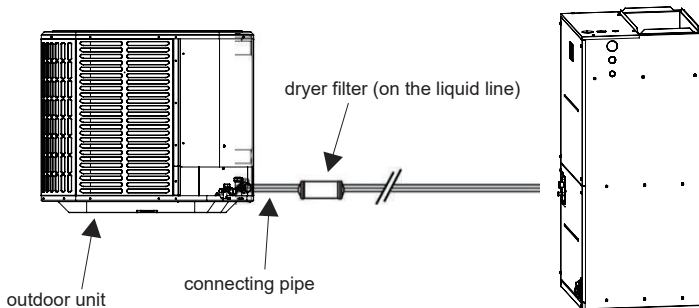

Cut Pipes

When preparing refrigerant pipes, take extra care to cut and flare them properly. This will ensure efficient operation and minimize the need for future maintenance.

1. Use the piping kit accessory or the pipes purchased locally.
2. Measure the distance between the indoor and the outdoor unit.
3. Cut the pipes a little longer than measured distance.

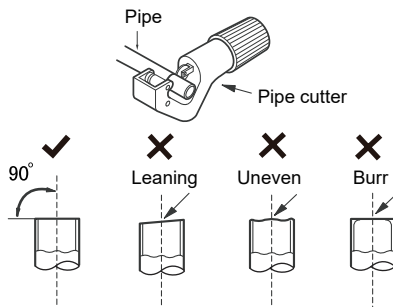

Remove Burrs

Burrs can affect the air-tight seal of refrigerant piping connection. They must be completely removed.

1. Completely remove all burrs from the cut cross section of pipe/tube.
2. Put the end of the copper tube/pipe in a downward direction as you remove burrs in order to avoid dropping burrs into the tubing.

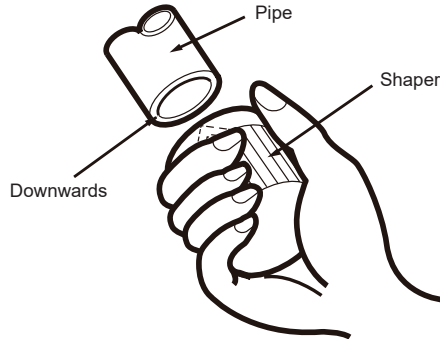

Check

1. Compare the flared work with figure below.
2. If flare is noted to be defective, cut off the flared section and do flaring work again.

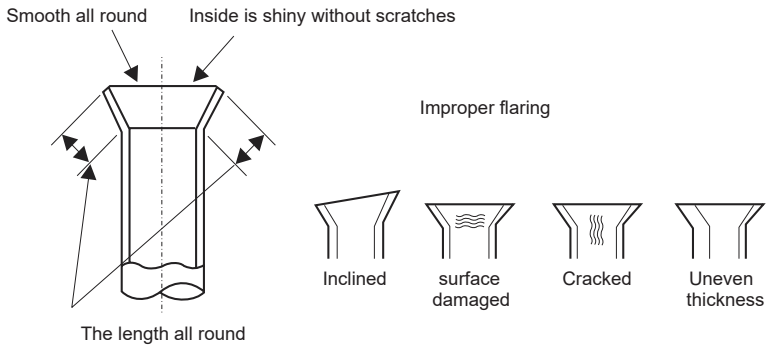

NOTE: Connect the copper pipes to the indoor unit first, then connect it to the outdoor unit.

Flaring Work

Carry out flaring work using flaring tool as shown below.

Outside diameter	A
Inch	Inch
3/8"	0.03"~0.04"
3/4"	0.02"~0.03"
7/8"	0.02"~0.03"

Firmly hold copper pipe in a die in the dimension shown in the table above.

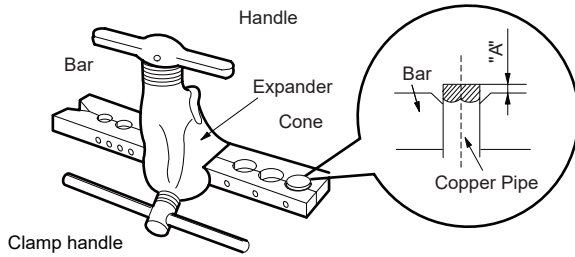

Pipe Connection

You should first connect the low-pressure pipe, then the high-pressure pipe.

1. Align the center of the two pipes that you will connect.
2. Tighten the flare nut as tightly as possible by hand.
3. Using a wrench, grip the nut on the unit tubing.

NOTE: Use two wrenches to connect the pipe with indoor/outdoor pipes to avoid the copper pipe cracking.

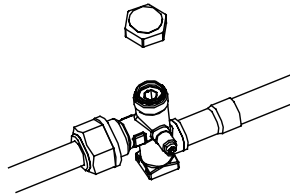

4. While firmly gripping the nut, use a torque wrench to tighten the flare nut according to the torque values.

Connecting Pipe Size	Torque Values (lb ^f ·in)
3/8"	327-372
3/4"	620-664
7/8"	690-735

5. Insert the connecting pipe of the indoor unit into the reamer transfer nozzle flaring of the outdoor unit, and braze the connecting port.

CAUTION

- Ensure to wrap insulation around the piping. Direct contact with the bare piping may result in burns or frostbite.
 - Make sure the pipe is properly connected. Over tightening may damage the bell mouth and under tightening may lead to leakage.
6. Insulate all the piping, including the gas valve of the outdoor unit.

CAUTION

- Check to make sure there is no refrigerant leak after completing the installation work. If there is a refrigerant leak, ventilate the area immediately and evacuate the system (refer to the Air Evacuation section of this manual).

System Leak Check

Leak check is required for the brazed line connections.

1. Pressurize the brazed refrigerant lines and indoor coil to at least 150 PSIG using dry nitrogen.
2. Check for leaks by using a soapy solution or bubbles at each brazed location.

150PSIG

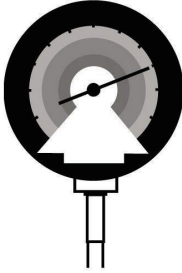

Charge dry nitrogen to the system

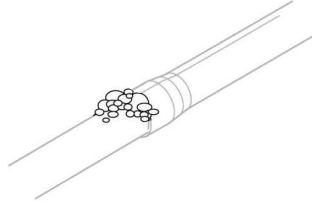

Leak check

Evacuation

Do not open the service valves until the leak check and evacuation are complete.

1. Evacuate until the micron gauge reads no higher than 350 microns, then close the valve to the vacuum pump.
2. Evacuation is complete if the micron gauge does not rise above 500 microns in one minute.

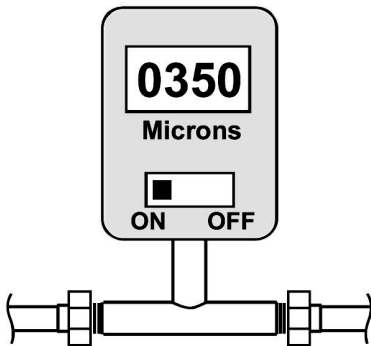

Evacuate the refrigerant system



Service Valves

Leak check and evacuation must be completed before opening the service valves.

The gas service valve must be opened BEFORE opening the Liquid Service Valve!

1. Remove service valve cap.
 2. Fully insert hex wrench into the stem and counterclockwise until valve stem just touches the rolled edge (approximately five turns).
 3. Replace and tighten the valve stem cap to prevent leaks. Additional 1/6 turn may be required.
- Repeat 1 to 3 for Liquid Service Valve.

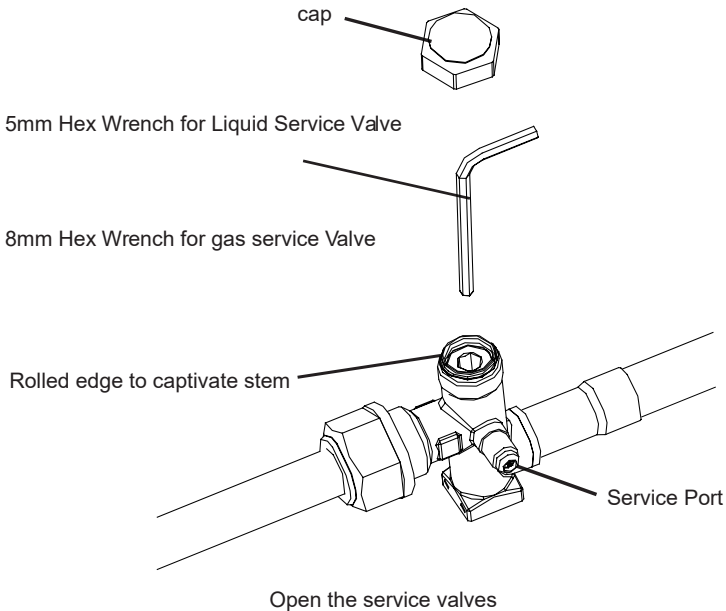

WARNING

Extreme caution should be exercised when opening the Liquid Service Valve. Turn counterclockwise until the valve stem just touches the rolled edge. No torque is required.

Failure to follow this will result in abrupt release of system charge and may lead to personal injury and /or property damage.

Electrical-Low Voltage

Low Voltage Wire Requirement

Define the maximum length of low voltage wiring from condensing unit to indoor unit and thermostat. Field installed electrical conduit is required at the low voltage wire entry point. Animals like frogs, snakes, spiders and others may climb into the control box resulting in the PCB damage. Manufacturer reserves the rights to reject warranty claim on PCB if not compliant.

Low voltage control wiring requirement

Wire Size	Max. Wire Length
18 AWG	164ft

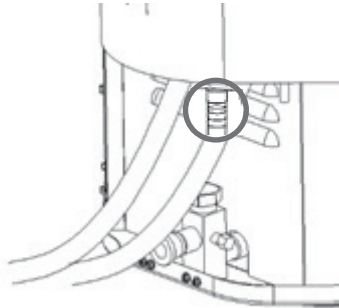

Sealing requirement

Low Voltage Hook-up Diagrams

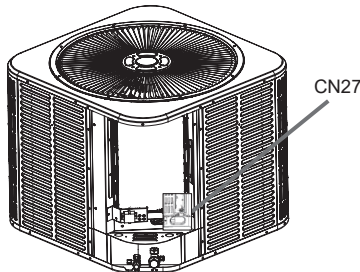
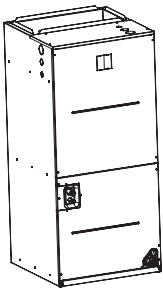

Thermostat wiring harness

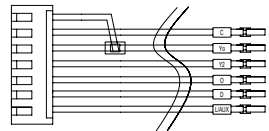

Low voltage control wiring connection

Class 2 low voltage control wiring should not be run in conduit with main power wiring and must be separated from power wiring, unless class 1 wire of proper voltage rating is used.

- Low voltage control wiring should be color-coded 18 AWG.
- Refer to wiring diagrams attached to indoor and outdoor sections to be connected.
- Make sure separation of control wiring and power wiring has been maintained.

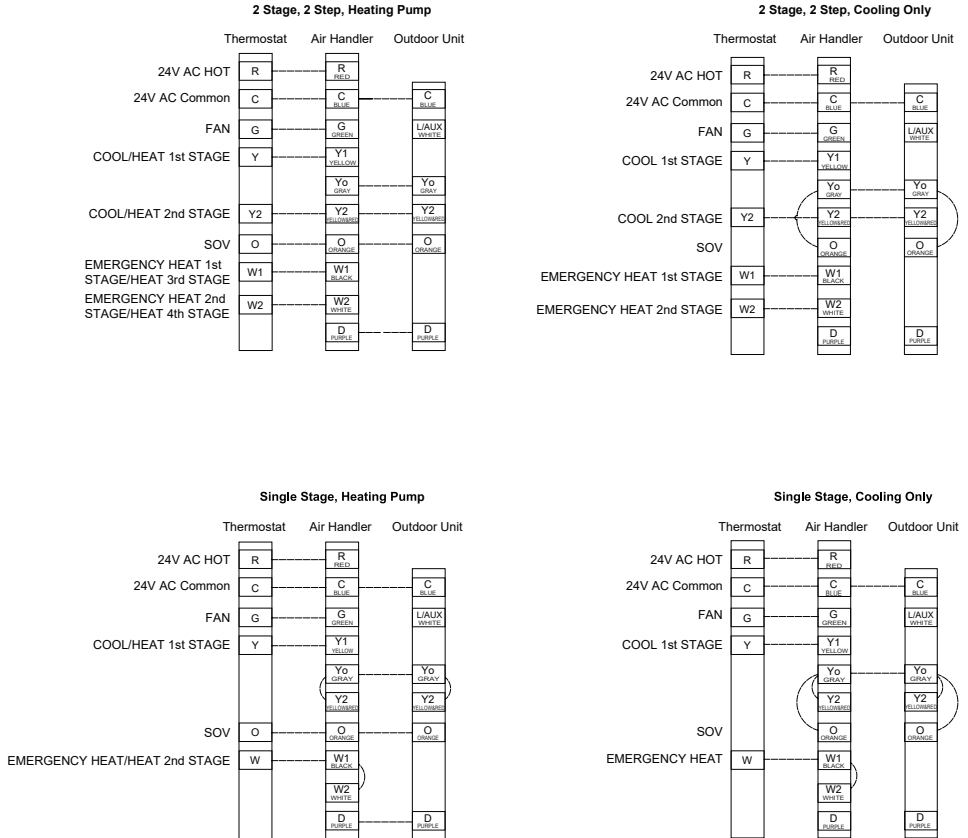

Schematic diagram for control wiring connection

Electrical-High Voltage

High Voltage Power Supply

WARNING

During installation, testing, servicing, and troubleshooting of this product, it may be necessary to work with live electrical components.

Failure to follow all electrical safety precautions when exposed to live electrical components could result in death or serious injury.

The high voltage power supply must agree with the equipment nameplate. Power wiring must comply with National, State and Local codes.

Follow instructions on unit wiring diagram located on the inside of the control box cover.

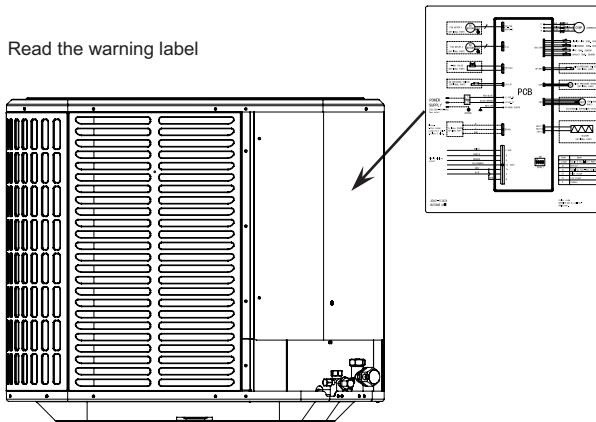

Power Supply			
Model	Voltage	MCA	Breaker
24K	280/230V-1Ph-60Hz	16A	25A
36K		24A	40A
48K		35A	60A
60K		35A	60A

High Voltage Disconnect Switch

Install a separated disconnect switch at the condensing unit. Field provided flexible electrical conduit must be used for high voltage wiring.

In order to get full warranty coverage on the compressor, it's mandatory to install a surge protector to prevent the unit from damaging caused by abnormal electrical spikes.

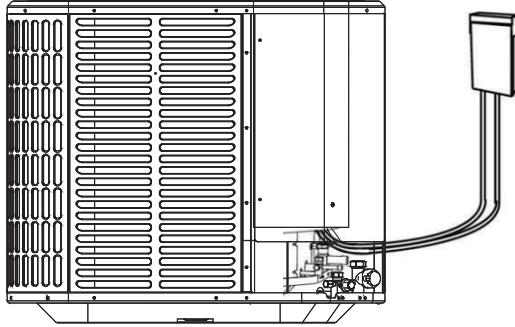

Install an independent switch

High Voltage Ground

Ground the condensing unit according to National, State, and Local code requirements.

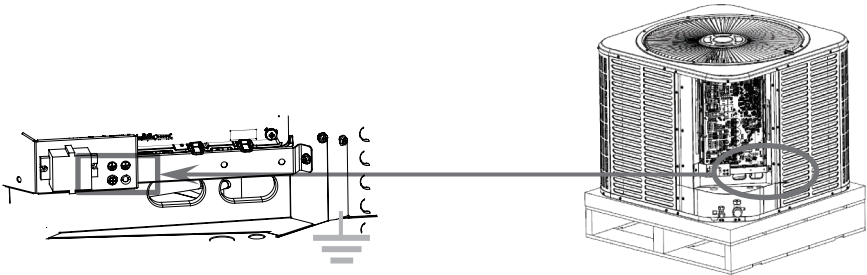

Unit grounding

Start-Up

1. Set the thermostat to OFF.
2. Turn on disconnect switch to apply power to the indoor and outdoor units.
3. Wait an hour before starting the unit if the outdoor ambient temperature < 59°F.
4. Set the thermostat to ON.

ⓘ Attempt to use the air conditioner under the temperature beyond the specified range may cause the air conditioner protection device to start and the air conditioner may fail to operate. Therefore, try to use the air conditioner in the following temperature conditions.

Fixed air conditioner:

MODE Temperature	Heating	Cooling	Dry
Room temperature	0°C~30°C (32°F~86°F)	17°C~32°C (63°F~90°F)	
Outdoor temperature	-20°C~27°C (-4°F~80°F)	-15°C~52°C (5°F~125°F)	

With the power supply connected, restart the air conditioner after shutdown, or switch it to other mode during operation, and the air conditioner protection device will start. The compressor will resume operation after 3 minutes.

ⓘ Characteristics of heating operation (applicable to Heat pump models)

Preheating:

When the heating function is enabled, the indoor unit will take 2~5 minutes for preheating, after that the air conditioner will start heating and blows warm air.

Defrosting:

During heating, when the outdoor unit frosted, the air conditioner will enable the automatic defrosting function to improve the heating effect. During defrosting, the indoor and outdoor fans stop running. The air conditioner will resume heating automatically after defrosting finishes.

System Operation

Default Display

LED on main control board can display the operating status of outdoor unit (ODU).

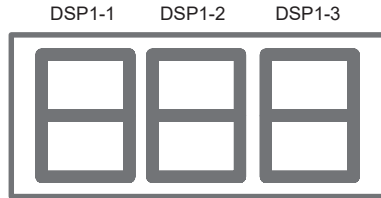

DSP1-1 DSP1-2 Normally blank, but it displays codes accordingly if there is damaged sensor and command response.

See fault code Table 1 for details.

DSP1-3: It displays outdoor unit's operation mode.

code	content	code	content
E0	Indoor and outdoor communication failure	P8	Outdoor temperature too high or too low protection
E1	Indoor environment temperature sensor failure	P9	Compressor drive protection (load abnormality)
E2	Indoor coil temperature sensor failure	PA	Top outlet wind plate communication fault/mode conflict
E3	Outdoor coil temperature sensor failure	F0	Red exterior motion sensor failure
E4	System abnormalities (low refrigerant)	F1	Electricity module failure
E5	Model configuration errors	F2	Exhaust temperature sensor bag failure protection
E6	Indoor PG/DC fan failure	F3	Outer pipe temperature sensor bag failure protection
E7	Outdoor environment temperature sensor failure	F4	Refrigerant circuit abnormal protection
E8	Outdoor exhaust temperature sensor failure	F5	PFC protection
E9	Outdoor IPM module failure/compressor drive failure	F6	Compressor missing/reverse phase protection
EA	Outdoor current sensor failure	F7	Module temperature protection
Eb	Main control board and display screen communication failure	F8	Four-way valve reversing abnormal protection
EC	Outdoor module communication failure	F9	Module temperature sensing circuit failure
EE	Outdoor EEPROM failure	FA	Compressor phase current detection failure

EF	Outdoor DC fan failure	Fb	Refrigeration and heating overload protection
EH	Outdoor air intake sensor failure	FC	Reduced frequency power overload protection
EP	Outdoor compressor shell top failure	FE	Reduced/frequency module current (compressor phase current) protection
EU	Outdoor voltage sensor failure	FF	Reduced/frequency module temperature protection
Ej	Outdoor middle coil temperature sensor failure	FH	Reduced/frequency drive protection
En	Outdoor air pipe temperature sensor failure	FP	Condensation protection
Ey	Outdoor liquid pipe temperature sensor failure	FU	Frost protection
P0	IPM module protection	Fj	Reduced/frequency exhaust protection
P1	Over and under voltage protection	Fn	Reduced/frequency external machine AC current protection
P2	Overcurrent protection	Fy	Reduced/frequency lack of refrigerant protection
P3	Other protections	H1	High pressure switch failure
P4	Outdoor exhaust temperature too high protection	H2	Low pressure switch failure
P5	Refrigeration anti-freezing protection	H3	High pressure sensor failure
P6	Refrigeration anti-overheating protection	H4	Low pressure sensor failure
P7	Heating anti-overheating protection	Hd	Indoor refrigerant leakage protection

DSP1-3 It displays outdoor unit's operation mode.

DSP1-3 code	description
0	Standby
1	Ready
2	Cooling
3	Heating
4	Oil return operation
5	Defrosting operation
6	Forced defrosting
7	Forced cooling operation
8	Forced heating operation
A	Fault
H	Dehumidification mode operation

Field Setting

Setting by dip switches



Note: The DIP switch is checked only once when the main control is powered on. After the DIP switch is powered on, it is not checked again.

SW1 Dip Switch		Description	
NO.	Setting item	Status	Content
SW1-1	Single cooling/heat pump	ON	AC outdoor unit
		digit	HP outdoor unit
SW1-2	Operating capacity	ON	Lower capacity
		digit	Normal capacity
SW1-3 SW1-4	Control mode	ON	485 communication
		digit	24V ON/OFF control

Major Components Function

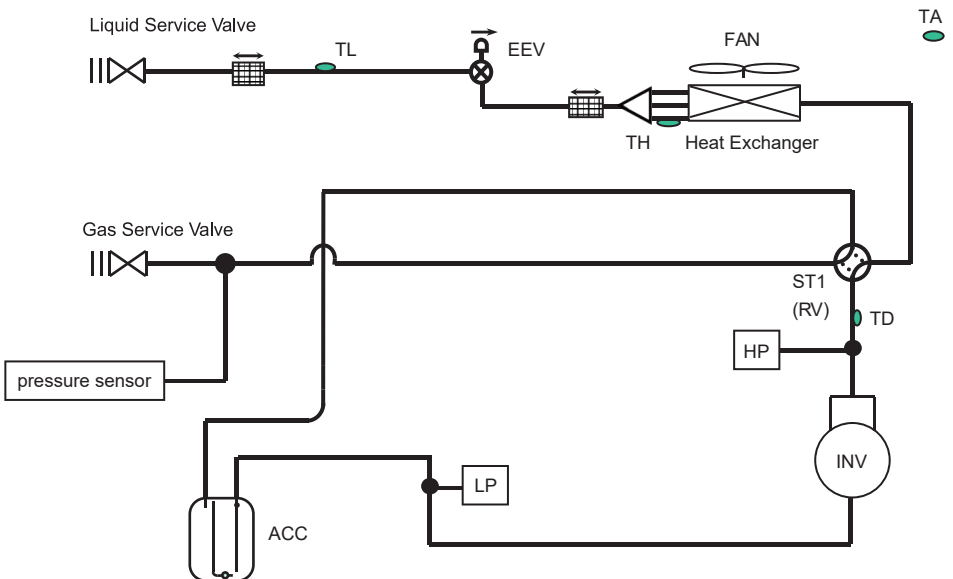

Name	Symbol	Function
Inverter compressor	INV	Adjusts refrigerant flow rate by changing the speed (RPS) based only objective pressure.
DC motor	FAN	Outputs heat exchanger capacity by adjusting the motor rotational speed based on operating pressure.
Electronic expansion valve	EEV	1) Fully open in cooling mode and defrost operation. 2) Control compressor discharge superheat in heating mode.
Reversing valve	ST1 (RV)	Switches the operation mode between heating and cooling (including defrost control).
Temperature sensor	TH	Uses to control defrost during heating operation.
	TA	Uses to detect outdoor air temperature and control fan speed.
	TL	Uses to detect liquid line temperature and calculate sub-cooling (SC).
	TD	Uses to detect compressor discharge temperature and calculate discharge: superheat (DSH).
	TF	Uses to detect heatsink temperature of inverter module.
High pressure switch	HP	Uses to detect high pressure.
Low pressure switch	LP	Uses to detect low pressure.
Accumulator	ACC	To prevent the compressor from ingesting liquid refrigerant.

Troubleshooting

CAUTION

If one of the following conditions occurs, switch off the power supply immediately and contact your dealer for further assistance:

- The operation light continues to flash rapidly after the unit has been restarted.
- The unit continually trips fuses or circuit breakers.
- A foreign object or water enters the air conditioner.
- The indoor unit leaks.
- Other abnormal situations.

Common Problems

The following symptoms are not a malfunction and in most situations will not require repairs.

Problem	Possible Cause
Abnormal noises of outdoor unit	The unit will make different sounds based on its current operating mode.
Both the indoor and outdoor units make noises	The air conditioner may hum during operation. This is a normal phenomenon, which is caused by refrigerant gas flowing through the indoor and outdoor units.
	When the air conditioner is turned on, and just stopped or defrosted, a hiss may be heard. This noise is normal and is caused by refrigerant gas stopping or turning.
Unit does not turn on when pressing ON/ OFF button	The unit has a 3-minute protection feature that prevents the unit from overloading. The unit cannot be restarted within three minutes of being turned off.
	Cooling and Heating Models: If the Operation light and PRE-DEF (Pre-heating / Defrost) indicators are lit up, the outdoor temperature is too cold and the unit's anti-cold wind is activated in order to defrost the unit.
The unit changes from COOL mode to FAN mode	The unit changes its setting to prevent frost from forming on the unit. Once the temperature increases, the unit will start operating again.
	The set temperature has been reached, at which point the unit turns off the compressor. The unit will resume operating when the temperature fluctuates again.
Both the indoor and outdoor units emit white mist	When the unit restarts in HEAT mode after defrosting, white mist may be emitted due to moisture generated from the defrosting process.
Dust is emitted from either the indoor or outdoor unit	The unit may accumulate dust during extended periods of nonuse, which will be emitted when the unit is turned on. This can be mitigated by covering the unit during long periods of inactivity.
The unit emits a bad odor	The unit may absorb odors from the environment (such as furniture, cooking, cigarettes, etc.) which will be emitted during operations.
	The unit filters have become moldy and should be cleaned.
The fan of the outdoor unit does not operate	During operation, the fan speed is controlled to optimize product operation.

Troubleshooting Advice

When troubles occur, please check the following points before contacting a repair company.

Problem	Possible Cause	Solution
The unit is not working	Power failure	Wait for the power to be restored
	The power switch is off	Turn on the power
	The fuse is burned out	Replace the fuse
	The unit's 3-minute protection has been activated	Wait three minutes after restarting the unit
Poor cooling performance	Temperature setting may be higher than the ambient room temperature	Lower the temperature setting
	The heat exchanger on the indoor or outdoor unit is dirty	Clean the affected heat exchanger
	The air filter is dirty	Remove the filter and clean it according to instructions
	The air inlet or outlet of either unit is blocked	Turn the unit off, remove the obstruction and turn it back on
	Doors and windows are open	Make sure that all doors and windows are closed while operating the unit
	Excessive heat is generated by sunlight	Close windows and curtains during periods of high heat or bright sunshine
	Low refrigerant due to leak or long-term use	Check for leaks, re-seal if necessary and top off refrigerant
The unit starts and stops frequently	There's too much or too little refrigerant in the system	Check for leaks and recharge the system with refrigerant
	There is air, incompressible gas or foreign material in the refrigeration system.	Evacuate and recharge the system with refrigerant
	System circuit is blocked	Determine which circuit is blocked and replace the malfunctioning piece of equipment
	The compressor is broken	Replace the compressor
	The voltage is too high or too low	Install a voltage stabilizer to regulate the voltage
Poor heating performance	The outdoor temperature is lower than 44.5°F	Check for leaks and recharge the system with refrigerant
	Cold air is entering through doors and windows	Make sure that all doors and windows are closed during use
	Low refrigerant due to leak or long-term use	Check for leaks, re-seal if necessary and top off refrigerant

Wiring Diagram

Field wiring must comply with the National Electric Code (C.E.C. in Canada) and any applicable local ordinance.

WARNING

Disconnect all power to unit before installing or servicing. More than one disconnect switch may be required to de-energize the equipment. Hazardous voltage can cause severe personal injury or death.

Wiring material ampacities	AWG
4	22
7	20
10	18
13	16
18	14
25	12
30	10
40	8
55	6
70	4

The ampacities shown apply to appliance wiring materials with insulation rated not less than 90°C (194°F).

Supply circuit power wiring must be 167°F minimum copper conductors only.

It is important that proper electrical power is available for connection to the unit model being installed. Refer to the unit nameplate, wiring diagram and electrical data in the installation instructions.

- If required, install a branch circuit disconnect of adequate size, located within sight of, and readily accessible to the unit.
- When the electric heat is installed, units may be equipped with one or two 30–60 amp circuit breakers. These breakers protect the internal wiring in the event of a short circuit and serve as a disconnect. Circuit breakers installed within the unit do not provide over-current protection of the supply wiring and therefore may be sized larger than the branch circuit protection.
- Supply circuit power wiring must be 167°F minimum copper conductors only. Refer to electrical data in this section for ampacity, wire size and circuit protector requirements. Supply circuit protective devices may be either fuses or "HACR" type circuit breakers.

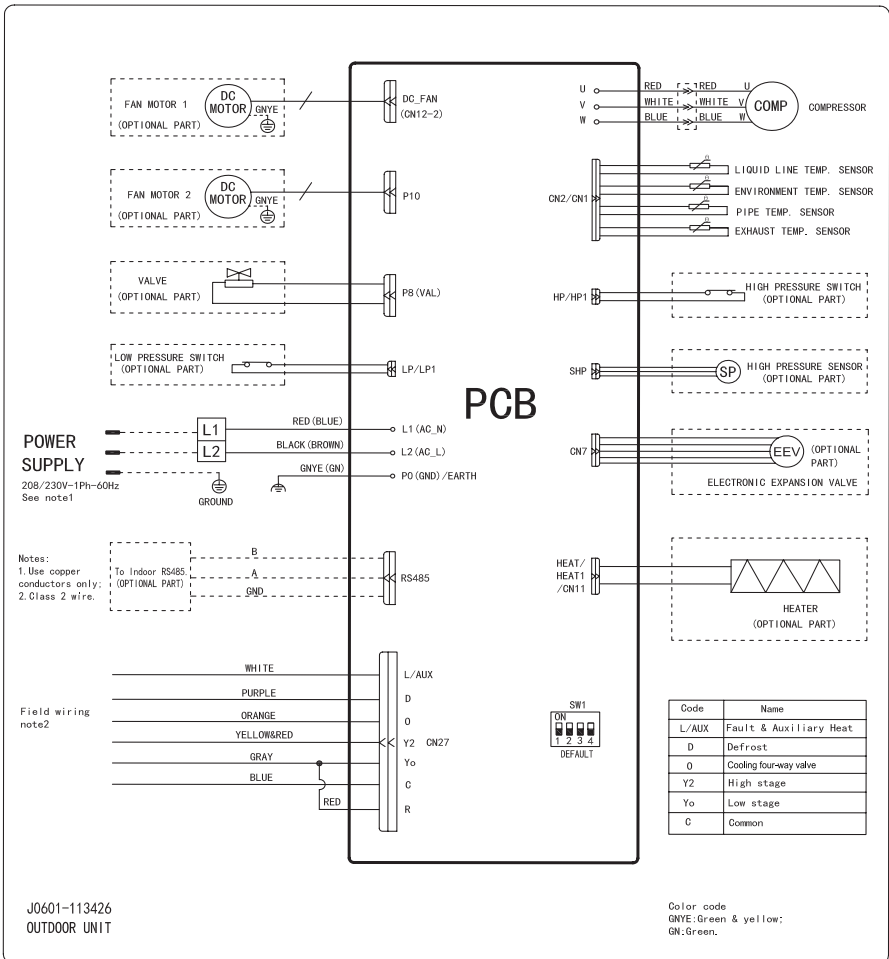

J0601-113426
 OUTDOOR UNIT

Disposal Guideline

- 1) Minimum installation height, minimum room area (operating or storage) refer to installation manual.
- 1) La taille minimale d'installation, la surface minimale de pièce (opération ou stockage) se réfèrent au manuel d'installation.
- 2) Risk of fire-auxiliary devices which may be ignition sources shall not be installed in the ductwork, other than auxiliary devices listed for use with the specific appliance. See instructions.
- 2) Risque d'incendie-l'équipement auxiliaire qui peut être une source d'inflammation ne doit pas être installé dans le système de tuyauterie, à l'exception de l'équipement auxiliaire utilisé avec un équipement spécifique. Voir les instructions.
- 3) Mount with the lowest moving parts at least 2.5m (8.2ft) above floor or grade level.
- 3) Installé avec la partie mobile la plus basse au moins 2.5m (8.2ft) au-dessus du sol ou du plan du sol.
- 4) Risk of electric shock. Can cause injury or death. Disconnect all remote electric power supplies before servicing.
- 4) Risque de choc électrique. Causer des blessures ou la mort. Avant la réparation, débranchez toute alimentation à distance.
- 5) Risk of fire. Flammable refrigerant used. To be repaired only by trained service personnel. Do not puncture refrigerant tubing.
- 5) Risque d'incendie. Utilisation de réfrigérants inflammables. L'entretien ne peut être effectué que par un personnel de maintenance formé. Ne pas percer la ligne de réfrigérant.
- 6) Risk of fire. Dispose of properly in accordance with federal or local regulations. Flammable refrigerant used.
- 6) Risque d'incendie. Disposer correctement conformément à la réglementation fédérale ou locale. Utilisation de réfrigérants inflammables.
- 7) Risk of fire. Flammable refrigerant used. Consult repair manual/owner's guide before attempting to service this product. All safety precautions must be followed.
- 7) Risque d'incendie. Utilisation de réfrigérants inflammables. Veuillez consulter le manuel de réparation/guide de l'utilisateur avant d'essayer de réparer ce produit. Toutes les précautions de sécurité doivent être respectées.
- 8) Risk of fire. Due to flammable refrigerant used. Follow handling instructions carefully in compliance with national regulations.
- 8) Risque d'incendie causé par l'utilisation de réfrigérants inflammables. Suivez attentivement les instructions de manutention conformément aux réglementations nationales.
- 9) Warning: Before accessing the terminals, all power supply circuits must be disconnected.
- 9) Avertissement: Avant d'accéder aux bornes de raccordement, tous les circuits d'alimentation doivent être déconnectés.





Intertek

The AHRI Certified mark indicates company participation in the AHRI Certification program. For verification of individual certified products, go to ahridirectory.org.

The manufacturer has a policy of continuous data improvement and it reserves the right to change design and specifications without notice. We are committed to using environmentally conscious print practices.