



R32 TOP-DISCHARGE DUCTED AIR HANDLER INSTALLATION MANUAL

Models Covered:
ACiQ-24TD-AH32
ACiQ-36TD-AH32
ACiQ-48TD-AH32
ACiQ-60TD-AH32



NOTE: Appearance of unit may vary. Installation must be performed in accordance with the requirements of NEC and CEC by authorized personnel only.

All phases of this installation must comply with National, State and Local Codes.

This document is customer's property and is to remain with this unit. Please return it to customer with service information upon completion of work.

These instructions are intended as an assist to qualified and licensed personnel for proper installation, adjustment and operation of ECM air handler units. Read it thoroughly before attempting installation or service work.





Failure to follow these instructions may result in fire, electrical shock, property damage, personal injury or death.

The instructions do not cover all variations in systems or provide for every possible contingency to be met in connection with the installation.



VERSION DATE: 02-24-26

Safety Notice

| | |
|---|--|
|  A2L  A2L | Caution: Risk of fire. The air conditioner is charged with inflammable refrigerant R32. |
|  | Before using the air conditioner, please read the instruction manual first. |
|  | Before installing the air conditioner, please read the instruction manual first. |
|  | Before repairing the air conditioner, please read the technical service manual first. |

Compared with common refrigerant, R32 is an environmental-friendly refrigerant that has no harm to the ozone layer and weak greenhouse effect. Its GWP is 675. Because of its thermodynamic characteristics, R32 requires a smaller charging quantity to reach high energy efficiency. It is inflammable and odorless, but may cause explosion under certain circumstances.

CONTENTS

| | |
|--|----|
| Precautions | 1 |
| Instruction for Servicing (R32) | 4 |
| Dimensions | 19 |
| Applications | 21 |
| Electrical Wiring | 32 |
| Airflow Performance | 36 |
| Ductwork | 38 |
| Air Filter | 39 |
| Refrigerant Sensor | 40 |
| Internal Function Dip Switch Description | 41 |
| Fault Indication | 44 |
| Troubleshooting | 46 |
| Electrical | 48 |
| Disposal Guideline | 56 |

Precautions

SAFETY RULES AND RECOMMENDATIONS FOR THE INSTALLER

1. **R**ead this guide before installing and using the appliance.
2. **D**uring the installation of the indoor and outdoor units, access to the working area should be forbidden to children. Unforeseeable accidents could happen.
3. **M**ake sure that the base of the outdoor unit is firmly fixed.
4. **C**heck that air cannot enter the refrigerant system and check for refrigerant leaks before turning on the air conditioner.
5. **C**arry out a test cycle after installing the air conditioner and record the operating data.
6. **P**rotect the unit with a fuse of suitable capacity for the maximum input current or with another overload protection device.
7. **E**nsure that the mains voltage matches the voltage indicated on the nameplate. Keep the switch clean and ensure that the power cord terminals are correctly connected to the circuit. This prevents the risk of electric shock or fire caused by poor contact.
8. **T**he appliance must be equipped with devices capable of disconnection from the mains power supply, have a contact separation in all poles to provide full disconnection under "over voltage category III conditions", these devices must also be incorporated into the fixed wiring in accordance with the wiring rules.
9. **T**he air conditioner must be installed by professional or qualified persons. Do not try to install the conditioner alone, always contact specialized technical personnel.
10. **D**o not install the appliance at a distance of less than 50 cm from inflammable substances (alcohol, etc.) or from pressurized containers (e. g. spray cans).
11. **I**f the appliance is used in areas without the possibility of ventilation, precautions must be taken to prevent any leaks of refrigerant gas from remaining in the environment and creating a danger of fire.
12. **T**he packaging materials are recyclable and should be disposed of in the separate waste bins. Take the air conditioner at the end of its useful life to a special waste collection center for disposal.
13. **O**nly use the air conditioner as instructed in this booklet. These instructions are not intended to cover every possible condition and situation. As with any electrical household appliance, common sense and caution are therefore always recommended for installation, operation and maintenance.
14. **T**he appliance must be installed in accordance with applicable national regulations.
15. **B**efore accessing the terminals, all the power circuits must be disconnected from the power supply.

-
16. **T**his appliance can be used by children aged from 8 years and above and persons with reduced physical, sensory or mental capabilities or lack of experience and knowledge if they have been given supervision or instruction concerning use of the appliance in a safe way and understand the hazards involved. Children should not play with the appliance. Cleaning and user maintenance should not be made by children without supervision.
 17. **C**leaning and maintenance must be carried out by specialized technical personnel. In any case disconnect the appliance from the mains electricity supply before carrying out any cleaning or maintenance.
 18. **T**his appliance has been made for air conditioning domestic environments and must not be used for any other purpose, such as for drying clothes, cooling food, etc.
 19. **A**lways use the appliance with the air filter mounted. Air conditioning without air filter could cause an excessive accumulation of dust and/or lead to inner parts function failure.
 20. **T**he user is responsible for having the appliance installed by a qualified technician, who must check that earthing/grounding is done in accordance with current legislation and insert a thermal-magnetic circuit breaker.
 21. **T**he batteries in the remote controller must be recycled or disposed of properly. For disposal of scrap batteries, please discard the batteries as sorted municipal waste at the accessible collection point.
 22. **N**ever remain directly exposed to the flow of cold air for a long time. The direct and prolonged exposure to cold air could be dangerous for your health. Particular care should be taken in the rooms where there are children, old or sick people.
 23. **I**f the appliance gives off smoke or there is a smell of burning, immediately cut off the power supply and contact the Service Center. The prolonged use of the device in such conditions could cause fire or electrocution.
 24. **H**ave repairs carried out only by an authorized Service Center of the manufacturer. Incorrect repair could expose the user to the risk of electric shock, etc.
 25. **U**nhook the switch if you foresee not to use the device for a long time. The airflow direction must be properly adjusted.
 26. **T**he flaps must be directed downwards in the heating mode and upwards in the cooling mode.
 27. **E**nsure that the appliance is disconnected from the power supply when it is intended to remain inoperative for a long period and before carrying out any cleaning or maintenance.
 28. **S**electing the most suitable temperature can prevent damage to the appliance.

SAFETY RULES AND PROHIBITIONS

1. **D**o not bend, tug or compress the power cord since this could damage it. Electrical shocks or fire are probably due to a damaged power cord. Only specialized technical personnel are recommended to replace a damaged power cord.
2. **D**o not use extensions or gang modules.
3. **D**o not touch the appliance when barefoot or parts of the body are wet or damp.
4. **D**o not obstruct the air inlet or outlet of the indoor or the outdoor unit. The obstruction of these openings causes a reduction in the operative efficiency of the conditioner with possible consequent failures or damages.
5. **I**n no way alter the characteristics of the appliance.
6. **D**o not install the appliance in environments where the air could contain flammable gas, oil or sulphur or near sources of heat.
7. **T**his appliance is not intended for use by persons (including children) with reduced physical, sensory or mental capabilities, or lack of experience and knowledge, unless they have been given supervision or instruction concerning use of the appliance by a person responsible for their safety.
8. **D**o not climb onto or place any heavy or hot objects on top of the appliance.
9. **D**o not leave windows or doors open for long time when the air conditioner is operating.
10. **D**o not direct the airflow onto plants or animals.
11. **L**ong direct exposure to the flow of cold air of the conditioner could have negative effects on plants and animals.
12. **D**o not put the conditioner in contact with water. The electrical insulation could be damaged and thus cause electrocution.
13. **D**o not climb onto or place any objects on the outdoor unit.
14. **N**ever insert a stick or similar object into the appliance. It could cause injury.
15. **C**hildren should be supervised to ensure that they do not play with the appliance.
16. **T**his unit is equipped with a refrigerant leak detector for safety.
17. **T**his refrigerant sensor is only replaced with a manufacturer approved sensor. If the sensor is replaced only as part of the component assembly, the component should be labeled.
(Some models have refrigerant leak sensors, subject to the actual product received.)
18. **T**he appliance shall be installed according to the manufacturer's instructions, and the ventilation pipe shall not exceed the maximum length and number of turns specified by the manufacturer.
19. **A**ppliances shall be installed according to the instructions. Appliances that can be installed in different locations should be tested in all locations permitted by the manufacturer. The intake or exhaust openings should not be covered and the manufacturer's recommended air filter should be installed according to the instructions.

20. LEAK DETECTION SYSTEM installed. Unit must be powered except for service.

NOTE(WiFi models only)

This device complies with Part 15 of the FCC Rules. Operation is subject to the following two conditions:

1. This device may not cause harmful interference.
2. This device must accept any interference received, including interference that may cause undesired operation.

Instruction for Servicing (R32)

1. Check the information in this manual to find out the dimensions of space needed for proper installation of the device, including the minimum distances allowed compared to adjacent structures.
2. Appliance shall be installed, operated and stored in a room with a floor area larger than 58m².
3. The installation of pipe-work shall be kept to a minimum.
4. The pipe-work shall be protected from physical damage, and shall not be installed in an unventilated space if the space is smaller than 58m².
5. The compliance with national gas regulations shall be observed.
6. The mechanical connections shall be accessible for maintenance purposes.
7. Follow the instructions given in this manual for handling, installing, cleaning, maintaining and disposing of the refrigerant.
8. Make sure ventilation openings are clear of obstruction.
9. **Notice:** The servicing shall be performed only as recommended by the manufacturer.
10. **Warning:** The appliance shall be stored in a well-ventilated area where the room size corresponds to the room area as specified for operation.
11. **Warning:** The appliance shall be stored in a room without continuously operating open flames (for example an operating gas appliance) and ignition sources (for example an operating electric heater).
12. The appliance shall be stored so as to prevent mechanical damage from occurring.
13. It is appropriate that anyone who is called upon to work on a refrigerant circuit should hold a valid and up-to-date certificate from an assessment authority accredited by the industry and recognizing their competence to handle refrigerants, in accordance with the assessment specification recognized in the industrial sector concerned. Service operations should only be carried out in accordance with the recommendations of the equipment manufacturer. Maintenance and repair operations that require the assistance of other qualified persons must be conducted under the supervision of the person competent for the use of flammable refrigerants.
14. Every working procedure that affects safety factors shall only be carried out by specialized persons.

15. Warning:

- * Do not use any means to accelerate the defrosting process or clean the frost on your own. Follow the recommended guidelines from the manufacturer.
- * The appliance shall be stored in a room without continuously operating ignition sources (for example: Open flames, an operating gas appliance or an operating electric heater).
- * Do not pierce or burn.
- * Be aware that refrigerants may not contain an odor.

Important Considerations

- 1) The air conditioner must be installed by professional personnel and the Installation manual is used only for the professional installation personnel! The installation specifications should be subject to our after-sale service regulations.
- 2) When filling the combustible refrigerant, any of your rough operations may cause serious injuries to human body and objects.
- 3) A leak test must be done after the installation completed.
- 4) It is a must to do the safety inspection before maintaining or repairing an air conditioner using combustible refrigerant in order to ensure that the fire risk is reduced to minimum.
- 5) It is necessary to operate the machine under a controlled procedure in order to ensure that any risk arising from the combustible gas or vapor during the operation is reduced to minimum.
- 6) Requirements for the total weight of filled refrigerant and the area of a room to be equipped with an air conditioner (are shown as in the following tables).

The maximum charge and the required minimum floor area

$$m_1 = (6 \text{ m}^3) \times \text{LFL}, m_2 = (52 \text{ m}^3) \times \text{LFL}, m_3 = (260 \text{ m}^3) \times \text{LFL}$$

Where LFL is the lower flammable limit in kg/ m³, R32 LFL is 0.306 kg/ m³.

For the appliances with a charge amount $m_1 < M = m_2$:

The maximum charge in a room shall be in accordance with the following:

$$M_{\text{max}} = \text{SF} \times \text{LFL} \times h_0 \times A$$

The required minimum floor area A_{min} to install an appliance with refrigerant charge $M(\text{kg})$ shall be in accordance with following: $A_{\text{min}} = M / (\text{SF} \times \text{LFL} \times h_0)$

Refrigerant Charge and Room Area Limitations

In UL/CSA 60335-2-40, R32 refrigerant is classified as class A2L, which is mildly flammable.

Therefore, R32 refrigerant is suitable for systems needing additional refrigerant charge and which will limit the area of the rooms being served by the system. Similarly, the total amount of refrigerant in the system shall be less than or equal to the allowable maximum refrigerant charge. The allowable

maximum refrigerant charge depends on the area of the rooms being served by the system.

NOTE:

The terms in this section are explained as follows:

Mc: The actual refrigerant charge in the system.

A: The actual room area where the appliance is installed.

Amin: The required minimum room area.

Mmax: The allowable maximum refrigerant charge in a room.

Qmin: The minimum circulation airflow.

Anvmin: The minimum opening area for connected rooms.

TAmin: The total area of the conditioned space (For appliances serving one or more rooms with an air duct system).

TA: The total area of the conditioned space connected by air ducts.

CAUTION:

The space considered shall be any space which contains refrigerant-containing parts or into which refrigerant could be released.

The room area (A) of the smallest, enclosed, occupied space shall be used in the determination of the refrigerant quantity limits.

For determination of room area (A) when used to calculate the refrigerant charge limit, the following shall apply.

The room area (A) shall be defined as the room area enclosed by the projection to the base of the walls, partitions and doors of the space in which the appliance is installed.

Spaces connected by only drop ceilings, ductwork, or similar connections shall not be considered a single space.

Units mounted higher than 70-55/64 inches and spaces divided by partition walls that are no higher than 62-63/64 inches shall be considered a single space.

Rooms on the same floor and connected by an open passageway between the spaces can be considered a single room when determining compliance to Amin, if the passageway complies with all of the following.

- 1) It is a permanent opening.
- 2) It extends to the floor.
- 3) It is intended for people to walk through.

The area of the connected rooms, on the same floor, connected by permanent opening in the walls and/ or doors between occupied spaces, including gaps between the wall and the floor can be considered a single room when determining compliance to Anvmin, provided all of the following conditions are met as fig.2-1.

Low level opening

- 1) The opening shall not be less than Anvmin in Table 2-1.
- 2) The area of any openings above 11-13/16 inches from the floor shall not be considered in determining compliance with Anvmin.
- 3) At least 50% of the opening area of Anvmin shall be below 7-7/8 inches from the floor.
- 4) The bottom of the opening is not more than 3-15/16 inches from the floor.
- 5) The opening is a permanent opening that cannot be closed.
- 6) For openings extending to the floor the height shall not be less than 25/32 inches above the surface of the floor covering.

High level opening

- 1) The opening shall not be less than 50% of Anvmin in Table 2-1.
- 2) The opening is a permanent opening that cannot be closed.
- 3) The opening shall be at least 59 inches above the floor.
- 4) The height of the opening is not less than 25/32 inches.

NOTE:

The requirement for the second opening can be met by drop ceilings, ventilation ducts, or similar arrangements that provide an airflow path between the connected rooms.

The minimum opening for natural ventilation (Anvmin) in connected rooms is related to the room area (A), the actual refrigerant charge of refrigerant in the system (Mc), and the allowable MAXIMUM REFRIGERANT CHARGE in the system (Mmax), Anvmin can be determined according to Table 2-1.

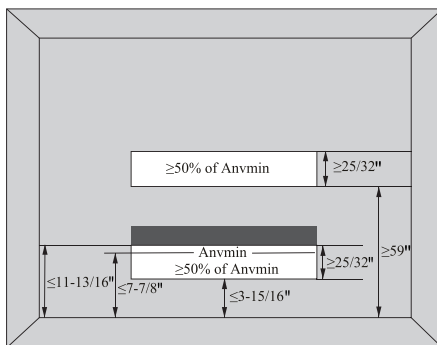

Fig.2-1 Opening Conditions for Connected Rooms

The minimum opening area for connected rooms

Table 2-1

| A(ft ²) | Mc(□lbs□oz) | | Mmax(□lbs□oz) | | Anvmin(ft ²) |
|---------------------|-------------|----|---------------|----|--------------------------|
| | lbs | oz | lbs | oz | |
| 40 | 7 | 12 | 2 | 12 | 0.7 |
| 50 | 7 | 12 | 3 | 7 | 0.6 |
| 60 | 7 | 12 | 4 | 2 | 0.5 |
| 70 | 7 | 12 | 4 | 13 | 0.4 |
| 80 | 7 | 12 | 5 | 8 | 0.3 |
| 90 | 7 | 12 | 6 | 3 | 0.2 |
| 100 | 7 | 12 | 6 | 14 | 0.1 |
| 110 | 7 | 12 | 7 | 9 | 0.1 |
| 120 | 7 | 12 | 8 | 4 | 0.0 |
| 130 | 7 | 12 | 8 | 15 | 0.0 |
| 140 | 7 | 12 | 9 | 10 | 0.0 |
| 150 | 7 | 12 | 10 | 4 | 0.0 |
| 160 | 7 | 12 | 10 | 10 | 0.0 |

Note: Take the Mc=7 lbs 12 oz as an example.

For appliances serving one or more rooms with an air duct system, The room area calculation shall be determined based on the total area of the conditioned space (TA) connected by ducts taking into consideration that the circulating airflow distributed to all the rooms by the appliance integral indoor fan will mix and dilute the leaking refrigerant before entering any room.

The allowed maximum refrigerant charge and required minimum room area

If the fan incorporated to an appliance is continuously operated or operation is initiated by a REFRIGERANT DETECTION SYSTEM with a sufficient CIRCULATION AIRFLOW rate, the allowable maximum refrigerant charge (Mmax) and the required minimum room area (Amin/TAmin) is shown in Table 2-2 and Table 2-3.

The allowable maximum refrigerant charge

Table 2-2

| A/TA(ft ²) | Mc(□lbs□oz) | | A/TA(ft ²) | Mmax(□lbs□oz) | |
|------------------------|-------------|----|------------------------|---------------|----|
| | lbs | oz | | lbs | oz |
| 40 | 2 | 12 | 160 | 10 | 9 |
| 50 | 3 | 7 | 170 | 10 | 15 |
| 60 | 4 | 2 | 180 | 11 | 4 |
| 70 | 4 | 13 | 190 | 11 | 9 |
| 80 | 5 | 8 | 200 | 11 | 13 |
| 90 | 6 | 3 | 210 | 12 | 2 |
| 100 | 6 | 14 | 220 | 12 | 7 |
| 110 | 7 | 9 | 230 | 12 | 11 |
| 120 | 8 | 4 | 240 | 13 | 0 |
| 130 | 8 | 15 | 250 | 13 | 4 |
| 140 | 9 | 10 | 260 | 13 | 8 |
| 150 | 10 | 4 | | | |

The required minimum room area

Table 2-3

| Mc(□lbs□oz) | | Amin/Tamin(ft ²) | Mmax(□lbs□oz) | | Amin/Tamin(ft ²) |
|-------------|----|------------------------------|---------------|----|------------------------------|
| lbs | oz | | lbs | oz | |
| 4 | 0 | 58.1 | 11 | 0 | 171.3 |
| 4 | 8 | 65.4 | 11 | 8 | 187.2 |
| 5 | 0 | 72.6 | 12 | 0 | 203.9 |
| 5 | 8 | 79.9 | 12 | 8 | 221.2 |
| 6 | 0 | 87.1 | 13 | 0 | 239.3 |
| 6 | 8 | 94.4 | 13 | 8 | 258.0 |
| 7 | 0 | 101.6 | 14 | 0 | 277.5 |
| 7 | 8 | 108.9 | 14 | 8 | 297.6 |
| 8 | 0 | 116.2 | 15 | 0 | 318.5 |
| 8 | 8 | 123.4 | 15 | 8 | 340.1 |
| 9 | 0 | 130.7 | 16 | 0 | 362.4 |
| 9 | 8 | 137.9 | 16 | 8 | 385.4 |
| 10 | 0 | 145.2 | 17 | 0 | 409.1 |
| 10 | 8 | 156.1 | 17 | 8 | 433.5 |

The minimum circulation airflow

Table 2-4

| Mc(□lbs□oz) | | Qmin(CFM) | Mmax(□lbs□oz) | | Qmin(CFM) |
|-------------|----|-----------|---------------|----|-----------|
| lbs | oz | | lbs | oz | |
| 4 | 0 | 105 | 11 | 0 | 289 |
| 4 | 8 | 118 | 11 | 8 | 302 |
| 5 | 0 | 131 | 12 | 0 | 315 |
| 5 | 8 | 145 | 12 | 8 | 328 |
| 6 | 0 | 158 | 13 | 0 | 341 |
| 6 | 8 | 171 | 13 | 8 | 354 |
| 7 | 0 | 184 | 14 | 0 | 367 |
| 7 | 8 | 197 | 14 | 8 | 380 |
| 8 | 0 | 210 | 15 | 0 | 393 |
| 8 | 8 | 223 | 15 | 8 | 406 |
| 9 | 0 | 236 | 16 | 0 | 419 |
| 9 | 8 | 249 | 16 | 8 | 433 |
| 10 | 0 | 262 | 17 | 0 | 446 |
| 10 | 8 | 275 | 17 | 8 | 459 |

CAUTION:

The allowable maximum refrigerant charge of the Table 2-2 or the required minimum room area of the Table 2-3 is available only if the following conditions are met:

Minimum velocity of 3.28ft/s, which is calculated as the indoor unit airflow divided by the nominal face area of the outlet. And the grill area shall not be deducted.

Minimum airflow rate must meet the corresponding values in Table 2-4, which is related to the actual

refrigerant charge of the system (Mc).

R32 refrigerant leakage sensor is configured.

If the safety protection function depends on continuous air circulation, the following shall apply: Continuous air circulation is required for proper operation. The unit must remain powered on except during maintenance.

NOTE:

The maximum refrigerant limit described above applies to unventilated areas. If adding additional measures, such as areas with mechanical ventilation or natural ventilation, the maximum refrigerant charge can be increased or the minimum room area can be reduced.

R32 refrigerant leakage sensor is configured for the indoor unit, meets the incorporated circulation airflow requirements, the maximum refrigerant charge or minimum room area can be determined according to Table 2-2 or Table 2-3.

CAUTION:

If the actual room area, air outlet height, and refrigerant charge amount are not reflected in the above table, more severe cases need to be considered according to the data in the table 2-1, 2-2, 2-3, 2-4.



Caution: Risk of fire

$\geq Am^2$
A2L



Read operator's manual



Operating instructions



Caution: Risk of fire

A2L



Read technical manual

16. Information on servicing:

1) Checks to the area

Prior to beginning work on systems containing flammable refrigerants, safety checks are necessary

to ensure that the risk of ignition is minimized. For repair to the refrigerating system, the following precautions shall be complied with prior to conducting work on the system.

2) Work procedure

Work shall be undertaken under a controlled procedure so as to minimize the risk of a flammable gas or vapor being present while the work is being performed.

3) General work area

All maintenance staff and others working in the local area shall be instructed on the nature of work being carried out. Work in confined spaces shall be avoided. The area around the workspace shall be sectioned off. Ensure that the conditions within the area have been made safe by control of flammable material.

4) Checking for presence of refrigerant

The area shall be checked with an appropriate refrigerant detector prior to and during work, to ensure the technician is aware of potential flammable atmospheres. Ensure that the leak detection equipment being used is suitable for use with flammable refrigerants, i.e. non-sparking, adequately sealed or intrinsically safe.

5) Presence of fire extinguisher

If any hot work is to be conducted on the refrigeration equipment or any associated parts, appropriate fire extinguishing equipment shall be available to hand. Have a dry powder or CO₂ fire extinguisher adjacent to the charging area.

6) No ignition sources

No person carrying out work in relation to a refrigeration system which involves exposing any pipe work shall use any sources of ignition in such a manner that it may lead to the risk of fire or explosion. All possible ignition sources, including cigarette smoking, should be kept sufficiently far away from the site of installation, repairing, removing and disposal, during which refrigerant can possibly be released to the surrounding space. Prior to work taking place, the area around the equipment is to be surveyed to make sure that there are no flammable hazards or ignition risks. "No Smoking" signs shall be displayed.

7) Ventilated area

Ensure that the area is in the open or that it is adequately ventilated before breaking into the system or conducting any work that will produce heat. A degree of ventilation shall continue during the period that the work is carried out. The ventilation should safely disperse any released refrigerant and preferably expel it externally into the atmosphere.

8) Checks to the refrigeration equipment

Where electrical components are being changed, they shall be fit for the purpose and to the correct specification. At all times the manufacturer's maintenance and service guidelines shall be followed.

If in doubt consult the manufacturer's technical department for assistance.

The following checks shall be applied to installation using flammable refrigerant:

- The charge size is in accordance with the room size within which the refrigerant containing parts are installed;
- The ventilation machinery and outlets are operating adequately and are not obstructed;
- If an indirect refrigerating circuit is being used, the secondary circuit shall be checked for the presence of refrigerant;
- Marking to the equipment continues to be visible and legible. Markings and signs that are illegible shall be corrected;
- Refrigeration pipe or components are installed in a position where they are unlikely to be exposed to any substance which may corrode refrigerant containing components, unless the components are constructed of materials which are inherently resistant to being corroded or are suitably protected against being so corroded.

9) Checks to electrical devices

Repair and maintenance to electrical components shall include initial safety checks and component inspection procedures. If a fault exists that could compromise safety, then no electrical supply shall be connected to the circuit until it is satisfactorily dealt with. If the fault cannot be corrected immediately but it is necessary to continue operation, an adequate temporary solution shall be used. This shall be reported to the owner of the equipment so all parties are advised.

Initial safety checks shall include:

- That capacitors are discharged: This shall be done in a safe manner to avoid possibility of sparking;
- That no live electrical components and wiring are exposed while charging, recovering or purging the system;
- That there is continuity of earth bonding.

17. Repairs to sealed components

Sealed electrical components shall be replaced.

18. Repair to intrinsically safe components

Intrinsically safe components must be replaced.

19. Cabling

Check that cabling will not be subject to wear, corrosion, excessive pressure, vibration, sharp edges or any other adverse environmental effects. The check shall also take into account the effects of aging or continual vibration from sources such as compressors or fans.

20. Detection of flammable refrigerants

Under no circumstances shall potential sources of ignition be used in the searching for or detection of refrigerant leaks. A halide torch (or any other detector using a naked flame) shall not be used.

21. Leak detection methods

The following leak detection methods are deemed acceptable for systems containing flammable refrigerants.

Electronic leak detectors shall be used to detect flammable refrigerants, but the sensitivity may not be adequate, or may need re-calibration. (Detection equipment shall be calibrated in a refrigerant-free area.) Ensure that the detector is not a potential source of ignition and is suitable for the refrigerant used. Leak detection equipment shall be set at a percentage of the LFL of the refrigerant and shall be calibrated to the refrigerant employed and the appropriate percentage of gas (25 % maximum) is confirmed. Leak detection fluids are suitable for use with most refrigerants but the use of detergents containing chlorine shall be avoided as the chlorine may react with the refrigerant and corrode the copper pipe-work. If a leak is suspected, all naked flames shall be removed/ extinguished. If a leakage of refrigerant is found which requires brazing, all of the refrigerant shall be recovered from the system, or isolated (by means of shut off valves) in a part of the system remote from the leak. Oxygen free nitrogen (OFN) shall then be purged through the system both before and during the brazing process.

22. Removal and evacuation

When breaking into the refrigerant circuit to make repairs or for any other purpose conventional procedures shall be used. However, it is important that best practice is followed since inflammability is a consideration. The following procedure shall be adhered to:

- Remove refrigerant;
- Purge the circuit with inert gas;
- Evacuate;
- Purge again with inert gas;
- Open the circuit by cutting or brazing.

The refrigerant charge shall be recovered into the correct recovery cylinders. The system shall be flushed with OFN to render the unit safe. This process may need to be repeated several times.

Compressed air or oxygen shall not be used for this task.

Flushing shall be achieved by breaking the vacuum in the system with OFN and continuing to fill until the working pressure is achieved, then venting to atmosphere, and finally pulling down to a vacuum. This process shall be repeated until no refrigerant is within the system. When the final OFN charge is used, the system shall be vented down to atmospheric pressure to enable work to take place. This operation is absolutely vital if brazing operations on the pipe-work are to take place.

Ensure that the outlet for the vacuum pump is not close to any ignition sources and there is ventilation available.

23. Decommissioning

Before carrying out this procedure, it is essential that the technician is completely familiar with the equipment and all its details. It is recommended good practice that all refrigerants are recovered safely.

Prior to the task being carried out, an oil and refrigerant sample shall be taken in case analysis is required prior to re-use of reclaimed refrigerant. It is essential that electrical power is available before the task is commenced.

- 1) Become familiar with the equipment and its operation.
- 2) Isolate system electrically.
- 3) Before attempting the procedure, ensure that:
 - Mechanical handling equipment is available, if required, for handling refrigerant cylinders;
 - All personal protective equipment is available and being used correctly;
 - The recovery process is supervised at all times by a competent person;
 - Recovery equipment and cylinders conform to the appropriate standards.
- 4) Pump down refrigerant system, if possible.
- 5) If a vacuum is not possible, make a manifold so that refrigerant can be removed from various parts of the system.
- 6) Make sure that cylinder is situated on the scales before recovery takes place.
- 7) Start the recovery machine and operate in accordance with manufacturer's instructions.
- 8) Do not overfill cylinders. (No more than 80% volume liquid charge).
- 9) Do not exceed the maximum working pressure of the cylinder, even temporarily.
- 10) When the cylinders have been filled correctly and the process completed, make sure that the cylinders and the equipment are removed from site promptly and all isolation valves on the equipment are closed off.
- 11) Recovered refrigerant shall not be charged into another refrigeration system unless it has been cleaned and checked.

24. Labeling

Equipment shall be labeled stating that it has been de-commissioned and emptied of refrigerant. The label shall be dated and signed. Ensure that there are labels on the equipment stating the equipment contains flammable refrigerant.

25. Recovery

When removing refrigerant from a system, either for servicing or decommissioning, it is recommended good practice that all refrigerants are removed safely.

When transferring refrigerant into cylinders, ensure that only appropriate refrigerant recovery cylinders are employed. Ensure that the correct number of cylinders for holding the total system charge are available. All cylinders to be used are designated for the recovered refrigerant and labeled for that refrigerant (i.e. Special cylinders for the recovery of refrigerant). Cylinders shall be complete with pressure-relief valve and associated shut-off valves in good working order.

Empty recovery cylinders are evacuated and, if possible, cooled before recovery occurs.

The recovery equipment shall be in good working order with a set of instructions concerning the equipment that is at hand and shall be suitable for the recovery of all appropriate refrigerants including, when applicable, flammable refrigerants. In addition, a set of calibrated weighing scales shall be available and in good working order. Hoses shall be complete with leak-free disconnect couplings and in good condition. Before using the recovery machine, check that it is in satisfactory working order, has been properly maintained and that any associated electrical components are sealed to prevent ignition in the event of a refrigerant release. Consult manufacturer if in doubt.

The recovered refrigerant shall be returned to the refrigerant supplier in the correct recovery cylinder, and the relevant waste transfer note arranged. Do not mix refrigerants in recovery units and especially not in cylinders.

If compressors or compressor oils are to be removed, ensure that they have been evacuated to an acceptable level to make certain that flammable refrigerant does not remain within the lubricant.

The evacuation process shall be carried out prior to returning the compressor to the suppliers.

Only electric heating to the compressor body shall be employed to accelerate this process. When oil is drained from a system, it shall be carried out safely.

26. Warning:

- 1) Do not use means to accelerate the defrosting process or to clean, other than those recommended by the manufacturer.
- 1) Ne pas utiliser de produits permettant d'accélérer le dégel ou de produits de nettoyage autres que ceux recommandés par le fabricant.
- 2) The appliance shall be stored in a room without continuously operating ignition sources (for example: Open flames, an operating gas appliance or an operating electric heater).
- 2) L'appareil doit être entreposé dans un endroit sans source d'allumage fonctionnant en continu (par exemple: Flamme nue, appareil au gaz en marche ou radiateur électrique en marche).
- 3) Do not pierce or burn.
- 3) Ne pas percer ni brûler.
- 4) Be aware that refrigerants may not contain an odor.
- 4) Attention: Les frigorigènes peuvent être inodores.

27. Statement

- 1) Please use the flammable gas detector to check before unloading and open the container.
- 2) No fire source and smoking.
- 3) That pipe work shall be protected from physical damage and, in the case of FLAMMABLE REFRIGERANTS, shall not be installed in an unventilated space, if that space is smaller than Amin in Annex GG, except for A2L REFRIGERANTS where the installed pipes comply with UL 60335-2-40 Clause. In case of field charge, the effect on REFRIGERANT CHARGE caused by the different

pipe length has to be quantified.

- 4) That compliance with national gas regulations shall be observed.
- 5) Be shipped with a **FLAMMABLE REFRIGERANT CHARGE**. Joints made in the installation between parts of the **REFRIGERATING SYSTEM**, with at least one part charged, shall be made in accordance with the following.
 - A brazed, welded, or mechanical connection shall be made before opening the valves to permit refrigerant to flow between the **REFRIGERATING SYSTEM** parts. A vacuum valve shall be provided to evacuate the interconnecting pipe or any uncharged **REFRIGERATING SYSTEM** part.
 - Mechanical connectors used indoors shall comply with ISO 14903. When mechanical connectors are reused indoors, sealing parts shall be renewed. When flared joints are reused indoors, the flare part shall be refabricated.
 - Refrigerant tubing shall be protected or enclosed to avoid damage.
 - Flexible refrigerant connectors (such as connecting lines between the indoor and outdoor unit) that may be displaced during **NORMAL OPERATION** shall be protected against mechanical damage. Compliance is checked according to the installation instructions and a trial installation, if necessary. For installations with field applied joints that are exposed in the occupied space, these joints shall be at least one of the following:
 - Mechanical joints in compliance with ISO 14903 or UL 207 (U.S. only);
 - Welded or brazed joints; or
 - Joints in enclosures that vent to the unit or to the outside.
- 6) That pipe work including piping material, pipe routing, and installation shall include protection from physical damage in operation and service, and be in compliance with national and local codes and standards, such as ASHRAE 15, ASHRAE 15.2, IAPMO Uniform Mechanical Code, ICC International Mechanical Code, or CSA B52. All field joints shall be accessible for inspection prior to being covered or enclosed;
- 7) That after completion of field piping for split systems, the field pipe work shall be pressure tested with an inert gas and then vacuum tested prior to refrigerant charging, according to the following requirements;
- 8) The appliance shall be stored so as to prevent mechanical damage from occurring.
- 9) Working personnel for maintenance, service and repair operations. Every working procedure that affects safety means shall only be carried out by competent persons according to Annex HH. Examples for such working procedures are:
 - Breaking into the refrigerating circuit;
 - Opening of sealed components;
 - Opening of ventilated enclosures.

Installation Safety Principles

1. Site Safety



Open flames prohibited

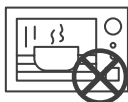

Ventilation necessary

Operation Safety



Mind static electricity



Must wear protective clothing and anti-static gloves



Don't use mobile phone

2. Installation Safety

- Refrigerant Leak Detector
- Appropriate Installation Location

















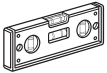

The left picture is the schematic diagram of a refrigerant leak detector.

Please note that:

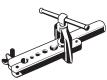
- 1) The installation site should be well-ventilated.
- 2) The sites for installing and maintaining an air conditioner using Refrigerant R32 should be free from open fire or welding, smoking, drying oven or any other heat source higher than 548°C which easily produces open fire.
- 3) When installing an air conditioner, it is necessary to take appropriate anti-static measures such as wear anti-static clothing and/or gloves.
- 4) It is necessary to choose the site convenient for installation or maintenance wherein the air inlets and outlets of the indoor and outdoor units should be not surrounded by obstacles or close to any heat source or combustible and/or explosive environment.
- 5) If the indoor unit suffers refrigerant leak during the installation, it is necessary to immediately turn off the valve of the outdoor unit and all the personnel should go out till the refrigerant leaks completely for 15 minutes. If the product is damaged, it is mandatory to carry such damaged product back to the maintenance station and it is prohibited to weld the refrigerant pipe or conduct other operations on the user's site.
- 6) It is necessary to avoid the places where there are other electrical products, power switch plugs and sockets, kitchen cabinet, bed, sofa and other valuables right under the lines on two sides of the indoor unit.

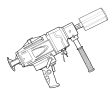
Suggested Tools

| Tool | Picture | Tool | Picture | Tool | Picture |
|--------------------------------|---|---|---|-------------------|--|
| Standard Wrench |  | Pipe Cutter |  | Vacuum Pump |  |
| Adjustable/ Crescent Wrench |  | Screw Drivers (Phillips & Flat Blade) |  | Safety Glasses |  |
| Torque Wrench |  | Manifold and Gauges |  | Work Gloves |  |
| Hex Keys or Allen Wrenches |  | Level |  | Refrigerant Scale |  |
| Drill & Drill Bits |  | Flaring Tool |  | Micron Gauge |  |
| Hole Saw |  | Clamp on Amp Meter |  | Welding Gun |  |

The following information is provided for units that employ FLAMMABLE REFRIGERANTS.

- Transport of equipment containing flammable refrigerants

Attention is drawn to the fact that additional transportation regulations may exist with respect to equipment containing flammable gas. The maximum number of pieces of equipment or the configuration of the equipment permitted to be transported together will be determined by the applicable transport regulations.

- Marking of equipment using signs

Signs for similar appliances used in a work area are generally addressed by local regulations and give the minimum requirements for the provision of safety and/or health signs for a work location.

All required signs are to be maintained and employers should ensure that employees receive suitable and sufficient instruction and training on the meaning of appropriate safety signs and the actions that need to be taken in connection with these signs.

The effectiveness of signs should not be diminished by too many signs being placed together.

Any pictograms used should be as simple as possible and contain only essential details.

- Disposal of equipment using flammable refrigerants

See national regulations.

- Storage of equipment/appliances

The storage of the appliance should be in accordance with the applicable regulations or instructions, whichever is more stringent.

- Storage of packed (unsold) equipment

Storage package protection should be constructed in such a way that mechanical damage to the equipment inside the package will not cause a leak of the REFRIGERANT CHARGE.

The maximum number of pieces of equipment permitted to be stored together will be determined by local regulations.

Dimensions

NOTE: 25" CLEARANCE IS REQUIRED IN THE FRONT OF THE UNIT FOR FILTER AND COIL MAINTENANCE.

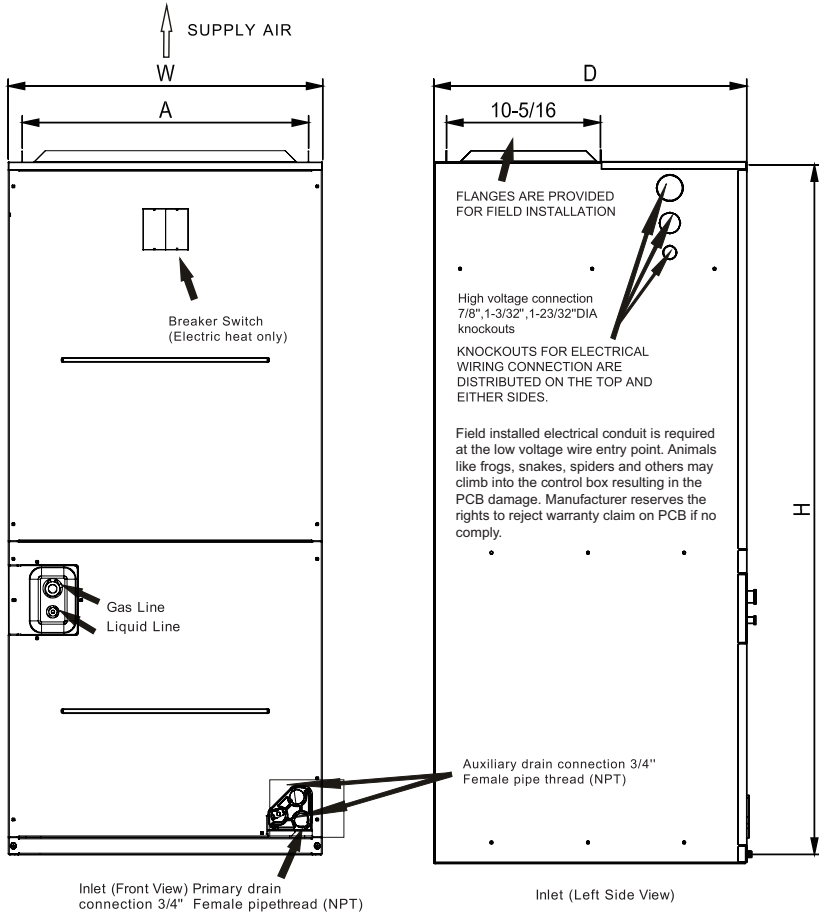

Unit dimensions

Unit Dimensions

| Model | Dimensions (in.) | | | | | |
|------------|------------------|--------|----|--------|------------------------|---------------------|
| | H | W | D | A | Liquid Line Connection | Gas Line Connection |
| 24K 36K | 46-1/2 | 21 | 21 | 19-1/4 | 3/8 | 3/4 |
| 48K 60K | 56 | 24-1/2 | 21 | 22-3/4 | 3/8 | 7/8 |

Select a solid and level site, keep enough space for proper installation and maintenance.

Adjust motor speed tap on indoor main control board (MCB) to select correct air flow according to blower performance table.

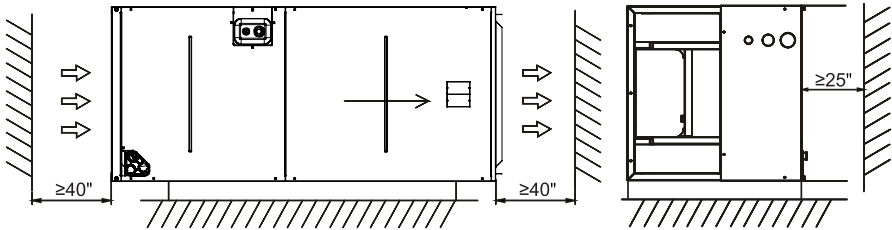

a) Horizontal position

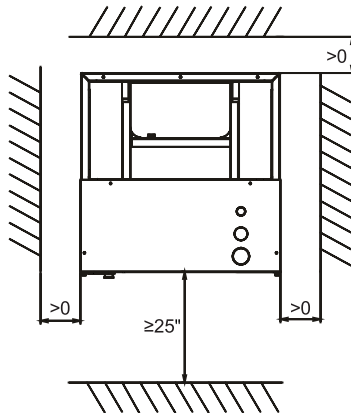

b) Vertical position

Clearance requirement

Applications

Vertical up-flow and Horizontal right-flow(left-flow)

Vertical up-flow and horizontal right-flow configurations are the factory settings on all models.

If return air is to be ducted, install duct flush with floor. Use fireproof resilient gasket 1/8" to 1/4" thick between the ducts, unit and floor. Set unit on floor over opening.

IMPORTANT

Lightly tighten the drain connections so they do not leak.

Using excessive force may cause damage to the drain connections. Torque applied to drain connections should not exceed 10 ft.lbs.

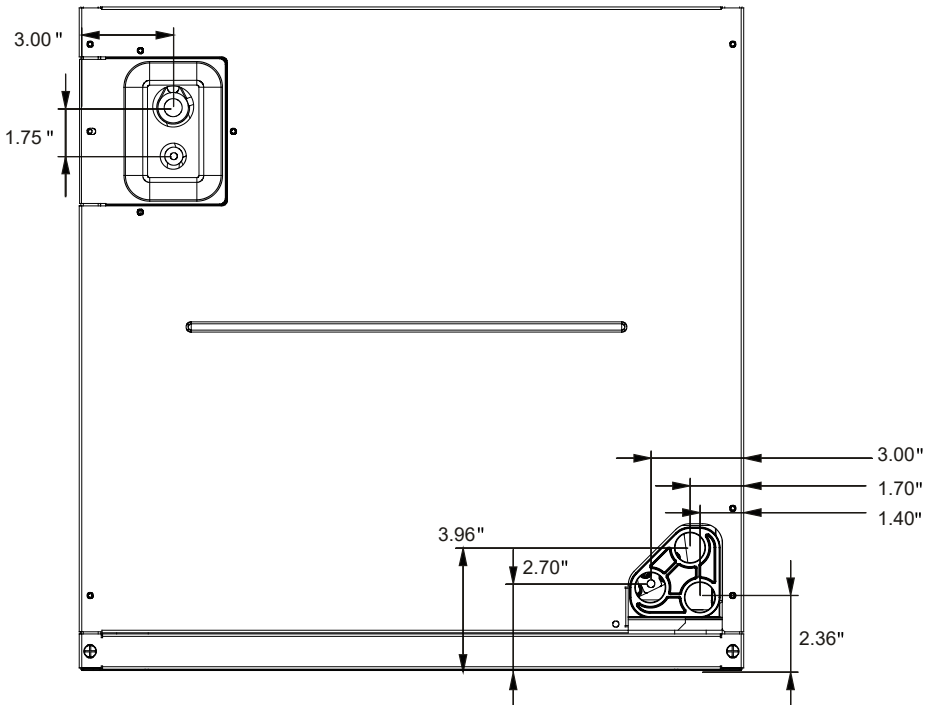

Dimensions for front connection coil

The units can be installed in a Vertical (down and up) and Horizontal (right and left) configuration.

Vertical up installations

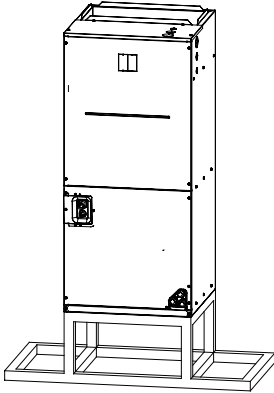

Horizontal installations

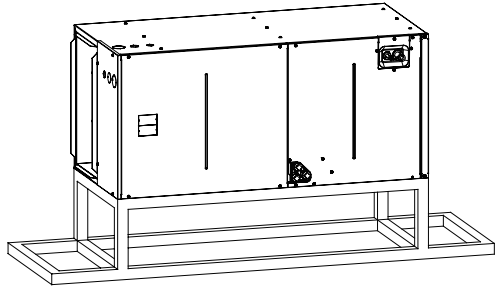

NOTICE:

For horizontal installation, a secondary drain pan (not supplied) is suggested to install under the unit.

Please follow these steps to perform Vertical up installation and Horizontal right installation:

1. Open the upper cover.
2. Open the cover of the electronic control box.
3. Connect the wire according to the wiring diagram.
4. Connect the pipes.
5. Install the drainage pipes.

The unit may be installed in one of the upflow, downflow, horizontal left or horizontal right orientations.

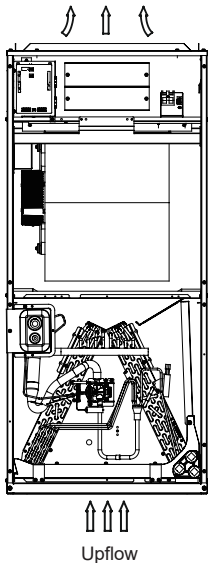

Upflow

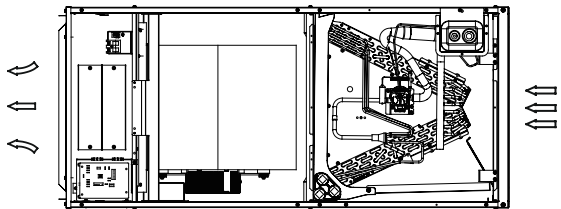

horizontal left flow

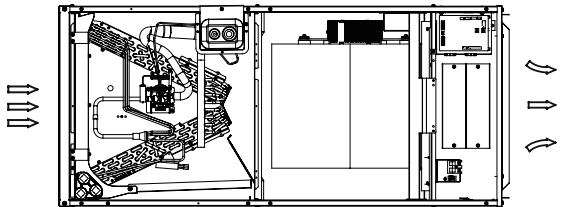

horizontal right flow

NOTE: For a downward air outlet installation, you need to purchase after-sales parts from the dealer and have a professional install them.

Indication of the position of each temperature sensor of the evaporator:

illustrate:

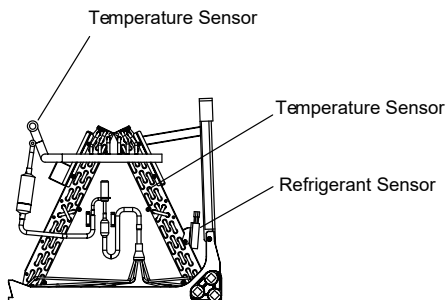

Note: For the horizontal installation, how to disassemble and reinstall the evaporator assembly.

1. Remove the fixed plate of the filter, then take the filter off.

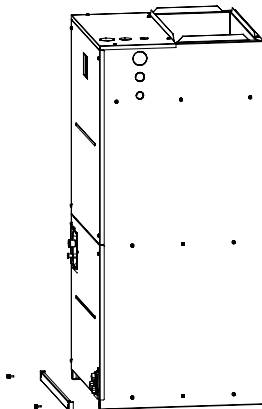

2. Remove the upper cover assembly.

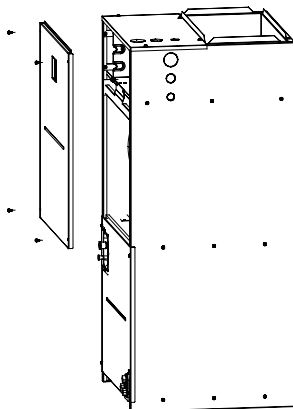

3. Remove evaporator cover plate.

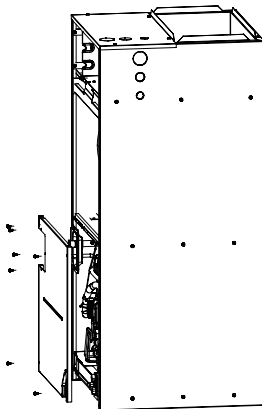

4. Remove the plug of the CN11 refrigerant sensor and the plug of the CN14 temperature sensor.

CN11: Refrigerant Sensor COM.

CN14: Temperature Sensor COM.

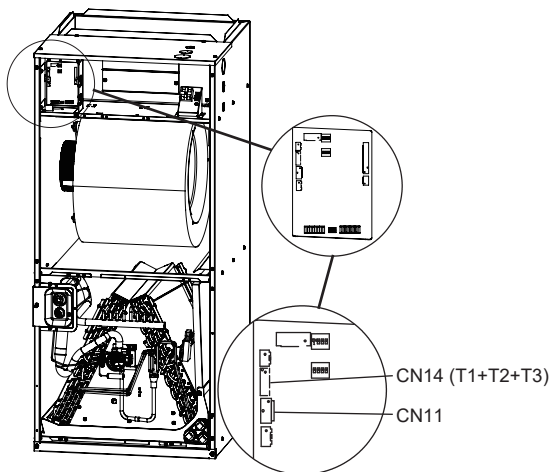

5. Remove CN11 and CN14 cable ties.

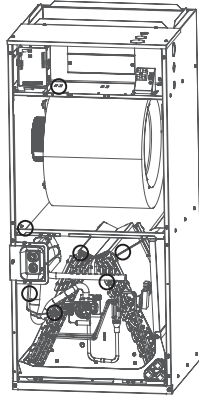

6. Take out the evaporator and drain pan and rotate 180°.

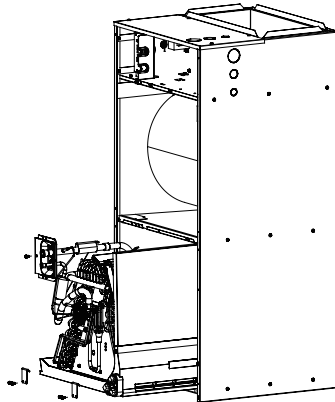

7. Reinstall the evaporator.

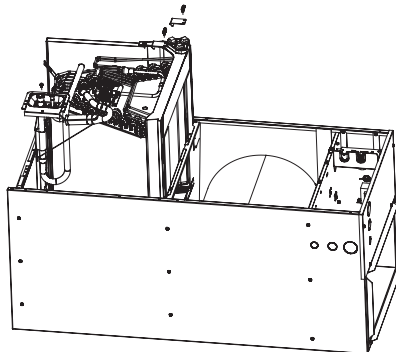

8. Reinstall CN11 and CN14 plug and tie up the sensor wires.

NOTICE: The wire body needs to pass through the wire groove from the water receiving tray and be stuck on the hook of the water receiving tray.

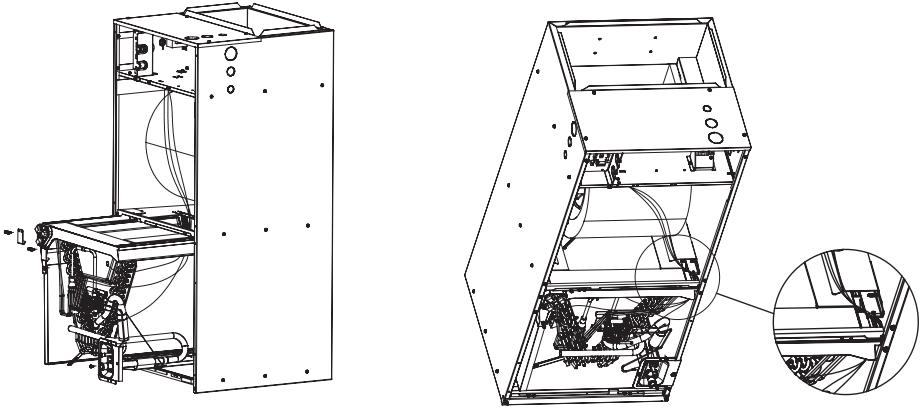

9. Reinstall the drain pan fixed plate and auxiliary support plate.

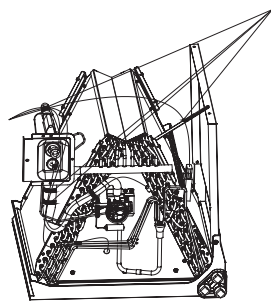
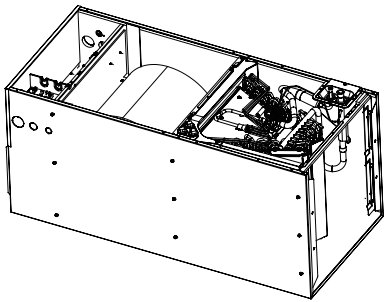

Use cable ties to bind and fix the environmental temperature sensitive bag as shown in the figure.

10. Reinstall evaporator cover plate.

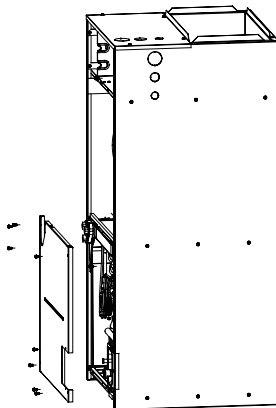

11. Reinstall the upper cover assembly.

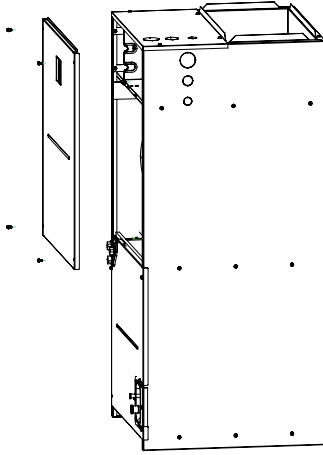

12. Reinstall the filter and filter plate.

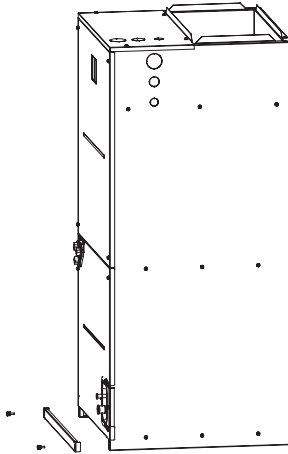

13. Connect the wire according to the wiring diagram.

Refrigerant Piping Connection Instructions

CAUTION

- Do not install the connecting pipe until both indoor and outdoor units have been installed. Insulate both the gas and liquid piping to prevent water leakage.
- Be extra careful not to damage, dent, or deform the pipe while cutting. This will drastically reduce the heating efficiency of the unit.

Cut Pipes

When preparing refrigerant pipes, take extra care to cut and flare them properly. This will ensure efficient operation and minimize the need for future maintenance.

1. Use the piping kit accessory or the pipes purchased locally.
2. Measure the distance between the indoor and the outdoor unit.
3. Cut the pipes a little longer than measured distance.

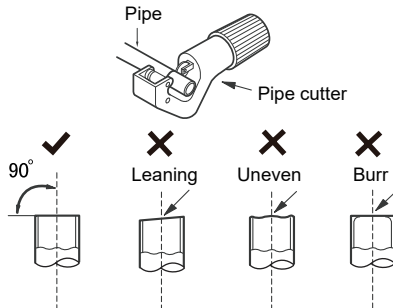

Remove Burrs

Burrs can affect the air-tight seal of refrigerant piping connection. They must be completely removed.

1. Completely remove all burrs from the cut cross section of pipe/tube.
2. Put the end of the copper tube/pipe in a downward direction as you remove burrs in order to avoid dropping burrs into the tubing.

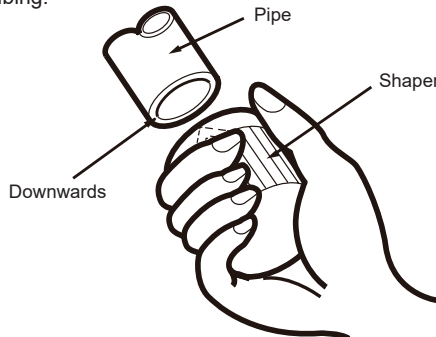

Flaring work

Carry out flaring work using flaring tool as shown below.

Refer to below figures marked with digital number for line brazing procedures. Every figure is corresponding to the following illustrations.

1. Remove caps or plugs. Use a tool to deburr the line ends. Clean both internal and external surfaces of the tubing using an emery cloth.
2. Remove the pressure tap cap from both service valves.
3. Purge the refrigerant lines and indoor coil with dry nitrogen from gas service valve.
4. Wrap a wet rag around the thermal expansion valve temperature sensing package to avoid heat damage and continue the dry nitrogen purge. Braze the refrigerant lines to the service valves. Install a bidirectional filter drier (NO active alumina allowed) in liquid line to protect the heat pump. Do not remove the wet rag until all brazing is completed.
5. If the evaporator's inlet/outlet pipes are equipped with copper caps and plastic quick-connect fittings, first unscrew the plastic quick-connect fittings, release the pressure completely, and then proceed with welding work.

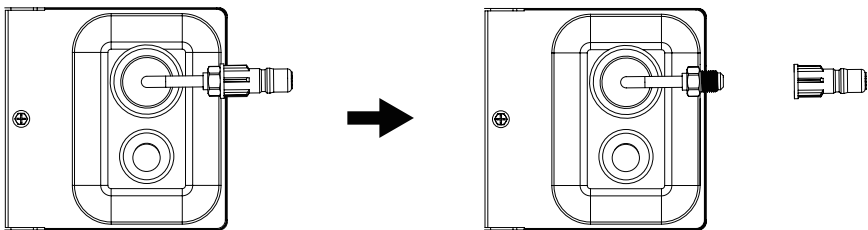

6. Put the pressure tap caps back after the service valves cooled down.

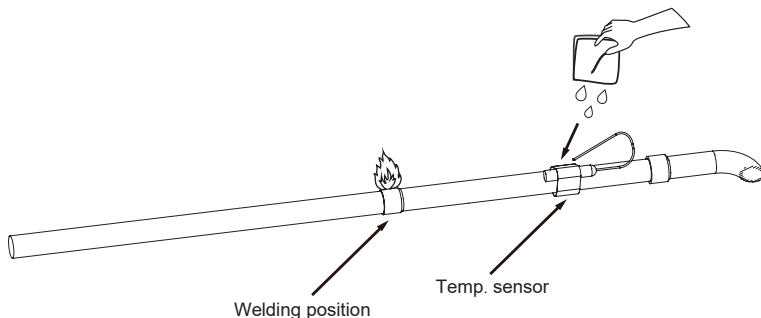

Installation of drainpipe

1. When the air handler is installed vertically, please block the upper drainage hole with a cover.

The lower right of the drainage hole is connected with the drainage pipe, and the lower left of the drainage hole is connected with the overflow pipe that should be exposed to the air; If pipe ① is draining, it means pipe ② is blocked. Contact maintenance personnel as soon as possible.

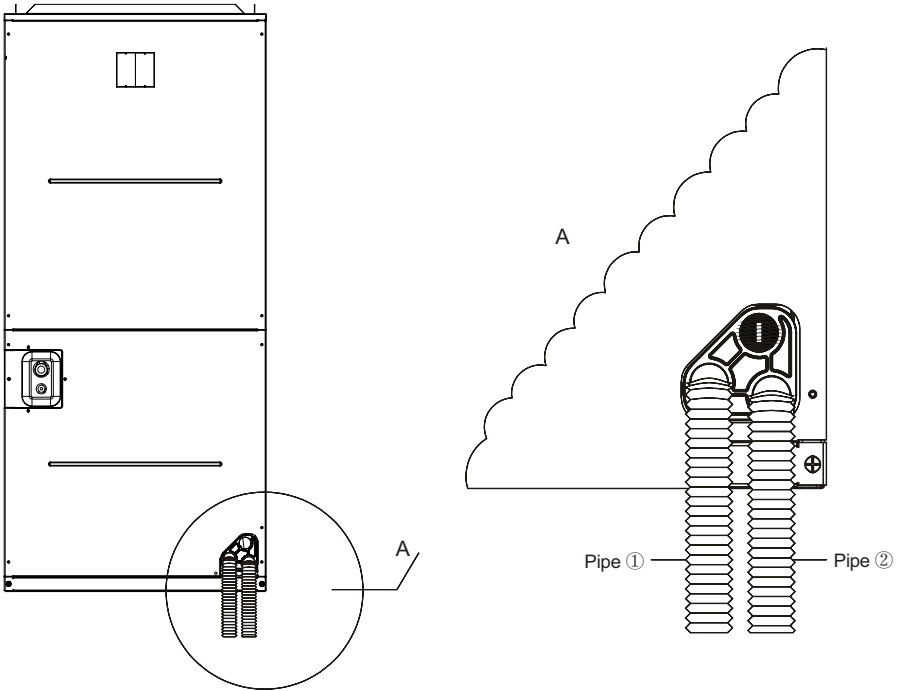

Vertical

2. When installing the air handler lying down, the upper drainage hole is covered, and the lower left of the drainage hole is connected with the drainage pipe, the lower right of the drainage hole is connected with the overflow pipe that should be exposed to the air. If the pipe ① is draining, which means the pipe ② is blocked. Contact maintenance personnel as soon as possible.

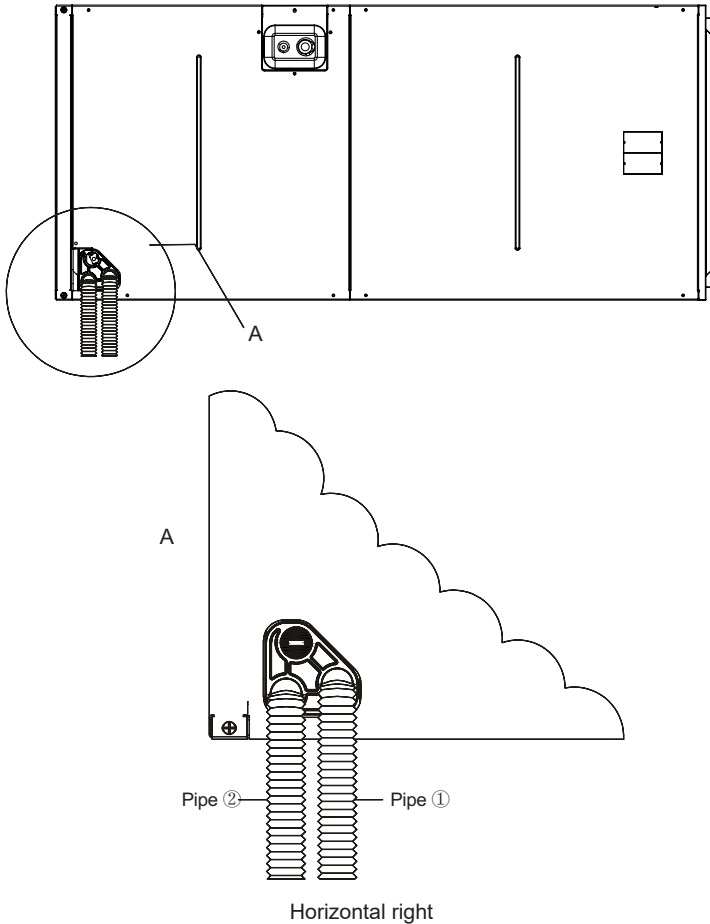

Installation in an unconditioned space

There are two pairs of coil rails in the air handler for default and counter flow application. If the air handler is installed in an unconditioned space, the two unused coil rails should be removed to minimize air handler surface sweating.

The coil rails can be easily removed by taking off the 6 mounting screws from both sides of the cabinet.

Electrical Wiring

Field wiring must comply with the National Electric Code (C.E.C. in Canada) and any applicable local ordinance.

WARNING

Disconnect all power to unit before installing or servicing. More than one disconnect switch may be required to de-energize the equipment. Hazardous voltage can cause severe personal injury or death. Ground the condensing unit according to National, State, and Local code requirements.

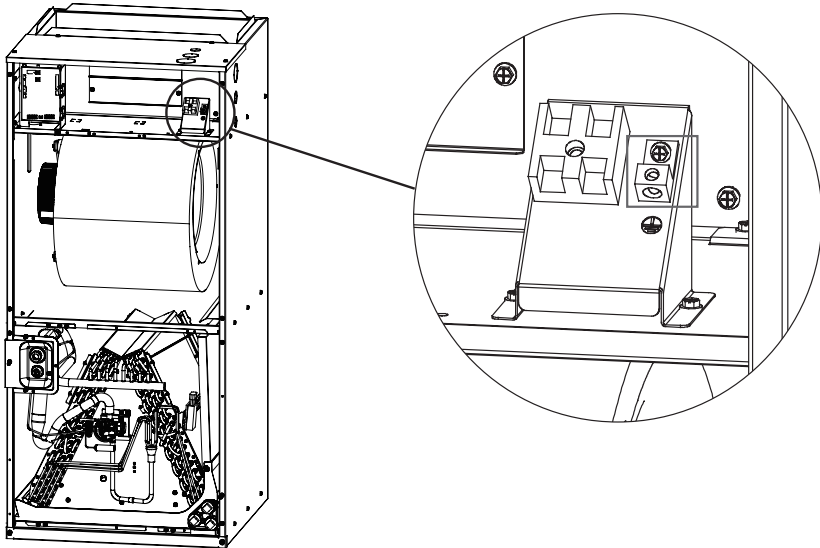

Minimum Cross-Sectional Area of Power and Signal Cables.

| Wiring material ampacities | AWG |
|----------------------------|-----|
| 4 | 22 |
| 7 | 20 |
| 10 | 18 |
| 13 | 16 |
| 18 | 14 |
| 25 | 12 |
| 30 | 10 |
| 40 | 8 |
| 55 | 6 |
| 70 | 4 |

The ampacities shown apply to appliance wiring materials with insulation rated not less than 90°C(194°F).

Supply circuit power wiring must be copper conductors.

Power Wiring

It is important that proper electrical power is available for connection to the unit model being installed.

Refer to the unit nameplate, wiring diagram and electrical data in the installation instructions.

- If required, install a branch circuit disconnect of adequate size, located within sight of, and readily accessible to the unit.
- When the electric heat is installed, units may be equipped with one or two 30~60 amp circuit breakers. These breakers protect the internal wiring in the event of a short circuit and serve as a disconnect. Circuit breakers installed within the unit do not provide over-current protection of the supply wiring and therefore may be sized larger than the branch circuit protection.
- Supply circuit power wiring must be 167 minimum copper conductors at least. Refer to electrical data in this section for ampacity, wire size and circuit protector requirements. Supply circuit protective devices may be either fuses or "HACR" type circuit breakers.

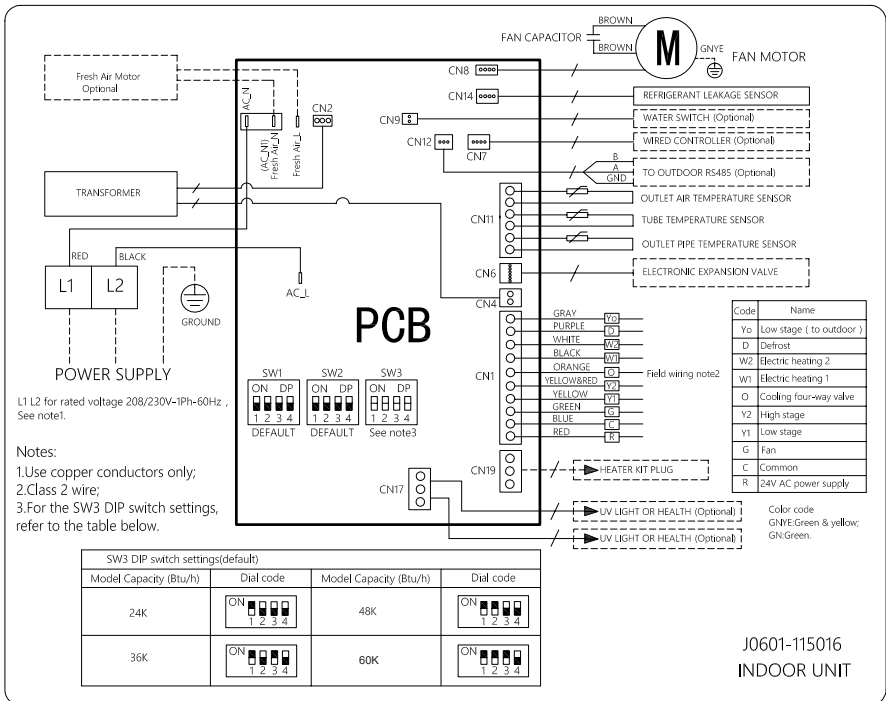

Wiring diagram

Control Wiring

Class 2 low voltage control wiring should not be run in conduit with main power wiring and must be separated from power wiring, unless class 1 wire of proper voltage rating is used.

- Low voltage control wiring should be color-coded 18 AWG.
- Refer to wiring diagrams attached to indoor and outdoor sections to be connected.
- Make sure separation of control wiring and power wiring has been maintained.

2 Stage, 2 Step, Heating Pump

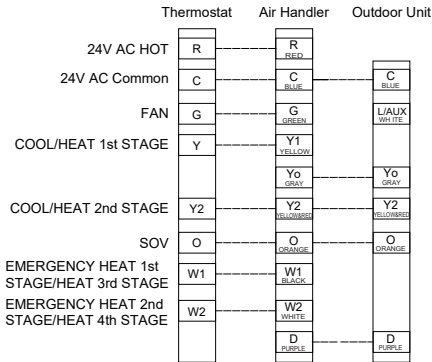

2 Stage, 2 Step, Cooling Only

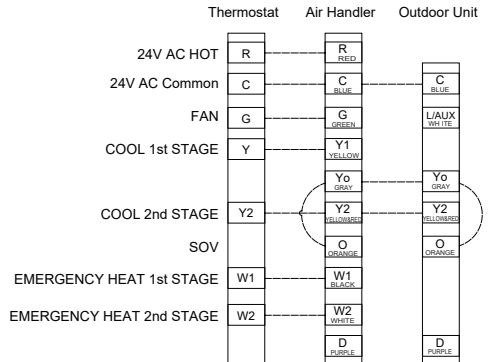

Single Stage, Heating Pump

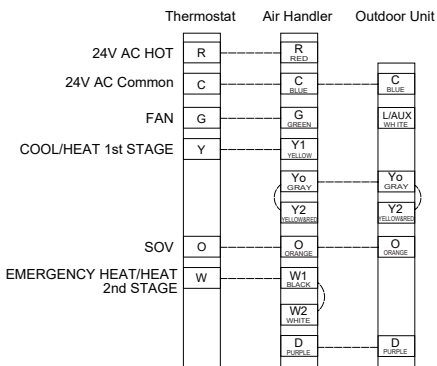

Single Stage, Cooling Only

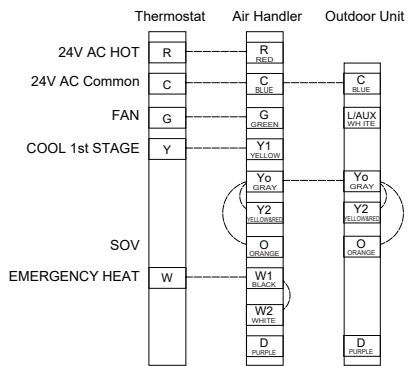

Schematic diagram for control wiring connection

Thermostat terminal definition chart.

| Unit Terminal | Terminal definition |
|---------------|--|
| R | 24 VAC power supply for thermostat from secondary transformer. |
| C | Common wire. |
| G | Fan motor relay. |
| Y1 | Compressor stage 1, low load-output control. |
| Y2 | Compressor stage 2, high load-output control. |
| O | Cooling four-way valve. |
| W1 | Heating stage 1, electrical heater low load-output control. |
| W2 | Heating stage 2, electrical heater high load-output control. |
| Yo | Outdoor Compressor |
| D | Defrost signal (receiving the outdoor unit defrost signal) |

NOTES:

1. Be sure power supply agrees with equipment nameplate.
2. Power wiring and grounding of equipment must comply with local codes.
3. Low voltage wiring to be No. 18 AWG minimum conductor.
4. Some thermostats may use W2/AUX for heat pump.
5. The electrical heater may be not available for some model (need to be checked later).
6. For single stage thermostat with Y/Y1 terminal only, place both Y1 and Y2 wire together to Y/Y1 terminal.
7. When the communication method between the indoor and outdoor units is selected as 24V communication, the above wiring method is required.

Grounding

WARNING

The unit must be grounded.

Failure to do so can result in electrical shock causing personal injury or death.

- Grounding may be accomplished by grounding metal conduit when installed in accordance with electrical codes to the unit cabinet. Grounding may also be accomplished by attaching ground wire(s) to ground lug(s) provided in the unit wiring compartment.
- Use of multiple supply circuits require grounding of each circuit to lug(s) provided in the unit.

Electrical Data

| Model | Voltage-Phase-Hz | The Diameter of the Power Cable Connecting the Terminal Block | Motor HP | Motor Steps | Minimum Circuit AMPS | MAX Overcurrent Protective (A) |
|-------|----------------------|---|----------|-------------|----------------------|--------------------------------|
| 24K | 208/230~ 1Ph-60Hz | 14 | 1/5 | 6 | 5 | 15 |
| 36K | | | 1/3 | | | |
| 48K | | | 1/2 | | | |
| 60K | | | 1/2 | | | |

Airflow Performance

Airflow performance data is based on cooling performance with a coil and no filter in place. Check the table for appropriate unit size selection. External static pressure should stay within the minimum and maximum limits shown in the table below in order to ensure proper airflow.

| Air Handler Model | Motor Speed/ CFM | Available electric auxiliary heater | | | | | | | | | |
|-------------------|------------------|--|--------|--------|--------|--------|--------|--------|--------|--------|--------|
| | | External Static Pressure-Inches W.C. [Psi] | | | | | | | | | |
| | | 0 | 0.1 | 0.16 | 0.2 | 0.3 | 0.4 | 0.5 | 0.6 | 0.7 | 0.8 |
| | | [0] | [.003] | [.005] | [.007] | [.010] | [.014] | [.018] | [.021] | [.025] | [.028] |
| 24K | High | 1388 | 1334 | 1304 | 1294 | 1234 | 1147 | 1077 | 994 | 907 | 783 |
| | Med | 1173 | 1128 | 1089 | 1071 | 999 | 943 | 875 | 807 | 711 | 492 |
| | Low | 826 | 787 | 752 | 738 | 696 | 642 | 545 | 450 | 352 | 271 |
| 36K | High | 1388 | 1358 | 1333 | 1327 | 1297 | 1267 | 1236 | 1206 | 1092 | 978 |
| | Med | 1341 | 1278 | 1236 | 1214 | 1151 | 1087 | 1024 | 960 | 865 | 770 |
| | Low | 1004 | 956 | 922 | 909 | 861 | 813 | 765 | 717 | 644 | 571 |
| 48K | High | 2010 | 1952 | 1912 | 1892 | 1827 | 1756 | 1673 | 1584 | 1468 | 1323 |
| | Med | 1920 | 1842 | 1794 | 1765 | 1688 | 1611 | 1534 | 1457 | 1323 | 1185 |
| | Low | 1576 | 1521 | 1481 | 1462 | 1401 | 1329 | 1246 | 1148 | 1015 | 902 |
| 60K | High | 2010 | 1952 | 1912 | 1892 | 1827 | 1756 | 1673 | 1584 | 1468 | 1323 |
| | Med | 1920 | 1842 | 1794 | 1765 | 1688 | 1611 | 1534 | 1457 | 1323 | 1185 |
| | Low | 1576 | 1521 | 1481 | 1462 | 1401 | 1329 | 1246 | 1148 | 1015 | 902 |

Shaded boxes represent airflow outside the required 300-450cfm/ton at full load.

NOTES: Airflow based upon cooling performance at 230V with no electric heat and no filter. Airflow at 208V is approximately the same as 230V because the multi-tap ECM motor is a constant torque motor. The torque doesn't drop off at the speeds in which the motor operates.

The air distribution system has the greatest effect on airflow. For this reason, the contractor should use only industry-recognized procedures to finish ductwork.

Heat pump systems require a specified airflow. Each ton of cooling requires between 300 and 450 cubic feet per minute (CFM). Duct design and construction should be carefully done. System performance can be lowered dramatically through bad planning or workmanship. Air supply diffusers must be selected and located carefully.

They must be sized and positioned to deliver treated air along the perimeter of the space. Return air grilles must be properly sized to carry air back to the blower as well.

Failure to follow these may cause abnormal noise and drafts.

The installers should balance the air distribution system to ensure proper quiet airflow to all rooms in the home.

This ensures a comfortable living space. An air velocity meter or airflow hood can give a reading of system CFM.

Ductwork

Field ductwork must comply with the National Fire Protection Association NFPA 90A, NFPA 90B and any applicable local ordinance.

WARNING

Do not, under any circumstances, connect return ductwork to any other heat producing device such as fireplace insert, stove, etc. Unauthorized use of such devices may result in fire, carbon monoxide poisoning, explosion, personal injury or property damage.

Sheet metal ductwork run in unconditioned spaces must be insulated and covered with a vapor barrier. Fibrous ductwork may be used if constructed and installed in accordance with SMACNA Construction Standard on Fibrous Glass Ducts. Ductwork must comply with National Fire Protection Association as tested by U/L.

Standard 181 for Class I Air Ducts. Check local codes for requirements on ductwork and insulation.

- Duct system must be designed within the range of external static pressure the unit is designed to operate against. It is important that the system airflow be adequate. Make sure supply and return ductwork, grilles, special filters, accessories, etc. are accounted for in total flow resistance. Refer to the airflow performance table in this manual.
- Design the duct system in accordance with "ACCA" Manual "D" Design for Residential Winter and Summer Air Conditioning and Equipment Selection. Latest editions are available from: "ACCA" Air Conditioning Contractors of America, 1513 16th Street, N.W., Washington, D.C. 20036. If duct system incorporates Xair duct, be sure that the pressure drop information (straight length plus all turns) shown in "ACCA" Manual "D" is accounted for in system.
- Supply plenum is attached to the 3/4" duct flanges supplied with the unit. Attach flanges around the blower outlet.
- Secure the supply and return ductwork to the unit flanges, using proper fasteners for the type of duct used and tape the duct-to-unit joint as required to prevent air leaks.

IMPORTANT

If an elbow is included in the plenum close to the unit, it must not be smaller than the dimensions of the supply duct flange on the unit.

The front flange on the return duct connected to the blower casing must not be screwed into the area where the power wiring is located. Drills or sharp screw points can damage insulation on wires located inside the unit.

Air Filter

Filter application and replacement are critical to airflow, which may affect the heating and cooling system performance. Reduced airflow can shorten the life of the system's major components, such as motor, heat relays, evaporator coil or compressor. Units should be sized for a maximum of 300 feet/ min. air velocity or what is recommended for the filter type installed.

Ensure the air flow is in the range of 300~450CFM if adding high efficiency filters or electronic air filtration systems.

Note that the overall performance and efficiency of the unit will be reduced because of pressure drop by filters.

IMPORTANT

Do not double filter the return air duct.

Do not filter the supply air duct which will change the performance of the unit and reduce airflow.

WARNING

Do not operate the system without filters. A portion of the dust suspended in the air may temporarily lodge in the duct. Any circulated dust particles could be heated and charred by contact with the air handler elements.

This residue could soil ceilings, walls, drapes, carpets and other articles in the house.

Soot damage may occur without filters in place when certain types of candles, oil lamps or standing pilots are burned.

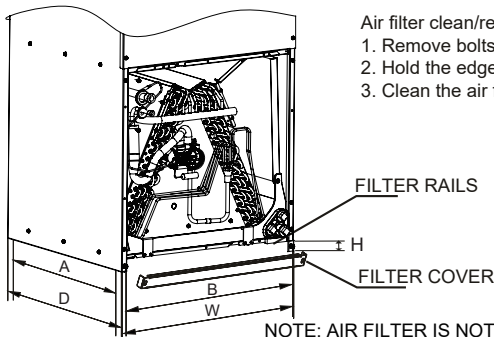

Air filter clean/replacement

1. Remove bolts to take the filter cover away.
2. Hold the edge of the air filter and extract it out.
3. Clean the air filter or use a new one to replace.

NOTE: AIR FILTER IS NOT FACTORY INSTALLED

Filter installation and cleaning

Filter Dimensions

| Model | Dimensions (in.) | | | | | |
|------------|------------------|--------|----|---|----|--------|
| | Filter size | W | D | H | A | B |
| 24K 36K | 18 x 20 | 21 | 21 | 1 | 16 | 19-3/4 |
| 48K 60K | 22 x 20 | 24-1/2 | 21 | 1 | 16 | 23-1/4 |

NOTE:

- Refer to the label on filter cover to install the correct filter size.
- The product is not equipped with a filter.

Refrigerant Sensor

Important Notes:

1. The refrigerant sensor must be maintained by a professional and only the specified sensor by the manufacturer can be replaced.
2. The design life of the refrigerant sensor is 15 years, please replace the sensor within the range of the service life.
3. The refrigerant sensor automatically detects the condition of the machine while in operation, and will automatically start the circulating air flow and stop the compressor when the concentration reaches the alarm range.
4. The alarm signal of the refrigerant sensor is as shown in the following table:

| | 24V communication | 485 communication |
|---|--|-------------------|
| Refrigerant Leak Protection | The red light is steady on | Display "Hd" |
| The communication of the refrigerant sensor is abnormal | The red light blinks once and turns off once | Display "Fd" |

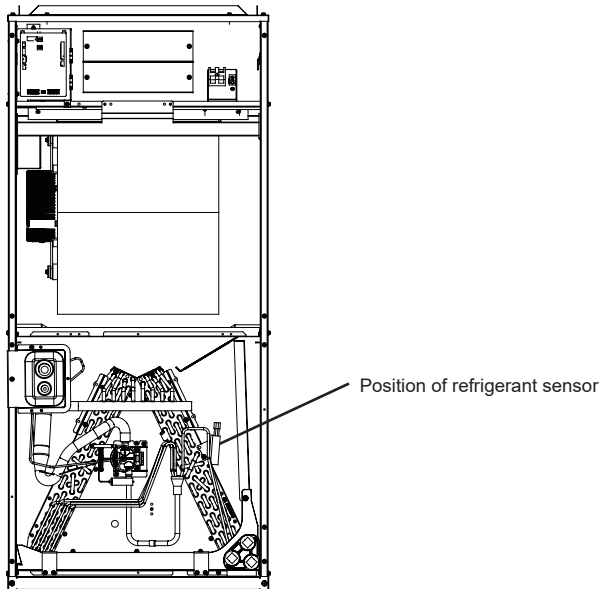

5. The installation position of the refrigerant sensor is shown in the figure below (for example, the appearance of different cabinets may be different).



Internal Function Dip Switch Description

Communication function DIP switch

According to the actual installation requirements, you can choose 24V ON/OFF mode or RS485 communication mode to control the unit.

| Dip bit | Dip code | Function description |
|---------|---|---|
| SW2-1 |  | Factory default, 24V ON/OFF control, using 24V thermostat control unit operation |
| |  | RS485 communication control, the need to purchase wire controllers and communication lines from the manufacturer to meet the use of accessories |

Fan speed adjustment dip switch



STEP 1.

When the SW1_1 is located at the digital end (factory default), the fan runs in 5th level for high speed and 2nd level for low speed. If you want to adjust the fan speed by yourself, you need to change it to the "ON" end:

STEP 2.

Set SW1-1 to "ON" end. Then combining the SW1-2 and SW1-3 to get different fan speeds. The fan speed operation obtained by the combination is shown in the following table:

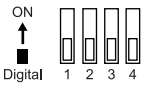
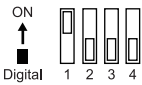
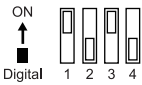
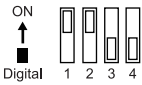
Dip-switch setting for fan speed

| Combination | SW1 setting | Low speed | High speed |
|-------------|---|-----------|------------|
| 1(Default) |  | Med | High |
| 2 |  | Med | High |
| 3 |  | Low | High |
| 4 |  | Low | Med |
| 5 |  | Low | Med |

Note: The DIP switch of SW1 takes effect only when SW2-1 is on the digital end. When the SW2-1 dip switch is ON, the wind gear is directly controlled and adjusted by the wire controller.



Anti-cold draft DIP switch

In 24V ON/OFF control mode, you can use SW1-4 DIP switch to adjust whether the anti-cold air function takes effect.

1. The default DIP switch position of SW1-4 is on the digital end. The cold air protection function takes effect. When the heat pump is started, the unit will first run in accordance with the lower wind gear for a period of time to prevent the cold air from blowing into the room at the initial stage of heating operation and affecting the comfort, and then adjust the speed according to the temperature control wind gear. The unit determines the defrosting status of the outdoor unit according to the signal of terminal D. During the defrosting operation of the outdoor unit, the indoor air conditioner stops running to prevent cold air from blowing into the room during the defrosting process and affecting the comfort. The unit exits the defrosting process and adjusts the rotational speed according to the temperature control air gear after the anti-cold air is finished.

In the electric heating operation state, the unit will control the fan operation according to the temperature control wind gear, and do not perform the anti-cold wind action.

2. You can turn off the anti-cold air function by switching the SW1-4 dip switch to the ON end, and the unit controls the fan operation according to the control wind gear of the thermostat, and does not implement the anti-cold risk control system.

| Dip bit | Dip code | Function description |
|---------|--|---|
| SW1-4 |  | The cold air protection function takes effect |
| |  | The cold air protection function fails |

Note: The DIP switch of SW1 takes effect only when SW2-1 is on the digital end. When the SW2-1 dip switch is located at the ON end, the unit is intelligently controlled and the cold air protection function is always effective.

Dip switch of the lower outlet air gear control function

SW2-2 DIP switches are installed at the digital end by default before delivery. When the unit is installed at the bottom air outlet, adjust the SW2-2 DIP switches to ON. The unit will intelligently control the upper limit of the air gear to prevent the condensate from being blown into the air duct due to excessive air volume.

| Dip bit | Dip code | Function description |
|---------|-------------------------------------|--|
| SW2-2 | <p>ON ↑ ■ Digital 2</p> | The installation form of the unit is dialed to this position when the upper air is discharged or the left and right horizontal air is discharged |
| | <p>ON ↑ ■ Digital 2</p> | The installation form of the unit is dialed to this position when the air is discharged |

Cold Air Prevention

In 24V ON/OFF control mode, you can use SW2-3 DIP switches to adjust whether the exhaust air temperature control function takes effect.

1. The default DIP switch position of SW2-3 is on the digital end, and the exhaust air temperature control function takes effect.

When the unit is running in the heat pump, if the air flow temperature after the heat exchanger is detected to be too high, the electric auxiliary heat will be controlled not to start, to prevent the electric heating temperature from being too high and triggering overheating protection.

2. If you need to further increase the air temperature of the equipment, you can adjust the SW2-3 dip switch position to the ON end, the air temperature control function fails, and the electric heating in this state runs according to the control of the thermostat, which is not affected by the air temperature of the heat pump.

| Dip bit | Dip code | Function description |
|---------|-------------------------------------|---|
| SW2-3 | <p>ON ↑ ■ Digital 3</p> | The exhaust air temperature control function takes effect |
| | <p>ON ↑ ■ Digital 3</p> | The exhaust air temperature control function fails |

Note: In emergency heating mode, when the external unit of the heat pump is not running, the electric heating runs according to the control of the temperature controller, and is not affected by the outlet air temperature of the heat pump.

SW2-4 DIP SWITCHES REMAIN IN FACTORY STATUS

SW2-4 DIP switches remain in factory status (digital end). Do not adjust them at will.

SW3-1 DIP SWITCHES REMAIN IN FACTORY STATUS

SW3-1 DIP switches remain in factory status (ON end). Do not adjust them at will.

SW3-2/ SW3-3/SW3-4 DIP SWITCHES REMAIN IN FACTORY STATUS

SW3-2/ SW3-3/SW3-4 DIP switches remain in factory status (digital end). Do not adjust them at will.

Fault Indication

| code | content | code | content |
|------|---|------|---|
| E0 | Indoor and outdoor communication failure | P8 | Outdoor temperature too high or too low protection |
| E1 | Indoor environment temperature sensor failure | P9 | Compressor drive protection (load abnormality) |
| E2 | Indoor coil temperature sensor failure | PA | Top outlet wind plate communication fault/mode conflict |
| E3 | Outdoor coil temperature sensor failure | F0 | Red exterior motion sensor failure |
| E4 | System abnormalities (low refrigerant) | F1 | Electricity module failure |
| E5 | Model configuration errors | F2 | Exhaust temperature sensor bag failure protection |
| E6 | Indoor PG/DC fan failure | F3 | Outer pipe temperature sensor bag failure protection |
| E7 | Outdoor environment temperature sensor failure | F4 | Refrigerant circuit abnormal protection |
| E8 | Outdoor exhaust temperature sensor failure | F5 | PFC protection |
| E9 | Outdoor IPM module failure/compressor drive failure | F6 | Compressor missing/reverse phase protection |
| EA | Outdoor current sensor failure | F7 | Module temperature protection |
| Eb | Main control board and display screen communication failure | F8 | Four-way valve reversing abnormal protection |
| EC | Outdoor module communication failure | F9 | Module temperature sensing circuit failure |

| | | | |
|----|---|----|--|
| EE | Outdoor EEPROM failure | FA | Compressor phase current detection failure |
| EF | Outdoor DC fan failure | Fb | Refrigeration and heating overload protection |
| EH | Outdoor air intake sensor failure | FC | Reduced frequency power overload protection |
| EP | Outdoor compressor shell top failure | FE | Reduced/frequency module current (compressor phase current) protection |
| EU | Outdoor voltage sensor failure | FF | Reduced/frequency module temperature protection |
| Ej | Outdoor middle coil temperature sensor failure | FH | Reduced/frequency drive protection |
| En | Outdoor air pipe temperature sensor failure | FP | Condensation protection |
| Ey | Outdoor liquid pipe temperature sensor failure | FU | Frost protection |
| P0 | IPM module protection | Fj | Reduced/frequency exhaust protection |
| P1 | Over and under voltage protection | Fn | Reduced/frequency external machine AC current protection |
| P2 | Overcurrent protection | Fy | Reduced/frequency lack of refrigerant protection |
| P3 | Other protections | H1 | High pressure switch failure |
| P4 | Outdoor exhaust temperature too high protection | H2 | Low pressure switch failure |
| P5 | Refrigeration anti-freezing protection | H3 | High pressure sensor failure |
| P6 | Refrigeration anti-overheating protection | H4 | Low pressure sensor failure |
| P7 | Heating anti-overheating protection | Hd | Indoor refrigerant leakage protection |
| dF | Indoor Evaporator Temperature Sensor Fault | C5 | Indoor Unit and Wireless Controller Communication Fault |
| E6 | Indoor DC Fan Motor Fault | EE | Outdoor EEPROM Fault |
| Ed | Indoor EEPROM Fault | d4 | Indoor Condensate Overflow Protection |
| dA | Indoor Discharge Air Temperature Sensor Fault | b5 | Indoor Unit and Fan Drive Board Communication Fault |

Troubleshooting

CAUTION

If one of the following conditions occurs, switch off the power supply immediately and contact your dealer for further assistance:

- The operation light continues to flash rapidly after the unit has been restarted.
- The unit continually trips fuses or circuit breakers.
- A foreign object or water enters the air conditioner.
- The indoor unit leaks.
- Other abnormal situations.

Common Problems

The following symptoms are not a malfunction and in most situations will not require repairs.

| Problem | Possible Cause |
|--|--|
| Abnormal noises of outdoor unit | The unit will make different sounds based on its current operating mode. |
| Both the indoor and outdoor units make noises | The air conditioner may hum during operation. This is a normal phenomenon, which is caused by refrigerant gas flowing through the indoor and outdoor units. |
| | When the air conditioner is turned on, and just stopped or defrosted, a hiss may be heard. This noise is normal and is caused by refrigerant gas stopping or turning. |
| Unit does not turn on when pressing ON/ OFF button | The unit has a 3-minute protection feature that prevents the unit from overloading. The unit cannot be restarted within three minutes of being turned off. |
| | Cooling and Heating Models: If the Operation light and PRE-DEF (Pre-heating / Defrost) indicators are lit up, the outdoor temperature is too cold and the unit's anti-cold wind is activated in order to defrost the unit. |
| The unit changes from COOL mode to FAN mode | The unit changes its setting to prevent frost from forming on the unit. Once the temperature increases, the unit will start operating again. |
| | The set temperature has been reached, at which point the unit turns off the compressor. The unit will resume operating when the temperature fluctuates again. |
| Both the indoor and outdoor units emit white mist | When the unit restarts in HEAT mode after defrosting, white mist may be emitted due to moisture generated from the defrosting process. |
| Dust is emitted from either the indoor or outdoor unit | The unit may accumulate dust during extended periods of nonuse, which will be emitted when the unit is turned on. This can be mitigated by covering the unit during long periods of inactivity. |
| The unit emits a bad odor | The unit may absorb odors from the environment (such as furniture, cooking, cigarettes, etc.) which will be emitted during operations. |
| | The unit filters have become moldy and should be cleaned. |
| The fan of the outdoor unit does not operate | During operation, the fan speed is controlled to optimize product operation. |

Troubleshooting Advice

When troubles occur, please check the following points before contacting a repair company.

| Problem | Possible Cause | Solution |
|--------------------------------------|---|--|
| The unit is not working | Power failure | Wait for the power to be restored |
| | The power switch is off | Turn on the power |
| | The fuse is burned out | Replace the fuse |
| | The unit's 3-minute protection has been activated | Wait three minutes after restarting the unit |
| Poor cooling performance | Temperature setting may be higher than the ambient room temperature | Lower the temperature setting |
| | The heat exchanger on the indoor or outdoor unit is dirty | Clean the affected heat exchanger |
| | The air filter is dirty | Remove the filter and clean it according to instructions |
| | The air inlet or outlet of either unit is blocked | Turn the unit off, remove the obstruction and turn it back on |
| | Doors and windows are open | Make sure that all doors and windows are closed while operating the unit |
| | Excessive heat is generated by sunlight | Close windows and curtains during periods of high heat or bright sunshine |
| | Low refrigerant due to leak or long-term use | Check for leaks, re-seal if necessary and top off refrigerant |
| The unit starts and stops frequently | There's too much or too little refrigerant in the system | Check for leaks and recharge the system with refrigerant |
| | There is air, incompressible gas or foreign material in the refrigeration system. | Evacuate and recharge the system with refrigerant |
| | System circuit is blocked | Determine which circuit is blocked and replace the malfunctioning piece of equipment |
| | The compressor is broken | Replace the compressor |
| | The voltage is too high or too low | Install a voltage stabilizer to regulate the voltage |
| Poor heating performance | The outdoor temperature is lower than 44.5°F | Check for leaks and recharge the system with refrigerant |
| | Cold air is entering through doors and windows | Make sure that all doors and windows are closed during use |
| | Low refrigerant due to leak or long-term use | Check for leaks, re-seal if necessary and top off refrigerant |

Electrical

Electrical Data

| Air Handler Model | Voltage-Phase-Hz | Power Supply Wiring Gauge | Motor HP | Motor Steps | Minimum Circuit AMPS | Fuse (A) |
|-------------------|------------------------------|---------------------------|----------|-------------|----------------------|----------|
| 24K | 208/230/240 ~ 1Ph-60Hz | 14AWG | 1/5 | 6 | 5 | 15 |
| 36K | | | 1/3 | | | |
| 48K | | | 1/2 | | | |
| 60K | | | 1/2 | | | |

NOTE: The parameters in the table do not include electric heating.

Electric Heat Data

| Kit Model | Air Handlers Model | Electric Heat (kW) | MIN. Circuit Ampacity | | | MAX. Fuse or Breaker (HACR) Ampacity | | |
|-----------|--------------------|--------------------|-----------------------|-------|-------|--------------------------------------|-------|-------|
| | | | 208V | 230 V | 240 V | 208V | 230 V | 240 V |
| ATT05KEH | 24K | 5 | 21 | 23 | 24 | 25 | 30 | 30 |
| ATT10KEH | | 10 | 42 | 46 | 48 | 50 | 60 | 60 |
| ATT05KEH | 36K | 5 | 21 | 23 | 24 | 25 | 30 | 30 |
| ATT10KEH | | 10 | 42 | 46 | 48 | 50 | 60 | 60 |
| ATT15KEH | | 5+10 | 21+42 | 23+46 | 24+48 | 25+50 | 30+60 | 30+60 |
| ATT05KEH | 48K | 5 | 21 | 23 | 24 | 25 | 30 | 30 |
| ATT10KEH | | 10 | 42 | 46 | 48 | 50 | 60 | 60 |
| ATT15KEH | | 5+10 | 21+42 | 23+46 | 24+48 | 25+50 | 30+60 | 30+60 |
| ATT05KEH | 60K | 5 | 21 | 23 | 24 | 25 | 30 | 30 |
| ATT10KEH | | 10 | 42 | 46 | 48 | 50 | 60 | 60 |
| ATT15KEH | | 5+10 | 21+42 | 23+46 | 24+48 | 25+50 | 30+60 | 30+60 |

* MCA and Max Fuse Ampacity contains the motor amps.

- Electric heat kits are suitable for air handler multiple position installation.
- means available × means unavailable

Safety Cautions All electric work must be performed by qualified personnel.

ATTKEH** series is designed and approved to be installed in the **IV 18** or TOP AHU.

- Check the **ATT**KEH** label to confirm **ATT**KEH** size based on room load under lowest ambient temperature.
- Inspect all heating elements and whether heater element wires. Contact local distributor immediately if any damage has occurred.

Warning

- Disconnect all external power supplies before performing installation and servicing. Turn off accessory heater power switch if applicable. Failure to do so may cause serious injury.
- ATT**KEH must be properly grounded and use copper supply wires. Make sure to follow national electric code and local regulations.

- When installing it in an enclosed area such as a garage, heater elements should have a minimum clearance of 18" from the floor to ensure proper ventilation.

Available electric auxiliary heater

When unit is installed with electric auxiliary heater, the fan speed selection must meet the following static pressure requirements, and the gray boxes part is not allowed to use electric auxiliary heating.

| Air Handler Model | Motor Speed/ CFM | Available electric auxiliary heater | | | | | | | | | |
|-------------------|------------------|--|--------|--------|--------|--------|--------|--------|--------|--------|--------|
| | | External Static Pressure-Inches W.C. [Psi] | | | | | | | | | |
| | | 0 | 0.1 | 0.16 | 0.2 | 0.3 | 0.4 | 0.5 | 0.6 | 0.7 | 0.8 |
| | | [0] | [.003] | [.005] | [.007] | [.010] | [.014] | [.018] | [.021] | [.025] | [.028] |
| 24K | High | 1388 | 1334 | 1304 | 1294 | 1234 | 1147 | 1077 | 994 | 907 | 783 |
| | Med | 1173 | 1128 | 1089 | 1071 | 999 | 943 | 875 | 807 | 711 | 492 |
| | Low | 826 | 787 | 752 | 738 | 696 | 642 | 545 | 450 | 352 | 271 |
| 36K | High | 1388 | 1358 | 1333 | 1327 | 1297 | 1267 | 1236 | 1206 | 1092 | 978 |
| | Med | 1341 | 1278 | 1236 | 1214 | 1151 | 1087 | 1024 | 960 | 865 | 770 |
| | Low | 1004 | 956 | 922 | 909 | 861 | 813 | 765 | 717 | 644 | 571 |
| 48K | High | 2010 | 1952 | 1912 | 1892 | 1827 | 1756 | 1673 | 1584 | 1468 | 1323 |
| | Med | 1920 | 1842 | 1794 | 1765 | 1688 | 1611 | 1534 | 1457 | 1323 | 1185 |
| | Low | 1576 | 1521 | 1481 | 1462 | 1401 | 1329 | 1246 | 1148 | 1015 | 902 |
| 60K | High | 2010 | 1952 | 1912 | 1892 | 1827 | 1756 | 1673 | 1584 | 1468 | 1323 |
| | Med | 1920 | 1842 | 1794 | 1765 | 1688 | 1611 | 1534 | 1457 | 1323 | 1185 |
| | Low | 1576 | 1521 | 1481 | 1462 | 1401 | 1329 | 1246 | 1148 | 1015 | 902 |

INSTALLATION INSTRUCTIONS

"ATT**KEH" Electric Heater Kits For use in Air Handlers ATTENTION

INSTALLING PERSONNEL

Prior to installation, thoroughly familiarize yourself with this installation manual.

Observe all safety warnings. During installation or repair, caution is to be observed. It is your responsibility to install the product safely and to educate the customer on its safe use.

1. Unfasten 4 screws to take away the blower access panel of the air handler.



2. Remove the cover plate from the air handler.

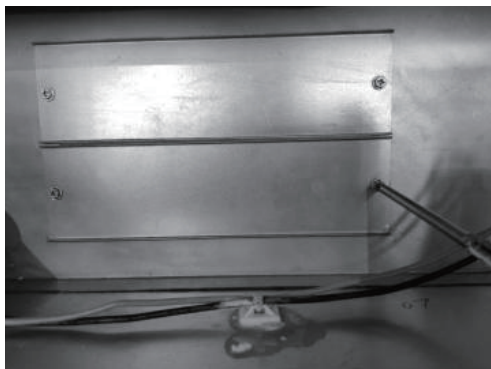

3. Slide the heater kit into the slot and secure element plate with previously removed screws.

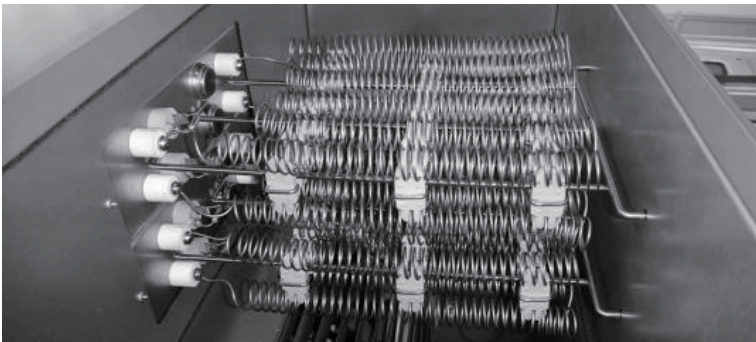
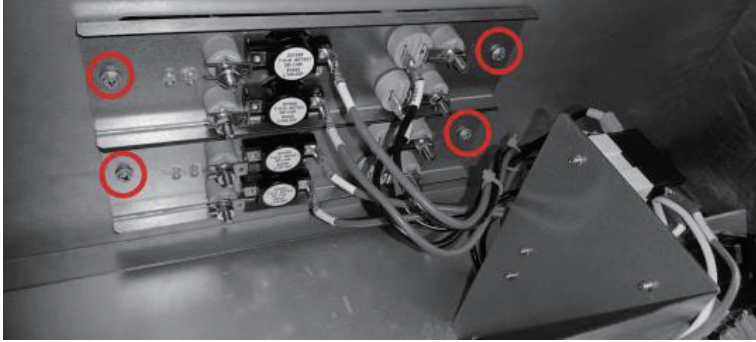

When sliding the heater kit into the slot ensure that it is installed in the correct orientation described below. Thermostat will be on the left hand side and the fuse will be on the right hand side.

When two elements are being used ensure that "UPPER" and "LOWER" elements are installed in the correct slots and orientations.

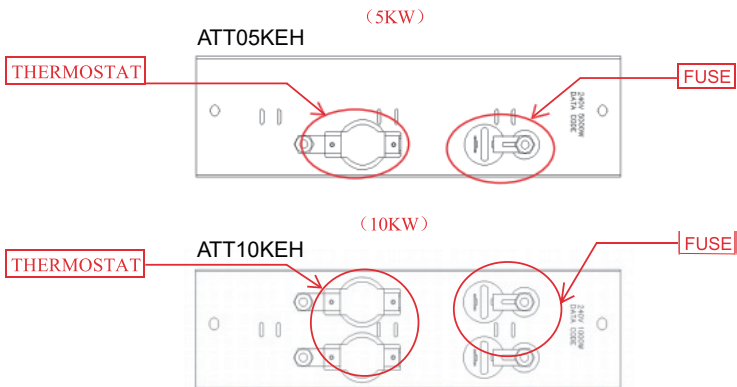

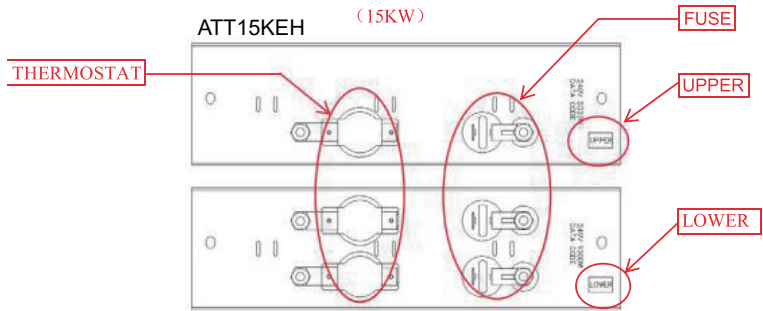

4. Align the attachment clip and the hole and fasten the loose wires by using wire tie.

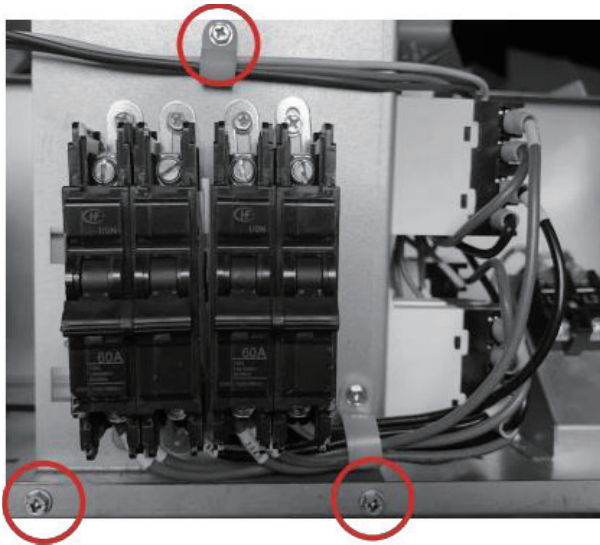

5. Install the circuit breaker into the mounting rail, break out appropriate area of the plastic circuit breaker cover on the access panel of the air handler.

CONNECT
TO 3PINS

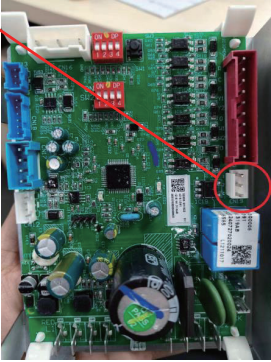

CHECK SCREWS

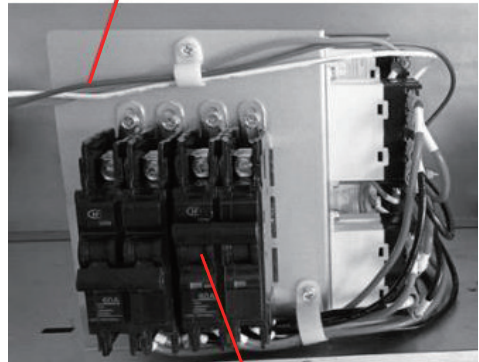

CHECK SCREWS

6. The labels for the circuit diagram of the electric heater are to be pasted in this area.

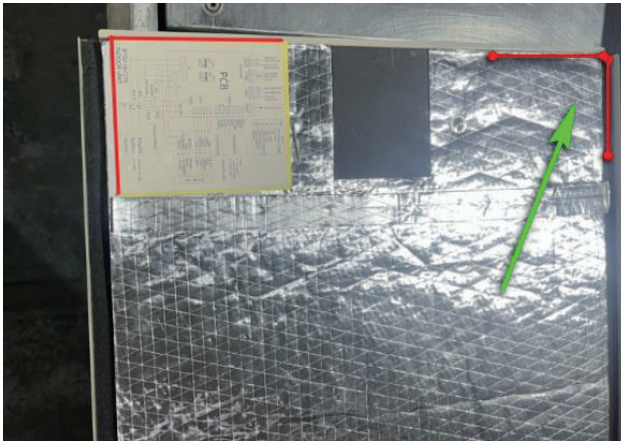

WARNING:

FIRE, ELECTRICAL SHOCK, HAZARD

After connecting all wires, check all screws of breaker and make sure all screws are properly tight. Failure to do so will result in breaker malfunction, fire, death, personal injury and property damage.

NOTE:

- When indoor control board receives W1/W2 signal, electric heater will be energized and indoor blower will be turned on.
- When W1/W2 signal is off, indoor blower will be turned off.
- Blower motor runs when "c" is energized, and off when "c" is de-energized.

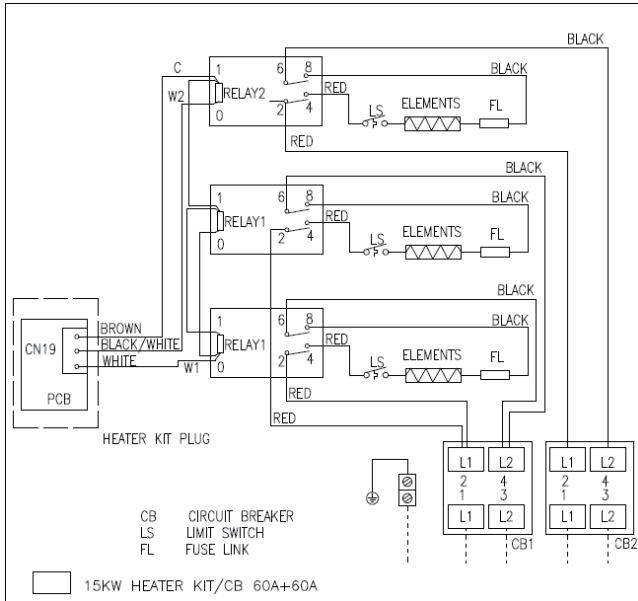

Wiring diagram for 15KW electric heat

Disposal Guideline

- 1) Minimum installation height, minimum room area (operating or storage) refer to installation manual.
- 1) La taille minimale d'installation, la surface minimale de pièce (opération ou stockage) se réfèrent au manuel d'installation.
- 2) Risk of fire-auxiliary devices which may be ignition sources shall not be installed in the ductwork, other than auxiliary devices listed for use with the specific appliance. See instructions.
- 2) Risque d'incendie-l'équipement auxiliaire qui peut être une source d'inflammation ne doit pas être installé dans le système de tuyauterie, à l'exception de l'équipement auxiliaire utilisé avec un équipement spécifique. Voir les instructions.
- 3) Mount with the lowest moving parts at least 2.5m (8.2ft) above floor or grade level.
- 3) Installé avec la partie mobile la plus basse au moins 2.5m (8.2ft) au-dessus du sol ou du plan du sol.
- 4) Risk of electric shock. Can cause injury or death. Disconnect all remote electric power supplies before servicing.
- 4) Risque de choc électrique. Causer des blessures ou la mort. Avant la réparation, débranchez toute alimentation à distance.
- 5) Risk of fire. Flammable refrigerant used. To be repaired only by trained service personnel. Do not puncture refrigerant tubing.
- 5) Risque d'incendie. Utilisation de réfrigérants inflammables. L'entretien ne peut être effectué que par un personnel de maintenance formé. Ne pas percer la ligne de réfrigérant.
- 6) Risk of fire. Dispose of properly in accordance with federal or local regulations. Flammable refrigerant used.
- 6) Risque d'incendie. Disposer correctement conformément à la réglementation fédérale ou locale. Utilisation de réfrigérants inflammables.
- 7) Risk of fire. Flammable refrigerant used. Consult repair manual/owner's guide before attempting to service this product. All safety precautions must be followed.
- 7) Risque d'incendie. Utilisation de réfrigérants inflammables. Veuillez consulter le manuel de réparation/guide de l'utilisateur avant d'essayer de réparer ce produit. Toutes les précautions de sécurité doivent être respectées.
- 8) Risk of fire. Due to flammable refrigerant used. Follow handling instructions carefully in compliance with national regulations.
- 8) Risque d'incendie causé par l'utilisation de réfrigérants inflammables. Suivez attentivement les instructions de manutention conformément aux réglementations nationales.
- 9) Warning: Before accessing the terminals, all power supply circuits must be disconnected.
- 9) Avertissement: Avant d'accéder aux bornes de raccordement, tous les circuits d'alimentation doivent être déconnectés.





Intertek

The AHRI Certified mark indicates company participation in the AHRI Certification program. For verification of individual certified products, go to ahridirectory.org.

The manufacturer has a policy of continuous data improvement and it reserves the right to change design and specifications without notice. We are committed to using environmentally conscious print practices.