



Submittal Data Sheet

Indoor Unit Model#: ACiQ-30-AHD
Outdoor Unit Model#: ACiQ-30-HPD

Air Handler Heat Pump System

Location:	Approval:
Engineer:	Date:
Submitted to:	Construction:
Submitted by:	Unit #:
Reference:	Drawing #:



INDOOR UNIT SPECIFICATIONS		
ESP (in.W.G)		0-0.8
Indoor Air Flow (Turbo/H/M/L/Si) (CFM)		988.8 / 894.7 / 806.4 / 712.2 / N/A
Indoor Noise Level (Turbo/H/M/L/Si) (dBA)		47.0 / 46.0 / 43.0 / 27.5 / N/A
Dimension (W×D×H)	inch	21.02 × 21.02 × 49.02
	mm	534.0 × 534.0 × 1245.0
Package (W×D×H)	inch	26.57 × 24.41 × 52.56
	mm	675 × 620 × 1335
Net/Gross Weight	lbs	128.97 / 153.44
	kg	58.5 / 69.6

OUTDOOR UNIT SPECIFICATIONS		
Compressor Type		ROTARY
Compressor Model		MTH356UKRC8FQL
Refrigerant		R454B
Refrigerant Oil Charge (mL)		1300
Refrigerant Oil		HAF68D1A
Outdoor Air Flow (Max) (CFM)		3001.8
Outdoor Noise Level (dBA)		60.5
Dimension (W×D×H)	inch	37.24 × 16.14 × 31.89
	mm	946.0 × 410.0 × 810.0
Package (W×D×H)	inch	42.91 × 19.68 × 34.84
	mm	1090 × 500 × 885
Net/Gross Weight	lbs	164.02 / 174.60
	kg	74.4 / 79.2

EFFICIENCY RATINGS			
Cooling		Heating	
SEER2	16.8	HSPF2-4	10.0
EER2	11.7	COP	3.65

COOLING PERFORMANCE	
Cooling (Btu/hr)	
Rated Capacity	30000
Min/Max Capacity	12800~39000
Moisture Removal (L/h)	2.77
Standard Operating Range °F (°C)	-22~122 (-30~50)
Rated Cooling Conditions:	Indoor: 80°F DB/67°F WB Outdoor: 95°F DB/75°F WB

HEATING PERFORMANCE	
Heating (Btu/hr)	
1. @ 47°F Rated	34000
1. @ 47°F Min/Max Capacity	10300~38500
2. @ 17°F Rated	23800
3. @ 5°F Rated: Capacity / COP	32600 / 1.96
3. @ 5°F Max: Capacity	32600
Standard Operating Range °F (°C)	-22~75 (-30~24)
1. Rated Heating Conditions:	Indoor: 70°F DB/60°F WB Outdoor: 47°F DB/43°F WB
2. Rated Heating Conditions:	Indoor: 70°F DB/60°F WB Outdoor: 17°F DB/15°F WB
3. Heating Conditions, Compressor Operating at Max. Frequency	Indoor: 70°F DB/60°F WB Outdoor: 5°F DB/5°F WB

ELECTRICAL SPECIFICATIONS	
Indoor Power Supply	115/208/230V, 60Hz, 1Ph
Indoor MCA 115V / (208/230V)	8.0 / 6.0
Indoor MOP	15
Outdoor Power Supply	208/230V, 60Hz, 1Ph
Outdoor MCA	29.5
Outdoor MOP	30
Communication Wiring	AWG 20-2
Compressor RLA	22.4
Outdoor Fan Motor RLA	1.5
Outdoor Fan Motor W	120
Indoor Fan Motor RLA	4.5
Indoor Fan Motor W	375
System Power Input @ Cooling (W)	2567 (850 ~ 3620)
System Power Input @ Heating (W)	2790 (655 ~ 3020)
MCA: Min. circuit amps (A)	MOCP: Max. over current protection (A)
RLA: Rated load amps (A)	W: Fan motor rated output (W)

REFRIGERANT PIPING SPECIFICATIONS	
Throttle type (Indoor)	EXV
Throttle type (Outdoor)	EXV
Liquid Size	9.52mm (3/8in)
Gas Size	19mm (3/4in)
Max. Piping Length (ft/m)	164 / 50
Max. Height Difference (ft/m)	82 / 25
Max. Pre-charged Length (ft/m)	24.6 / 7.5
Refrigerant Pre-charged Amount (oz/kg)	105.82 / 3
Additional Refrigerant Charge (oz/ft) / (g/m)	0.7 / 65
Connection Method	Flared

Indoor Unit Dimensions

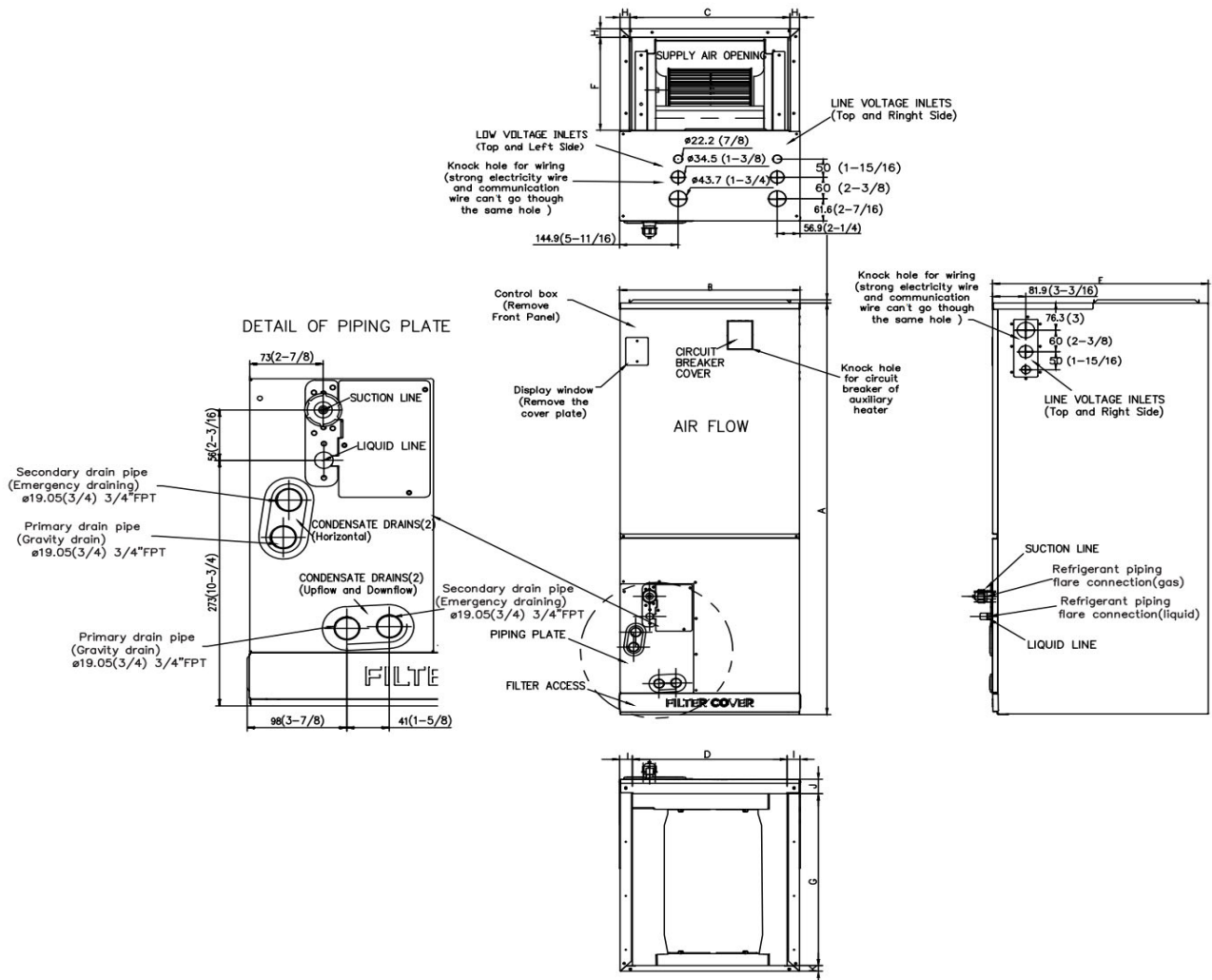

Dimensions	Model	18k/24k		30k/36k		42k/48k/60k	
		inch	mm	inch	mm	inch	mm
A	Model Height	45	1143	49	1245	53	1346
B	Model Width	17-1/2	445	21	534	24-1/2	622
C	Supply Air Opening Width	15-5/8	397	19-1/8	486	22-5/8	575
D	Return Air Opening Width	15-1/8	384	18-5/8	473	22-1/8	562
E	Model Depth	21	534	21	534	21	534
F	Supply Air Opening Depth	10-1/4	260	10-1/4	260	10-1/4	260
G	Return Air Opening Depth	18-3/4	476	18-3/4	476	18-3/4	476
H	Supply Air Opening Clearance	15/16	24	15/16	24	15/16	24
I	Return Air Opening Side Clearance	1-1/4	32	1-1/4	32	1-1/8	28
J	Return Air Opening Front Clearance	1-1/2	38	1-5/8	41	1-5/8	41
K	Return Air Opening Back Clearance	5/8	16	5/8	16	3/4	19

Outdoor Unit Dimensions

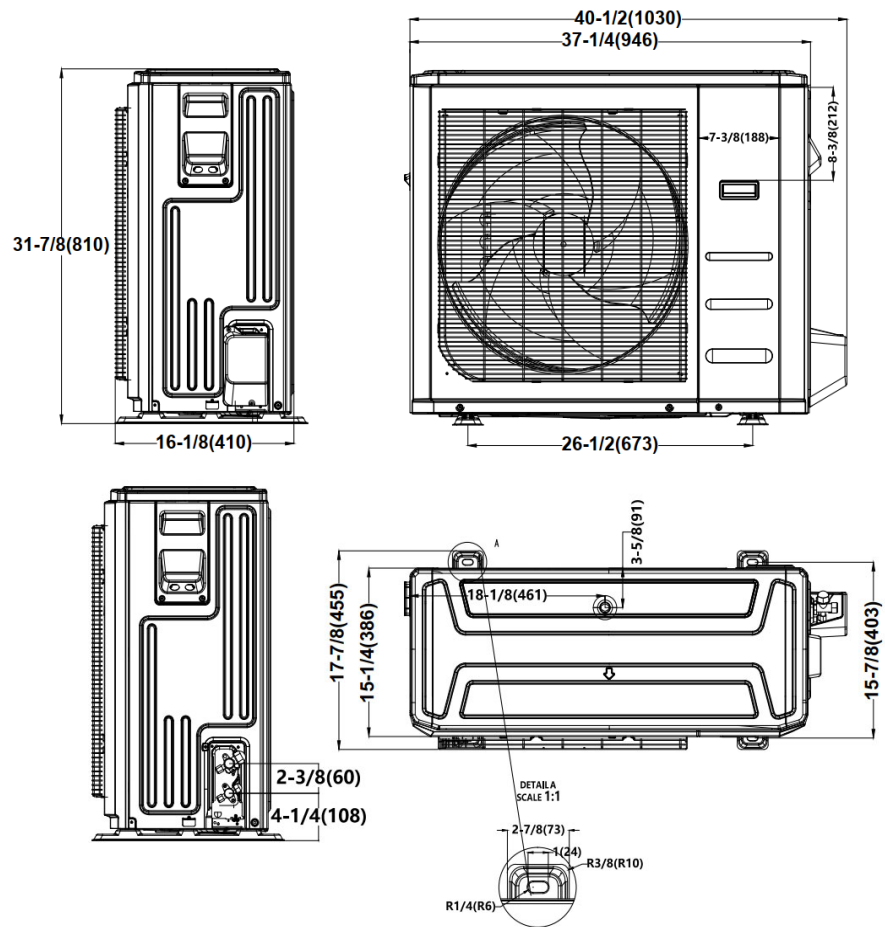

Installation Instructions For Outdoor Unit

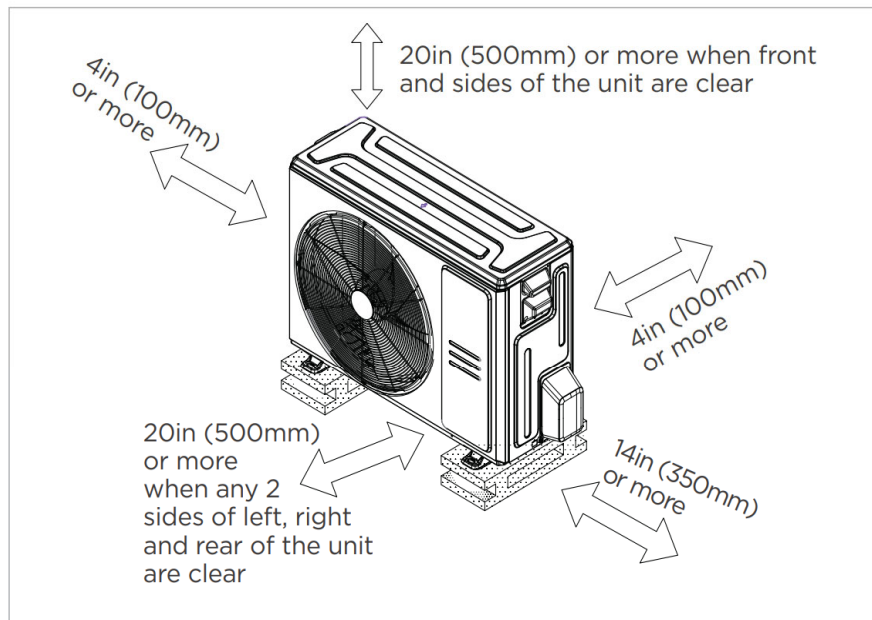

Meets all spatial requirements shown in Installation Clearance Requirements above.

Fan Performance For Indoor Unit

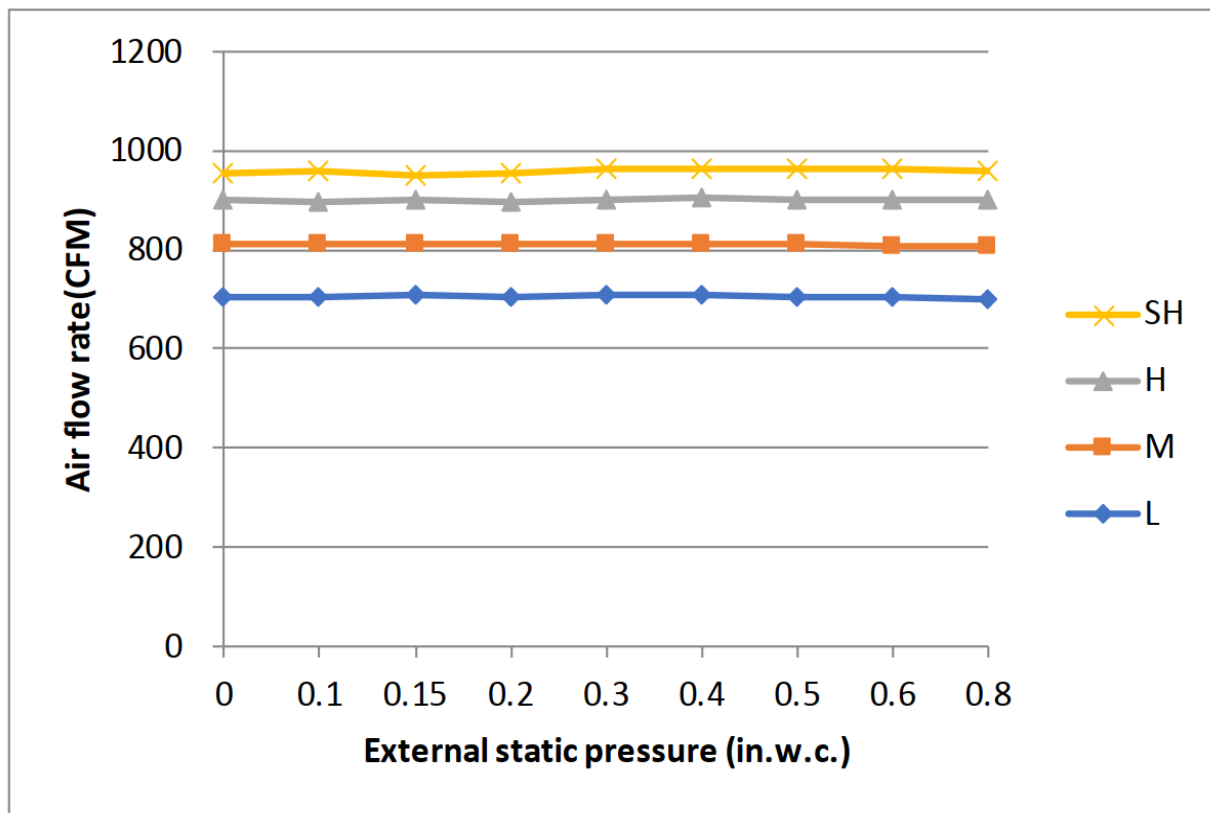

Features

- Multi-position installation: horizontal (left or right), vertical (up or down)
- Aluminum Coil
- Constantly Air Flow system up to 0.80 In.W.G
- 1 inch R4.2 fiberglass free insulation reduces condensation and boosts efficiency (optional)
- Optional Auxiliary heat kit up to 25kW
- Easy Maintenance
- Multiple control options available:
 - Two way communication wired controller:120N(X6)
 - Two way communication wired controller with built-in WiFi:120N(X6W)
 - Wireless remote controller
 - Third-Party 24V Thermostat
- Adaptive Control System
- High efficiency up to 19 SEER2, 12.5 EER2, 10.3 HSPF2
- 100% heat output at -4F*
- Chassis heater and crankcase heater equipped as standard

* For 36K model, rated cooling capacity/heating capacity at -4F=100%