



## 24K-60K R32 DC-INVERTER ROOFTOP PACKAGE UNIT HEAT PUMP

# INSTALLATION & OWNER'S MANUAL

### Models Covered:

AC-I-24-INV-HP-PKG

AC-I-36-INV-HP-PKG

AC-I-48-INV-HP-PKG

AC-I-60-INV-HP-PKG

AC-I-60-INV-HP-3PH-PKG



**WARNING: DO NOT destroy or lose this manual. Please read the manual thoroughly. Also, store the manual in a place that allows for easy retrieval and future reference. As a result of continuous product improvement, the specification and design of this product are subject to change without advanced notice. Consult your manufacturer or your dealer for further details regarding this product. The images and illustrations within this manual are for reference only. The actual shape and size of your product may vary.**

**VERSION DATE: 05-28-26**

# CONTENTS

1. Symbol and Key to Safety Instructions.....	01
2. Dimensions.....	10
3. Installation.....	16
4. Airflow Performance.....	20
5. Indoor Fan Motor Function.....	23
6. Ductwork.....	24
7. Condensate Drain Connection.....	25
8. Air Filter (Not Factory-Installed).....	26
9. Electrical Wiring.....	27
10. Start Up.....	31
11. System Charge Adjustment.....	32
12. Refrigerant Charge and Room Area Limitations.....	36
13. Replace the refrigerant concentration sensor.....	40
14. System Operation and Troubleshooting.....	41
15. Wiring Diagram.....	54
16. Cleaning and Maintenance.....	57

# 1. Symbol and Key to Safety Instructions

## 1.1 Symbol Keywords



### WARNING

The warnings in this document are identified by warning triangles printed on a black background. The key words at the beginning of the warning indicate the type and severity of the next risk if no measures are taken to prevent it.

The following keywords are defined and used in this document:



### Danger

Indicates a hazardous situation, which, if not avoided, will lead to death or serious injury.



### Warning

Indicates a hazardous situation, which, if not avoided, may lead to death or serious injury.



### Caution

Indicates a hazardous situation, which, if not avoided, may cause mild to moderate injury.



### Note

Used to deal with behaviors unrelated to personal injury.

## Important information



This symbol represents important information that is not dangerous to people or property.

## 1.2 Safety

Please Read Before Continuing.



### WARNING

- ▶ Failure to observe this warning may result in property damage, serious personal injury or death.
- ▶ Before touching the electrical components, wait for 3 minutes after disconnecting the power supply.



### NOTICE

- ▶ This document is the property of the customer and is kept by this unit. When you are finished, please return to the service information package.
- ▶ These instructions do not cover all changes in the system, nor do they provide all unexpected situations that may be encountered during installation.
- ▶ If you need more information, or there are special problems that are not sufficient for the buyer, you should consult your installation dealer or local dealer.



Some benefits of installing an approved indoor and outdoor split system are maximum efficiency, best performance and best overall system reliability.



This document contains wiring diagram and maintenance information. This is the customer's property and belongs to this unit. When you are finished, please return to the service information package.

---

### Warning:

- The unit must be installed by qualified personnel with a capability certificated for handling refrigerant fluids. Refer to regulation and laws in use on installation location.
- Installation, service, maintenance and repair of this unit must be performed by a certified technician.
- Servicing shall be performed only as recommended by the manufacturer.
- Product uninstallation and recycling must be performed by a certified technician.
- The appliances is designed to be operated in outdoor area. If have to be installed indoor, the appliance shall be stored in a room without continuously operating open flames (for example an operating gas appliance) and ignition sources (for example an operating electric heater).
- This appliance is not intended for use by persons (including children) with reduced physical, sensory or mental capabilities, or lack of experience and knowledge, unless they have been given supervision or instruction concerning use of the appliance by a person responsible for their safety.
- The appliance shall be installed in accordance with national wiring regulations.
- Children should be supervised to ensure that they do not play with the appliance.
- Before accessing the connection terminals, all power circuits must be disconnected.
- This information is intended for use by individuals with sufficient electrical and mechanical experience background. Attempting to repair central air conditioning products may result in personal injury and/or property damage.



---

### Warning: Dangerous voltage

- Failure to observe this warning may result in property damage, serious personal injury or death.
- Can cause injury or death. disconnect all remote electric power supplies before servicing. Follow proper locking/tagging procedures to ensure that the power supply will not be energized accidentally.



---

### Warning: Refrigerant oil

- Attempting to repair central air-conditioning products may result in property damage, serious personal injury or death. These units use R32 refrigerant, and its working pressure is 50-70% higher than R-22. Use only the service equipment approved by R32. The refrigerant cylinder is painted "rose" to indicate the type of refrigerant, and may contain a "dip" tube to allow liquid refrigerant to be filled into the system. This systems use POE oil (VG74, VG75 or equivalent), which can easily absorb moisture from the atmosphere. In order to limit this "moisture absorption" effect, the system should be sealed as much as possible. If the system is exposed to the atmosphere for more than 4 hours, the compressor oil must be changed. Do not destroy the vacuum with air, and always replace the filter dryer when you open the system for component replacement.





### Warning: Hot surface

- May cause mild to severe burns. Failure to observe this caution may result in property damage or personal injury. Do not touch the top of the compressor.
- 



### Caution: Contains refrigerant

- Failure to follow the correct procedures will lead to personal illness or injury or serious equipment damage. The system contains high-pressure oil and refrigerant. Before opening the system, recover the refrigerant to release the pressure.
- 



### Note: Grounding required

- Failure to check or use the correct maintenance tools may result in equipment damage or personal injury. Reconnect all grounding devices. All parts of this product that can conduct current are grounded. If the grounding wire, screw, strap, clip, nut or washer used to complete the grounding path is removed during maintenance, it must be put back in place and properly fixed.
- 



### Warning: Brazing required

- Failure to check the wiring or use the correct maintenance tools may result in equipment damage or personal injury. If using existing refrigerant lines, make sure that all joints are brazed, not soldered.
- 



### Warning: High current leakage

- Failure to observe this warning may result in property damage, serious personal injury or death. Before connecting the power supply, grounding is essential.
- 



### Warning:

- This product may expose you to chemicals including lead and lead components, which are known to cause cancer, birth defects or other reproductive harm in California. For more information, please visit [www.P65Warnings.ca.gov](http://www.P65Warnings.ca.gov).
- 







### Warning:

- Do not use means to accelerate the defrosting process or to clean, other than those recommended by the manufacturer.
  - The appliances is designed to be operated in outdoor area. If have to be installed indoor, the appliance shall be stored in a room without continuously operating ignition sources (for example: open flames, an operating gas appliance or an operating electric heater.)
  - Do not pierce or burn.
  - Be aware that refrigerants may not contain an odour.
-

For appliances using FLAMMABLE REFRIGERANTS with safety features that depend upon the proper function of a leak detection system used for leak mitigation, the instructions and unit markings shall contain the substance of the following:

"LEAK DETECTION SYSTEM installed. Unit must be powered except for service." If any remote located REFRIGERANT SENSOR is employed to detect leaked refrigerant, such a remote located REFRIGERANT SENSOR shall also apply to this marking or be accompanied by such instructions.

**Explanation of symbols displayed on the unit**

	<b>WARNING</b>	This symbol that this appliance used a flammable refrigerant . If the refrigerant is leaked and exposed to an external ignition source, there is a risk of fire.
	<b>WARNING</b>	This symbol shows that appliance shall be installed, operated and stored in a room with a floor area not less than the minimum room area.
	<b>CAUTION</b>	This symbol that the operation manual should be read carefully.
	<b>CAUTION</b>	This symbol that a service personnel should be handling this equipment with reference to the installation manual.
	<b>CAUTION</b>	This symbol that information is available such as the operating manual or installation manual.

**1.3 Safety precautions for R32 refrigerant**

**WARNING**

- Do not use means to accelerate the defrosting process or to clean, other than those recommended by the manufacturer.
- The appliance shall be stored in a room without continuously operating ignition sources (for example: open flames, an operating gas appliance or an operating electric heater).
- Do not pierce or burn.
- Be aware that refrigerants may not contain an odour.

**Qualification of workers**

Every working procedure like maintenance, service and repair operations that affects safety means shall only be carried out by competent persons.

Examples for such working procedures are:

- Breaking into the refrigerating circuit;
- Opening of sealed components;
- Opening of ventilated enclosures.

**Checks to the area**

Prior to beginning work on systems containing FLAMMABLE REFRIGERANTS, safety checks are necessary to ensure that the risk of ignition is minimised.

**Work procedure**

Work shall be undertaken under a controlled procedure so as to minimise the risk of a flammable gas or vapour being present while the work is being performed.

## **General work area**

All maintenance staff and others working in the local area shall be instructed on the nature of work being carried out. Work in confined spaces shall be avoided.

## **Checking for presence of refrigerant**

The area shall be checked with an appropriate refrigerant detector prior to and during work, to ensure the technician is aware of potentially toxic or flammable atmospheres. Ensure that the leak detection equipment being used is suitable for use with all applicable refrigerants, i. e. non-sparking, adequately sealed or intrinsically safe.

## **Presence of fire extinguisher**

If any hot work is to be conducted on the refrigerating equipment or any associated parts, appropriate fire extinguishing equipment shall be available to hand. Have a dry powder or CO2 fire extinguisher adjacent to the charging area

## **No ignition sources**

No person carrying out work in relation to a REFRIGERATING SYSTEM which involves exposing any pipe work shall use any sources of ignition in such a manner that it may lead to the risk of fire or explosion. All possible ignition sources, including cigarette smoking, should be kept sufficiently far away from the site of installation, repairing, removing and disposal, during which refrigerant can possibly be released to the surrounding space. Prior to work taking place, the area around the equipment is to be surveyed to make sure that there are no flammable hazards or ignition risks. "No Smoking" signs shall be displayed.

## **Ventilated area**

Ensure that the area is in the open or that it is adequately ventilated before breaking into the system or conducting any hot work. A degree of ventilation shall continue during the period that the work is carried out. The ventilation should safely disperse any released refrigerant and preferably expel it externally into the atmosphere.

## **Checks to the refrigerating equipment**

Where electrical components are being changed, they shall be fit for the purpose and to the correct specification. At all times the manufacturer's maintenance and service guidelines shall be followed. If in doubt, consult the manufacturer's technical department for assistance.

The following checks shall be applied to installations using FLAMMABLE REFRIGERANTS:

- the actual REFRIGERANT CHARGE is in accordance with the room size within which the refrigerant containing parts are installed;
- the ventilation machinery and outlets are operating adequately and are not obstructed;
- if an indirect refrigerating circuit is being used, the secondary circuit shall be checked for the presence of refrigerant
- marking to the equipment continues to be visible and legible. Markings and signs that are illegible shall be corrected;
- refrigerating pipe or components are installed in a position where they are unlikely to be exposed to any substance which may corrode refrigerant containing components, unless the components are constructed of materials which are inherently resistant to being corroded or are suitably protected against being so corroded.

## **Checks to electrical devices**

Repair and maintenance to electrical components shall include initial safety checks and component inspection procedures. If a fault exists that could compromise safety, then no electrical supply shall be

connected to the circuit until it is satisfactorily dealt with. If the fault cannot be corrected immediately but it is necessary to continue operation, an adequate temporary solution shall be used. This shall be reported to the owner of the equipment so all parties are advised. Initial safety checks shall include:

- That capacitors are discharged: this shall be done in a safe manner to avoid possibility of sparking;
- That no live electrical components and wiring are exposed while charging, recovering or purging the system;
- That there is continuity of earth bonding.

### **Repairs to sealed components**

Sealed electrical components shall be replaced.

### **Repair to intrinsically safe components**

Intrinsically safe components must be replaced.

### **Cabling**

Check that cabling will not be subject to wear, corrosion, excessive pressure, vibration, sharp edges or any other adverse environmental effects. The check shall also take into account the effects of aging or continual vibration from sources such as compressors or fans.

### **Detection of flammable refrigerants**

Under no circumstances shall potential sources of ignition be used in the searching for or detection of refrigerant leaks. A halide torch (or any other detector using a naked flame) shall not be used.

The following leak detection methods are deemed acceptable for all refrigerant systems.

Electronic leak detectors may be used to detect refrigerant leaks but, in the case of FLAMMABLE REFRIGERANTS, the sensitivity may not be adequate, or may need re-calibration. (Detection equipment shall be calibrated in a refrigerant-free area.) Ensure that the detector is not a potential source of ignition and is suitable for the refrigerant used. Leak detection equipment shall be set at a percentage of the LFL of the refrigerant and shall be calibrated to the refrigerant employed, and the appropriate percentage of gas (25 % maximum) is confirmed.

Leak detection fluids are also suitable for use with most refrigerants but the use of detergents containing chlorine shall be avoided as the chlorine may react with the refrigerant and corrode the copper pipe-work.

If a leak is suspected, all naked flames shall be removed/extinguished.

If a leakage of refrigerant is found which requires brazing, all of the refrigerant shall be recovered from the system, or isolated (by means of shut off valves) in a part of the system remote from the leak.

Removal of refrigerant shall be according to **Removal and evacuation**.

### **Removal and evacuation**

When breaking into the refrigerant circuit to make repairs – or for any other purpose –conventional procedures shall be used. However, for flammable refrigerants it is important that best practice be followed, since flammability is a consideration. The following procedure shall be adhered to:

- safely remove refrigerant following local and national regulations;
- evacuate;
- purge the circuit with inert gas (optional for A2L);
- evacuate (optional for A2L);
- continuously flush or purge with inert gas when using flame to open circuit; and
- open the circuit.

The refrigerant charge shall be recovered into the correct recovery cylinders if venting is not allowed by local and national codes. For appliances containing flammable refrigerants, the system shall be purged with oxygen-free nitrogen to render the appliance safe for flammable refrigerants. This process might need to be repeated several times. Compressed air or oxygen shall not be used for purging refrigerant systems.

For appliances containing flammable refrigerants, refrigerants purging shall be achieved by breaking the vacuum in the system with oxygen-free nitrogen and continuing to fill until the working pressure is achieved, then venting to atmosphere, and finally pulling down to a vacuum (optional for A2L). This process shall be repeated until no refrigerant is within the system (optional for A2L). When the final oxygen-free nitrogen charge is used, the system shall be vented down to atmospheric pressure to enable work to take place.

The outlet for the vacuum pump shall not be close to any potential ignition sources, and ventilation shall be available.

### **Charging procedures**

In addition to conventional charging procedures, the following requirements shall be followed.

- Ensure that contamination of different refrigerants does not occur when using charging equipment. Hoses or lines shall be as short as possible to minimise the amount of refrigerant contained in them.
- Cylinders shall be kept in an appropriate position according to the instructions.
- Ensure that the REFRIGERATING SYSTEM is earthed prior to charging the system with refrigerant
- Label the system when charging is complete (if not already).
- Extreme care shall be taken not to overfill the REFRIGERATING SYSTEM.

Prior to recharging the system, it shall be pressure-tested with the appropriate purging gas. The system shall be leak-tested on completion of charging but prior to commissioning. A follow up leak test shall be carried out prior to leaving the site.

### **Decommissioning**

Before carrying out this procedure, it is essential that the technician is completely familiar with the equipment and all its detail. It is recommended good practice that all refrigerants are recovered safely. Prior to the task being carried out, an oil and refrigerant sample shall be taken in case analysis is required prior to re-use of recovered refrigerant. It is essential that electrical power is available before the task is commenced.

- a) Become familiar with the equipment and its operation.
- b) Isolate system electrically.
- c) Before attempting the procedure, ensure that:
  - mechanical handling equipment is available, if required, for handling refrigerant cylinders;
  - all personal protective equipment is available and being used correctly;
  - the recovery process is supervised at all times by a competent person;
  - recovery equipment and cylinders conform to the appropriate standards.
- d) Pump down refrigerant system, if possible.
- e) If a vacuum is not possible, make a manifold so that refrigerant can be removed from various parts of the system.
- f) Make sure that cylinder is situated on the scales before recovery takes place.
- g) Start the recovery machine and operate in accordance with instructions.

- h) Do not overfill cylinders (no more than 80 % volume liquid charge).
- i) Do not exceed the maximum working pressure of the cylinder, even temporarily.
- j) When the cylinders have been filled correctly and the process completed, make sure that the cylinders and the equipment are removed from site promptly and all isolation valves on the equipment are closed off.
- k) Recovered refrigerant shall not be charged into another REFRIGERATING SYSTEM unless it has been cleaned and checked

### Labelling

Equipment shall be labelled stating that it has been de-commissioned and emptied of refrigerant. The label shall be dated and signed. For appliances containing FLAMMABLE REFRIGERANTS, ensure that there are labels on the equipment stating the equipment contains FLAMMABLE REFRIGERANT.

### Recovery

When removing refrigerant from a system, either for servicing or decommissioning, it is recommended good practice that all refrigerants are removed safely.

When transferring refrigerant into cylinders, ensure that only appropriate refrigerant recovery cylinders are employed. Ensure that the correct number of cylinders for holding the total system charge is available. All cylinders to be used are designated for the recovered refrigerant and labelled for that refrigerant (i. e. special cylinders for the recovery of refrigerant). Cylinders shall be complete with pressure-relief valve and associated shut-off valves in good working order. Empty recovery cylinders are evacuated and, if possible, cooled before recovery occurs.

The recovery equipment shall be in good working order with a set of instructions concerning the equipment that is at hand and shall be suitable for the recovery of the flammable refrigerant. If in doubt, the manufacturer should be consulted. In addition, a set of calibrated weighing scales shall be available and in good working order. Hoses shall be complete with leak-free disconnect couplings and in good condition.

The recovered refrigerant shall be processed according to local legislation in the correct recovery cylinder, and the relevant waste transfer note arranged. Do not mix refrigerants in recovery units and especially not in cylinders.

If compressors or compressor oils are to be removed, ensure that they have been evacuated to an acceptable level to make certain that flammable refrigerant does not remain within the lubricant. The compressor body shall not be heated by an open flame or other ignition sources to accelerate this process. When oil is drained from a system, it shall be carried out safely.



Be sure the air conditioner is grounded.

In order to avoid electric shock, make sure that the unit is grounded and that the ground wire is not connected to a gas or water pipe, lightning conductor or telephone ground wire.

Do not operate the air conditioner with wet hands. An electric shock may happen.

Do not touch the heat exchanger fins. These fins are sharp and could cut you.

To avoid oxygen deficiency, ventilate the room sufficiently if equipment with a burner is used together with the air conditioner.

Arrange the drain hose to ensure smooth drainage. Incomplete drainage may cause wetting of the building, furniture, etc.

Never touch the internal parts of the controller.

Do not remove the blower access panel. Some parts inside are dangerous to touch, and machine issues may occur.

Attention is drawn to the fact that additional transportation regulations may exist with respect to the equipment containing a flammable gas. The maximum number of pieces of equipment or the

---



configuration of the equipment permitted to be transported together will be determined by the applicable transport regulations.

Signs for similar appliances used in a work area are generally addressed by local regulations and give the minimum requirements for the provision of safety and/or health signs for a work location. All required signs are to be maintained and employers should ensure that employees receive suitable and sufficient instruction and training on the meaning of appropriate safety signs and the actions that need to be taken in connection with these signs.

The effectiveness of signs should not be diminished by too many signs being placed together. Any pictograms used should be as simple as possible and contain only essential details.

The storage of the appliance should be in accordance with the applicable regulations or instructions, whichever is more stringent.

Storage package protection should be constructed such a way that mechanical damage to the equipment inside the package will not cause a leak of the refrigerant charge.

The maximum number of pieces of equipment permitted to be stored together will be determined by local regulations.

Do not operate the air conditioner when using a room fumigation - type insecticide. Failure to observe this precaution could cause the chemicals to become deposited in the unit, which could endanger the health of those who are hypersensitive to chemicals. It may also cause the refrigerant sensor to alarm.

Do not place appliances which produce open flames in places exposed to the air flow from the unit or under the indoor unit. It may cause incomplete combustion or deformation of the unit due to the heat.

Do not install the air conditioner in a location where flammable gas may leak out. If the gas leaks out and stays around the air conditioner, a fire may break out.

Any additional equipment installed in our unit may not cause negative influence on normal operation, such as UV lights, humidifier and etc.

The appliance uses R32 refrigerant.



## 2 . Dimensions

### 2.1 Unit Dimensions (24K/36K)

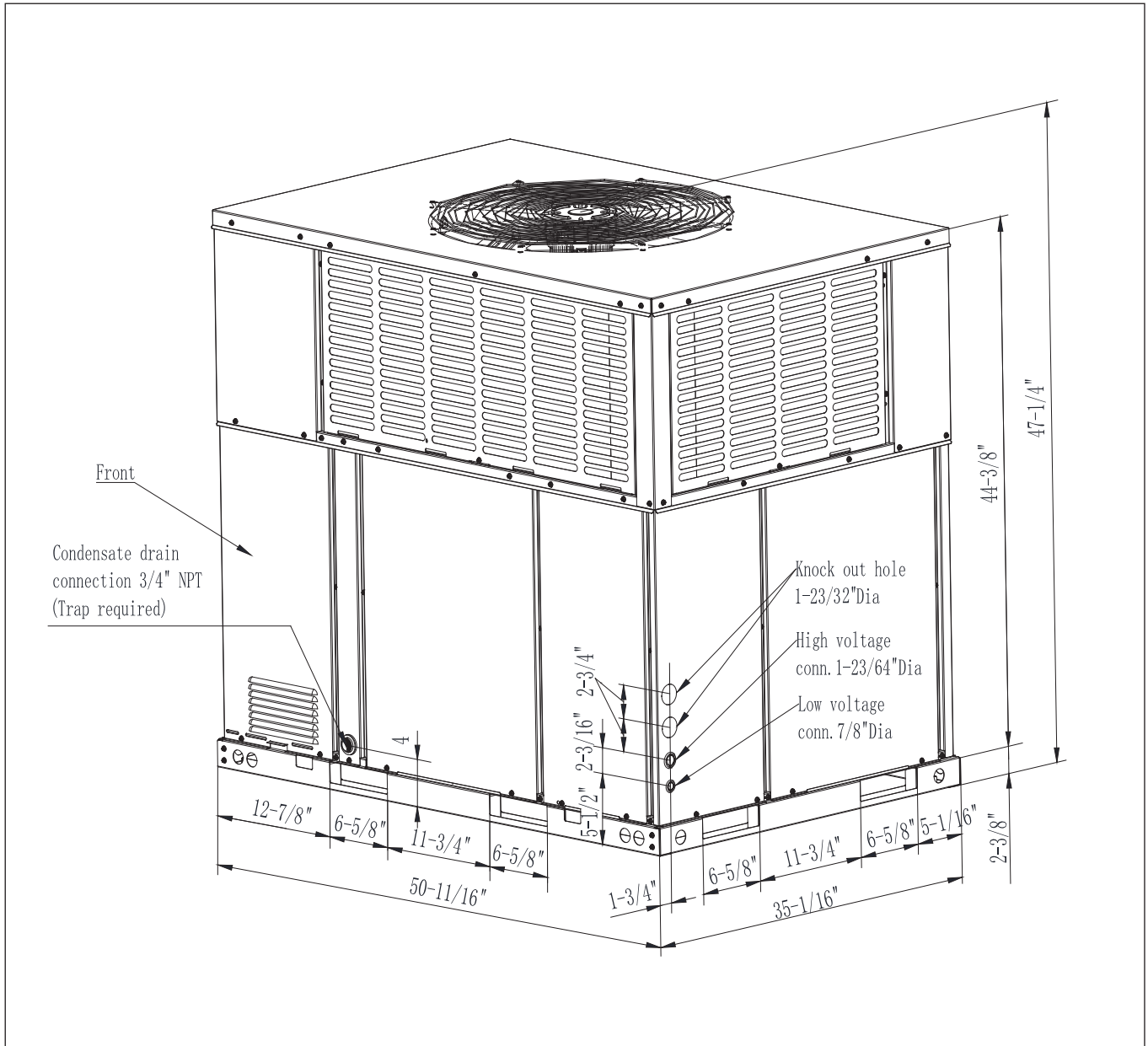

Figure 1

Heat Pump Model	Net Weight	Gross Weight
24K-18SEER	415 lbs (188kg)	428 lbs (194kg)
36K-18SEER	415 lbs (188kg)	428 lbs (194kg)

Table 1 Unit Weights

## 2.2 Dimensions - Back and Bottom (24K/36K)

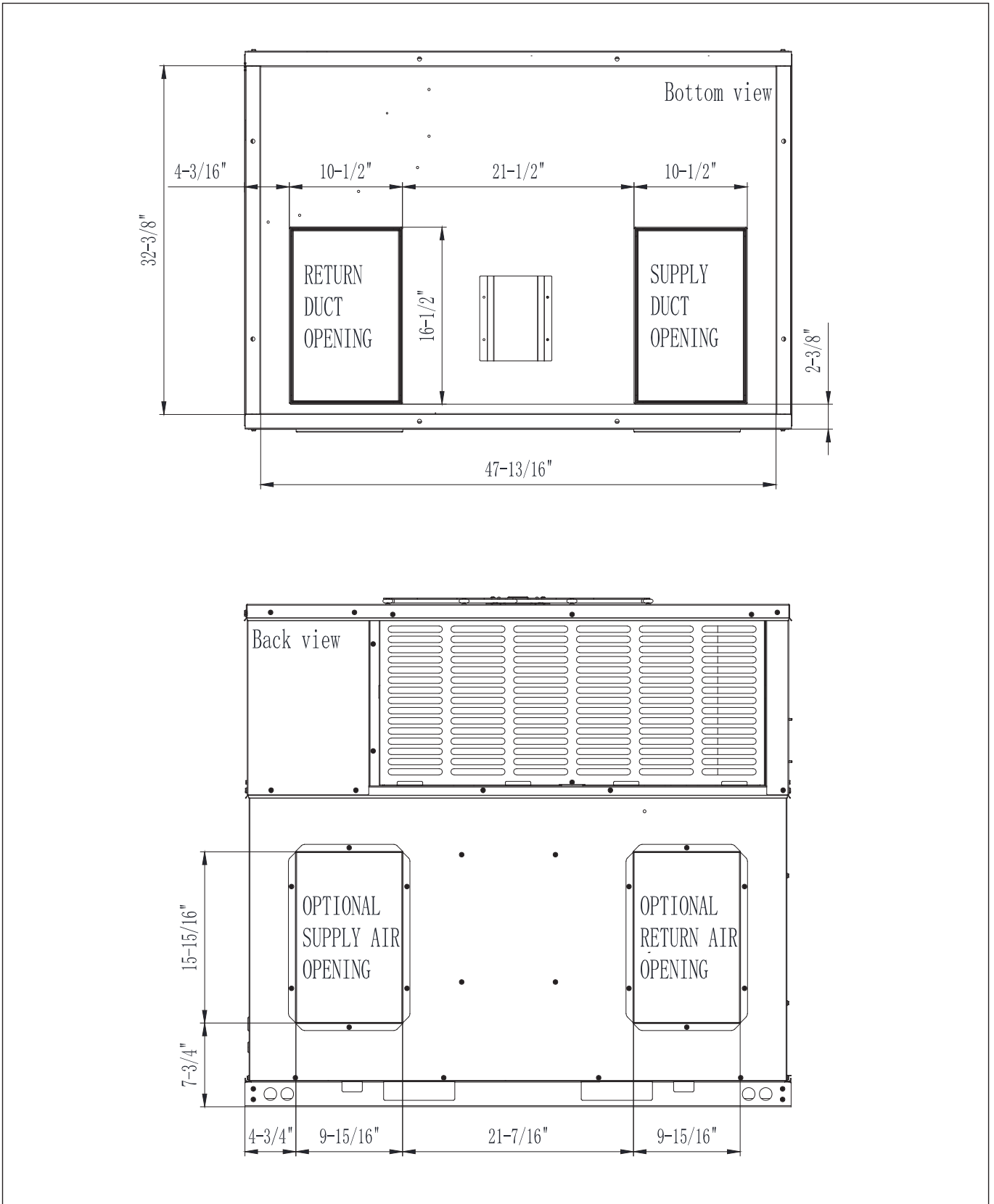

Figure 2

### 2.3 Dimensions - Right and Top (24K/36K)

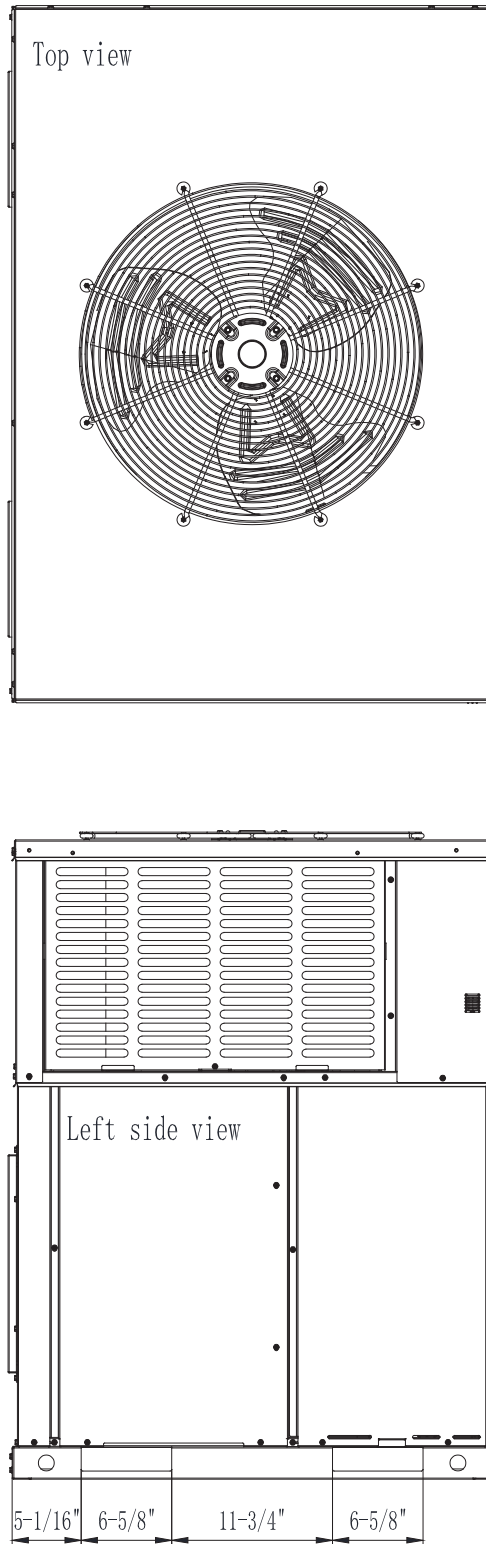

Figure 3

## 2.4 Unit Dimensions (48K/60K)

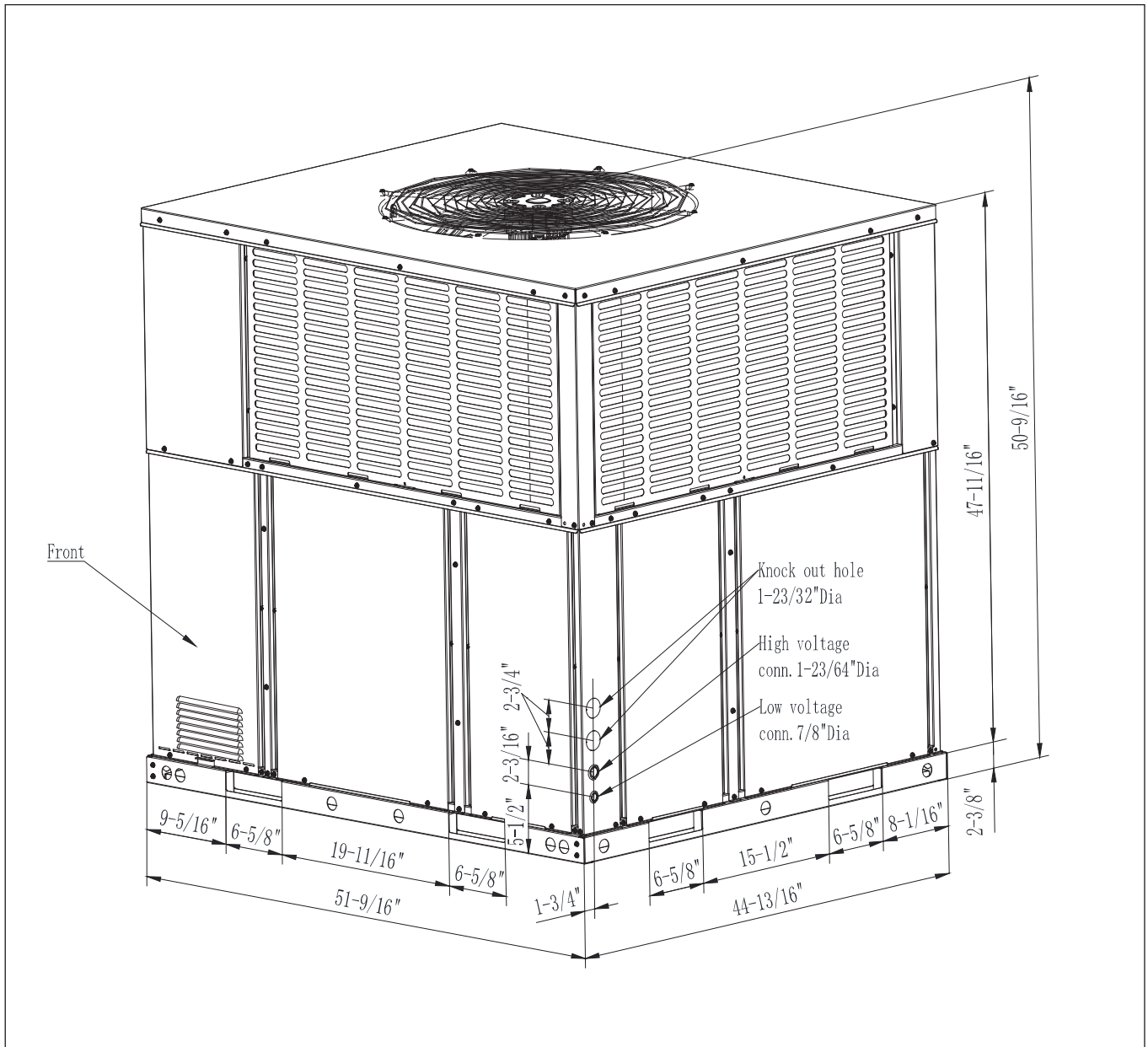

Figure 4

Heat Pump Model	Net Weight	Gross Weight
48K-18SEER	551 lbs (250kg)	568 lbs (258kg)
60K-18SEER	551 lbs (250kg)	568 lbs (258kg)

Table 2 Unit Weights

## 2.5 Dimensions - Back and Bottom (48K/60K)

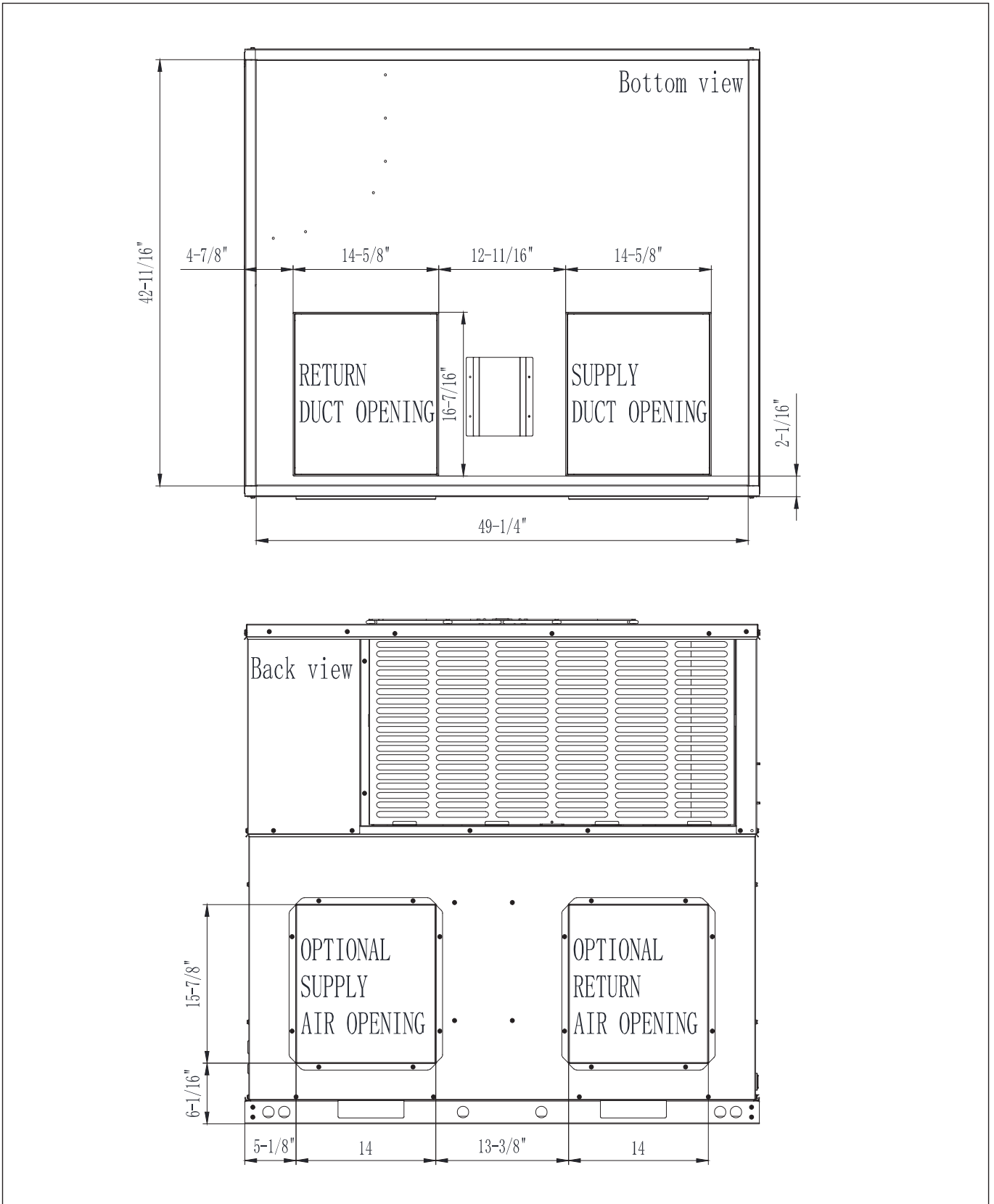

Figure 5

## 2.6 Dimensions - Right and Top (48K/60K)

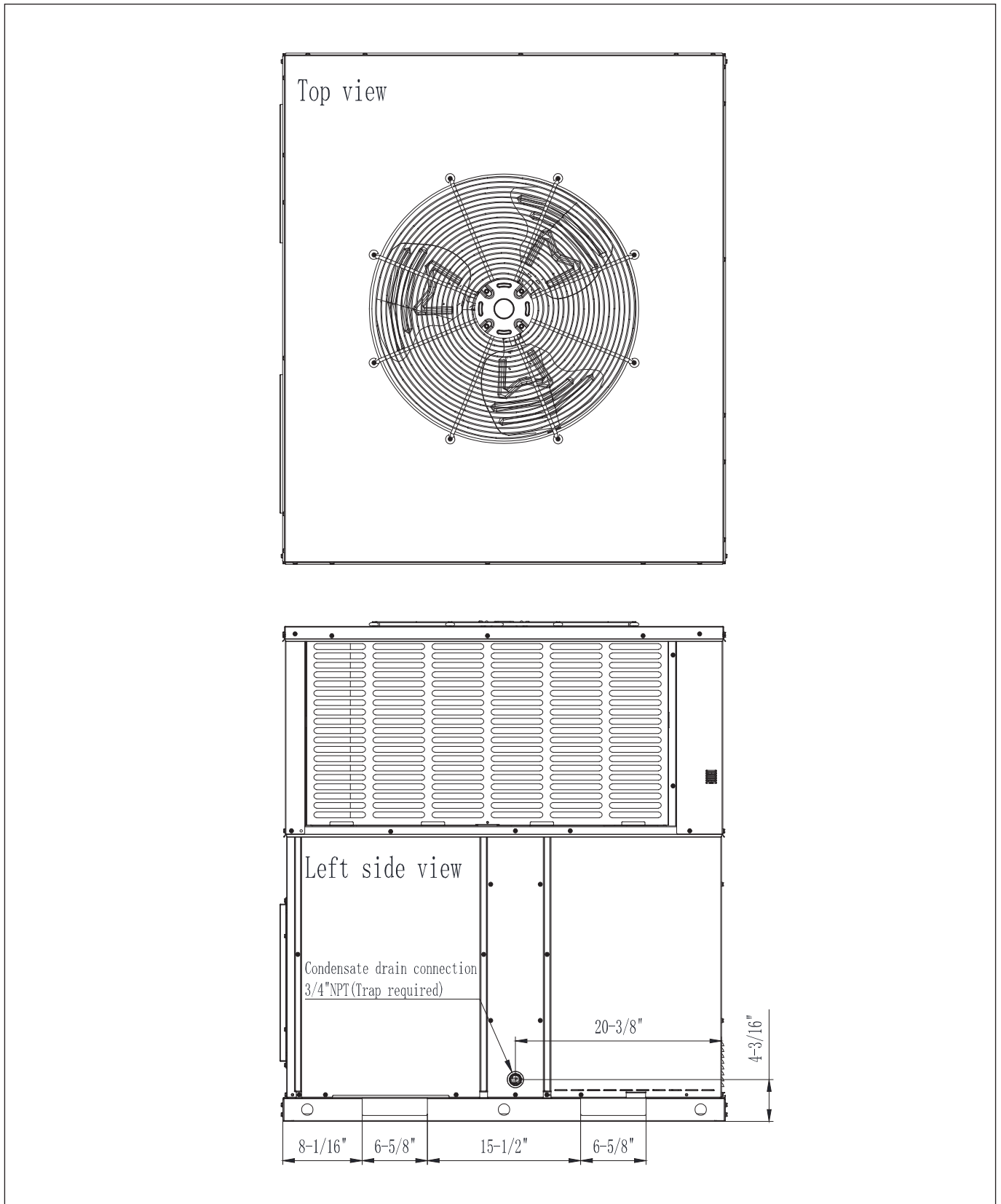

Figure 6

## 3 . Installation

### 3.1 Pre-Installation

Before installation, carefully check the following:

1. Unit should be installed in accordance with national and local safety codes, including but not limited to ANSI/NFPA No. 70, local plumbing and wastewater codes and any other applicable codes.
2. For rooftop installation, be sure the structure has enough strength to support the weight of unit. Unit must be installed on a field supplied roof curb or rack and leveled.
3. For ground level installation, a field supplied level slab must be used.
4. Condenser airflow should not be restricted.
5. On applications when a roof curb is used, the unit must be positioned on the curb so the front of the unit is tight against the curb. If the unit is to be mounted on a curb in a downflow application, refer to Figure 17, and convert panels prior to rigging and lifting. The panel removal process may require the unit to be on the ground.

### 3.2 Rigging And Lifting

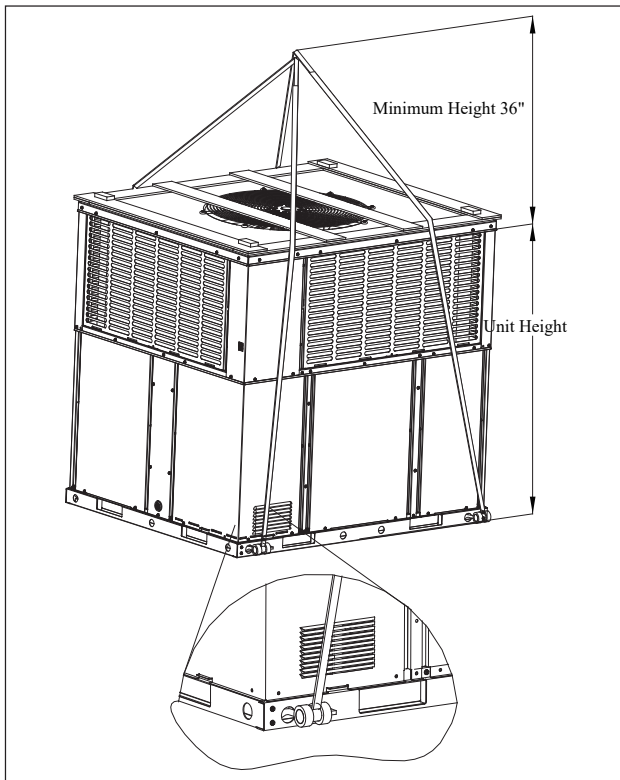

Figure 7

Exercise care when moving the unit. Do not remove any packaging until the unit is near the place of installation. Rig the unit by attaching chain or cable slings to the lifting holes provided in the base rails. Spreader bars, whose length exceeds the largest dimension across the unit, MUST be used across the top of the unit.

When rigging/lifting the unit, the minimum height between the top of the rigging cables' connection point and top of unit should be 36 in. Refer to Figure 7.



**CAUTION:**

Before lifting, make sure the unit weight is distributed equally on the rigging cables so it will lift evenly.



**CAUTION:**

All panels must be secured in place when the unit is lifted. The condenser coils should be protected from rigging cable damage with plywood or other suitable material.

### 3.3 Location Restrictions

Ensure the top discharge area is unrestricted for at least 60 inches above the unit.

Do not locate outdoor unit near bedrooms since normal operational noise levels may be disturbing to building occupants.

Position unit to allow adequate space for unobstructed airflow, wiring, and serviceability.

Do not restrict outdoor airflow. An air restriction at either the outdoor air inlet or the fan discharge may be detrimental to compressor life.

Do not place the unit where water, ice, or snow from an overhang or roof will damage or flood the unit. Do not install the unit on carpeting or other combustible materials. Slab-mounted units should be at least 2 in. (51 mm) above the highest expected water and runoff levels. Do not use unit if it has been under water.

Maintain a distance of 24 inches between units. Position unit so water, snow, or ice from roof or overhang cannot fall directly on unit.

See Fig. 9 and Fig. 10 for minimum clearance requirements.

Cold climate considerations (heat pump only)

**NOTICE:**

Precautions must be taken for units being installed in areas where snow accumulation and prolonged below-freezing temperatures occur.

- ▶ Units should be elevated 3-12 inches above the pad or rooftop, depending on local weather. This additional height will allow drainage of snow and will permit condensate water to drain when the unit is in defrost mode. Ensure that drain holes in unit base pan are unobstructed, preventing drainage of defrost water (See Fig.11).
- ▶ If possible, avoid locations that are prone to snow drifts. If not possible, a snow drift barrier should be installed around the unit to prevent a build-up of snow on the sides of the unit.



Ensure that Condensate Drain side is pitched lower than the opposite side.

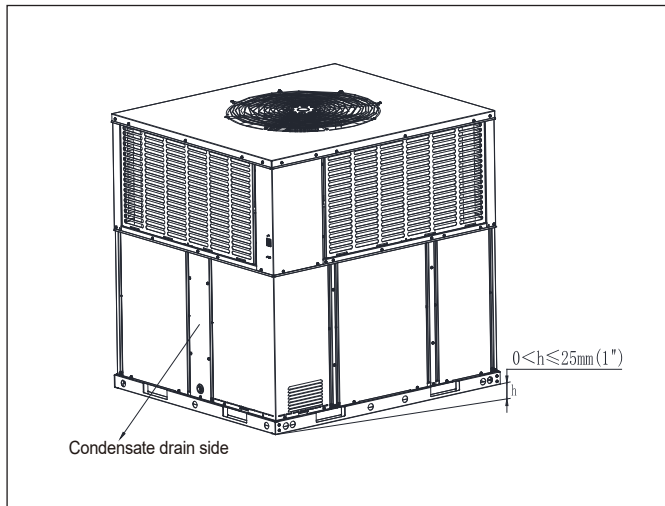

Figure 8

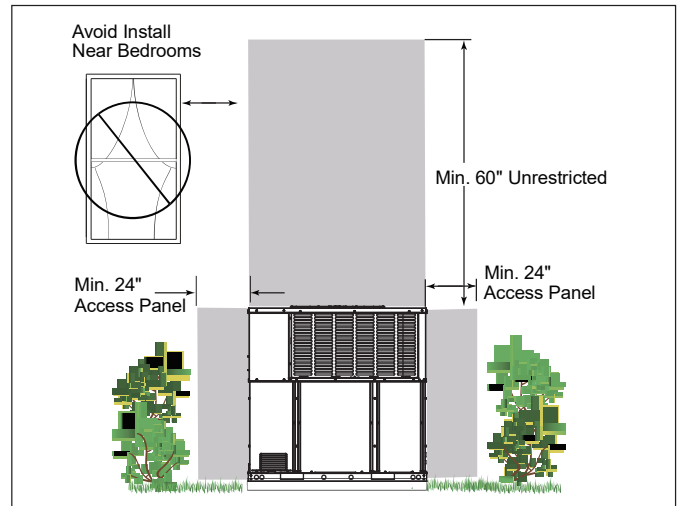

Figure 9

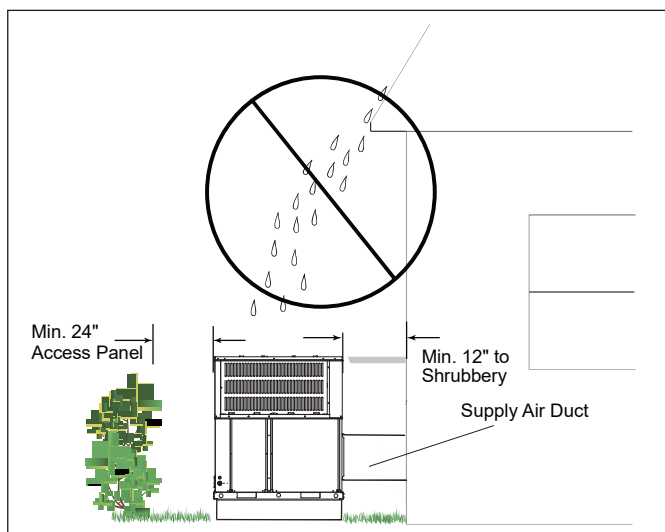

Figure 10

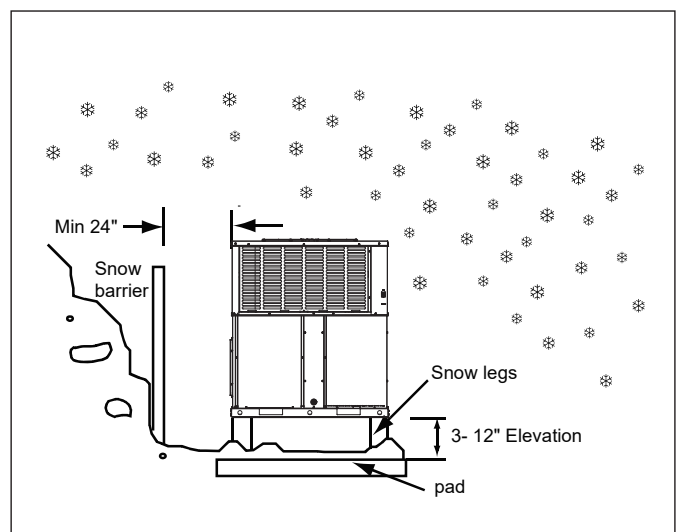

Figure 11



A minimum clearance of 24" should be maintained adjacent to all access/service panels. Refer to local code requirements for additional clearance requirements.

### Corrosive Environment

Exposure to a corrosive environment may shorten the life of the performance. Corrosive elements include, but are not limited to: sodium chloride, sodium hydroxide, sodium sulfate, and other compounds commonly found in ocean water, sulfur, chlorine, fluorine, fertilizers, and various chemical contaminants from industry/manufacturing plants. If installed in areas which may be exposed to corrosive environments, special attention should be given to the equipment placement and maintenance.

- Lawn sprinklers/hoses/waste water should not spray directly on the unit cabinet for prolonged periods of time.
- In coastal areas: locate the unit on the side of the building or roof away from the waterfront.
- Fencing or shrubbery may provide some shielding protection to the unit, however minimum unit clearances must still be maintained.
- Every three months, wash the outdoor coil and any exposed cabinet surfaces.

### 3.4 Rooftop Installation - Curb Mounting

The manufacturer does not supply roof curbs, they must be field supplied. The curb so the front of the unit is tight against the curb (see Figure 12 or Figure 13 Roof Curb Dimension).

The default orientation from the factory is for horizontal airflow. Convert the unit to downflow using the following procedure:

1. Remove the sheet metal screws securing the supply air cover and the sheet metal screws securing the return air cover from the base of the unit. Remove the covers from the base. See Figure 17.
2. Place the covers over the horizontal supply and return openings (painted side out). Align the screw holes, and secure using the same screws removed in step 1. See Figure 17.

Install the field-supplied roof mounting curb according to the Installation Instructions supplied with the curb. Install insulation, cant strips, roofing, and flashing. Ductwork must be attached to curb.

**NOTICE:**

The gasketing of the unit to the roof curb is critical for a water tight seal. Install gasketing material supplied with the field supplied roof curb. Improperly applied gasketing also can result in air leaks and poor unit performance.

**NOTICE:**

The unit must be secured to the curb by installing screws through the bottom of the curb flange and into the unit base rails.

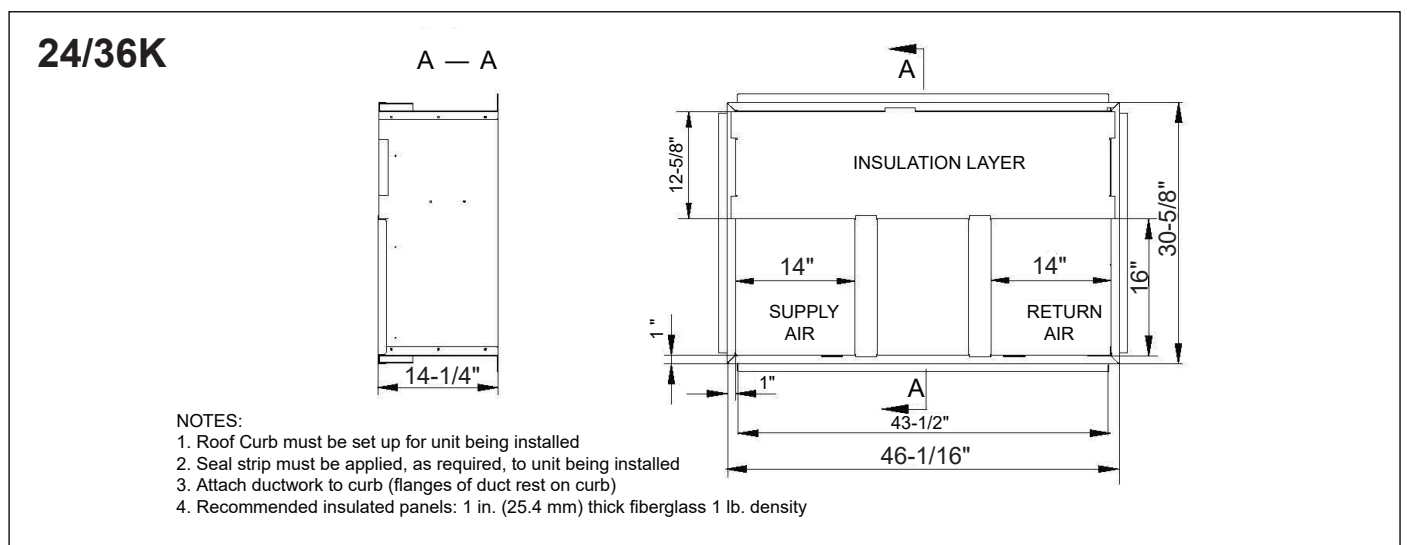

Figure 12 Roof Curb Details

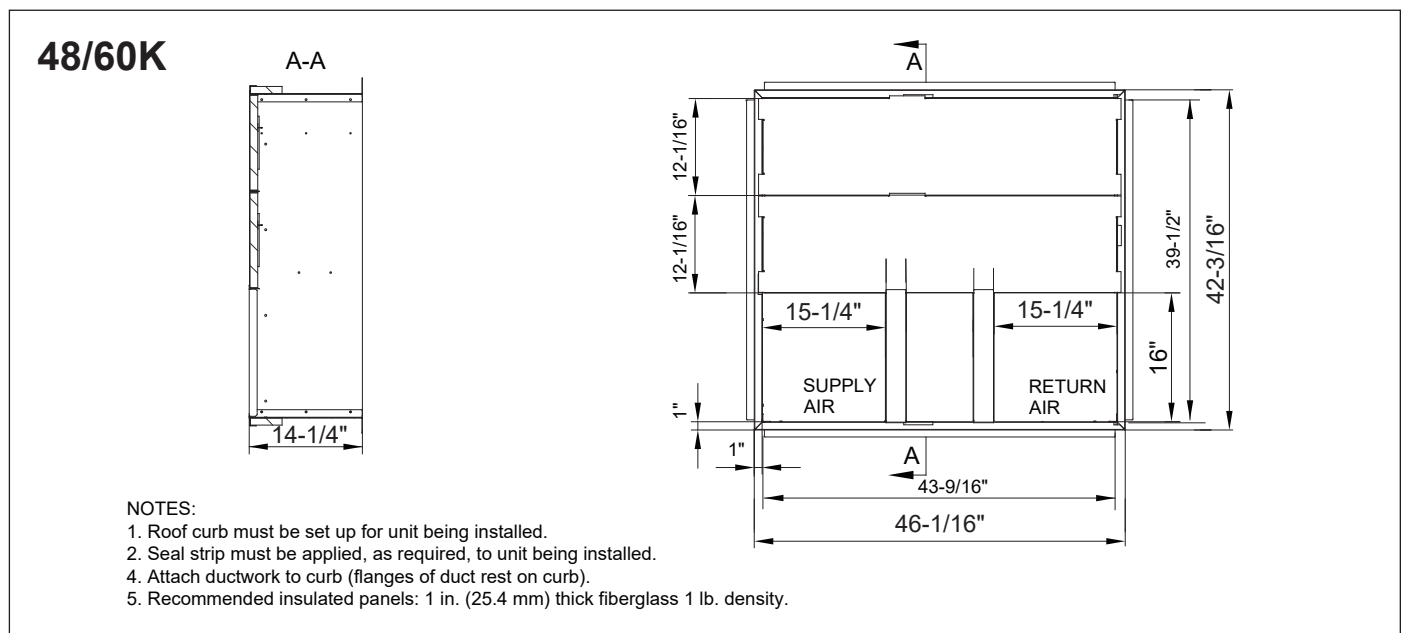

Figure 13 Roof Curb Details

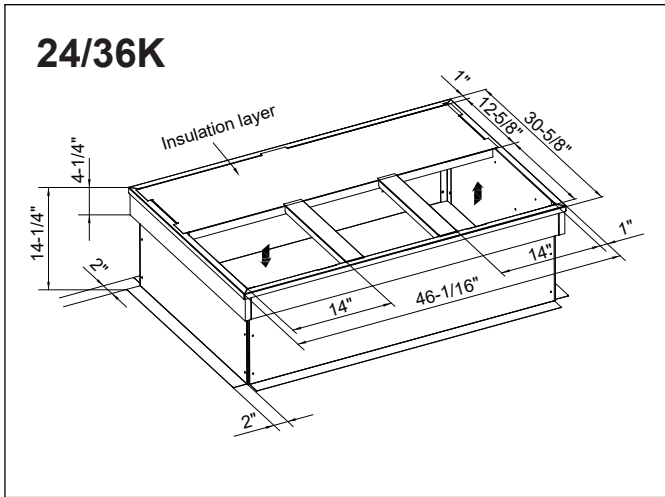

Figure 14 Roof Curb Dimensions

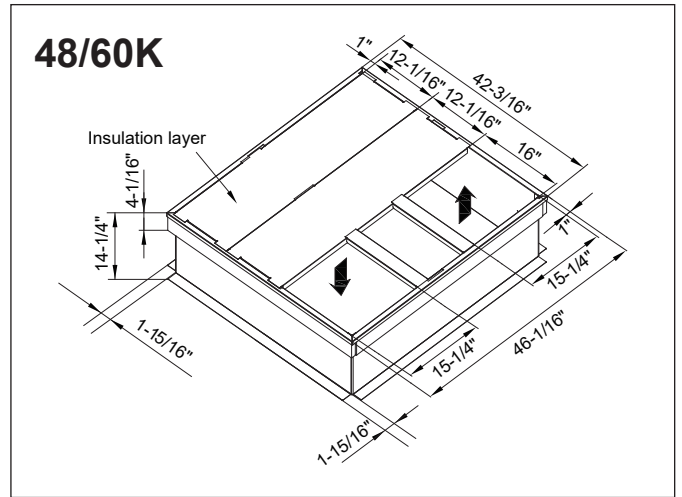

Figure 15 Roof Curb Dimensions



For units applied with a roof curb, the minimum clearance may be reduced from 1 inch to 1/2 inch between combustible roof curb material and supply air duct.

**NOTICE: UNIT/STRUCTURAL DAMAGE HAZARD**

Failure to follow this caution may result in property damage. Ensure there is sufficient clearance for saw blade when cutting the outer horizontal flange of the roof curb so there is no damage to the roof or flashing.

## 4 . Airflow Performance

Airflow performance data is based on cooling performance with a coil and no filter in place. Check the performance table for appropriate unit size selection.

External static pressure should stay within the minimum and maximum limits shown in the table below in order to ensure proper operation of both cooling, heating, and electric heating operation.

### AC-I-24-INV-HP-PKG

Model Number	Motor Speed	External Static Pressure - Inches W.C.[kPa]										
		0	0.08[0.02]	0.25[0.05]	0.28[0.07]	0.4[0.10]	0.48[0.12]	0.5[0.125]	0.6[0.15]	0.68[0.17]	0.8[0.20]	
24K - 18SEER	Tap(1)	SCFM	875	809	703	637	543	479	464	384	333	303
		Watts	89	93	100	104	109	113	114	117	118	120
		Amps	0.86	0.89	0.93	0.96	1.02	1.05	1.06	1.09	1.12	1.12
	Tap(2)	SCFM	1049	991	901	842	762	708	695	628	579	499
		Watts	140	145	152	156	163	166	167	173	178	184
		Amps	1.28	1.32	1.37	1.41	1.46	1.49	1.5	1.54	1.58	1.63
	Tap(3)	SCFM	1184	1136	1059	1000	925	874	862	804	759	691
		Watts	195	200	207	214	222	227	230	234	238	246
		Amps	1.64	1.68	1.74	1.79	1.86	1.91	2	2.04	2.03	2.06
	Tap(4)	SCFM	1354	1312	1248	1197	1122	1077	1067	1010	970	913
		Watts	283	288	295	301	312	318	320	327	332	340
		Amps	2.38	2.41	2.48	2.53	2.62	2.66	2.67	2.71	2.75	2.86
	Tap(5)	SCFM	1507	1466	1405	1368	1296	1255	1245	1196	1157	1100
		Watts	529	540	556	566	581	592	594	607	619	635
		Amps	3.22	3.26	3.34	3.39	3.48	3.55	3.56	3.63	3.68	3.8

Table 3

### AC-I-36-INV-HP-PKG

Model Number	Motor Speed	External Static Pressure - Inches W.C.[kPa]										
		0	0.08[0.02]	0.25[0.05]	0.28[0.07]	0.4[0.10]	0.48[0.12]	0.5[0.125]	0.6[0.15]	0.68[0.17]	0.8[0.20]	
36K - 18SEER	Tap(1)	SCFM	875	809	703	637	543	479	464	384	333	303
		Watts	89	93	100	104	109	113	114	117	118	120
		Amps	0.86	0.89	0.93	0.96	1.02	1.05	1.06	1.09	1.12	1.12
	Tap(2)	SCFM	1049	991	901	842	762	708	695	628	579	499
		Watts	140	145	152	156	163	166	167	173	178	184
		Amps	1.28	1.32	1.37	1.41	1.46	1.49	1.5	1.54	1.58	1.63
	Tap(3)	SCFM	1184	1136	1059	1000	925	874	862	804	759	691
		Watts	195	200	207	214	222	227	230	234	238	246
		Amps	1.64	1.68	1.74	1.79	1.86	1.91	2	2.04	2.03	2.06
	Tap(4)	SCFM	1354	1312	1248	1197	1122	1077	1067	1010	970	913
		Watts	283	288	295	301	312	318	320	327	332	340
		Amps	2.38	2.41	2.48	2.53	2.62	2.66	2.67	2.71	2.75	2.86
	Tap(5)	SCFM	1507	1466	1405	1368	1296	1255	1245	1196	1157	1100
		Watts	529	540	556	566	581	592	594	607	619	635
		Amps	3.22	3.26	3.34	3.39	3.48	3.55	3.56	3.63	3.68	3.8

Table 4

### AC-I-48-INV-HP-PKG

Model Number	Motor Speed	External Static Pressure - Inches W.C.[kPa]										
		0	0.08[0.02]	0.25[0.05]	0.28[0.07]	0.4[0.10]	0.48[0.12]	0.5[0.125]	0.6[0.15]	0.68[0.17]	0.8[0.20]	
48K - 18SEER	Tap(1)	SCFM	1177	1113	1043	992	913	861	848	783	731	653
		Watts	125	128	140	145	154	160	162	169	175	185
		Amps	1.2	1.23	1.31	1.36	1.42	1.47	1.48	1.54	1.59	1.65
	Tap(2)	SCFM	1427	1378	1321	1276	1212	1173	1166	1108	1066	1004
		Watts	208	212	226	233	244	252	254	263	271	282
		Amps	1.87	1.91	2.01	2.07	2.15	2.21	2.24	2.29	2.37	2.44
	Tap(3)	SCFM	1728	1695	1644	1609	1553	1528	1522	1478	1444	1400
		Watts	358	367	380	389	401	411	412	425	437	445
		Amps	3.04	3.11	3.2	3.27	3.36	3.45	3.46	3.55	3.64	3.7
	Tap(4)	SCFM	1937	1904	1858	1826	1783	1755	1748	1708	1677	1656
		Watts	498	507	522	531	547	558	562	575	586	594
		Amps	4.08	4.16	4.27	4.33	4.48	4.52	4.55	4.65	4.74	4.79
	Tap(5)	SCFM	1978	1951	1909	1878	1833	1802	1792	1752	1723	1677
		Watts	529	540	556	566	581	592	594	607	619	635
		Amps	4.27	4.35	4.46	4.53	4.65	4.73	4.74	4.87	4.96	5.07

Table 5

# AC-I-60-INV-HP-PKG & AC-I-60-INV-HP-3PH-PKG

Model Number	Motor Speed	External Static Pressure - Inches W.C.[kPa]										
		0	0.08[0.02]	0.25[0.05]	0.28[0.07]	0.4[0.10]	0.48[0.12]	0.5[0.125]	0.6[0.15]	0.68[0.17]	0.8[0.20]	
60K - 18SEER	Tap(1)	SCFM	1177	1113	1043	992	913	861	848	783	731	653
		Watts	125	128	140	145	154	160	162	169	175	185
		Amps	1.2	1.23	1.31	1.36	1.42	1.47	1.48	1.54	1.59	1.65
	Tap(2)	SCFM	1427	1378	1321	1276	1212	1173	1166	1108	1066	1004
		Watts	208	212	226	233	244	252	254	263	271	282
		Amps	1.87	1.91	2.01	2.07	2.15	2.21	2.24	2.29	2.37	2.44
	Tap(3)	SCFM	1728	1695	1644	1609	1553	1528	1522	1478	1444	1400
		Watts	358	367	380	389	401	411	412	425	437	445
		Amps	3.04	3.11	3.2	3.27	3.36	3.45	3.46	3.55	3.64	3.7
	Tap(4)	SCFM	1937	1904	1858	1826	1783	1755	1748	1708	1677	1656
		Watts	498	507	522	531	547	558	562	575	586	594
		Amps	4.08	4.16	4.27	4.33	4.48	4.52	4.55	4.65	4.74	4.79
	Tap(5)	SCFM	1978	1951	1909	1878	1833	1802	1792	1752	1723	1677
		Watts	529	540	556	566	581	592	594	607	619	635
		Amps	4.27	4.35	4.46	4.53	4.65	4.73	4.74	4.87	4.96	5.07

Table 6

Bold outlined areas represent airflow outside of the required 300-450 cfm/ton range.

**NOTES:**

1. The high stage airflow must be used as the rated airflow for the full load operation of machine.
2. The rated airflow of systems without electric heater kits requires between 300 and 450 cubic feet of air per minute (CFM).
3. The rated airflow of systems with electric heater kits requires between 350 and 450 cubic feet of air per minute (CFM).
4. The air distribution system has the greatest effect on airflow. Therefore, the contractor should use only industry-recognized procedures.
5. Duct design and construction should be carefully done. System performance can be lowered dramatically through poor design or workmanship.
6. Air supplier ducts should be located along the perimeter of the conditioned space and properly sized. Improper location or insufficient air flow may cause drafts or noise in the ductwork.
7. Installers should balance the air distribution system to ensure proper quiet airflow to all rooms in the home. An air velocity meter or airflow hood can be used to balance and verify branch and system airflow (CFM).

**NOTES:**

## 5 . Indoor Fan Motor Function

### System Operation and Function

#### Two Stage Fan Control

The this product supports two stage fan control which requires a two stage thermostat (Y1&Y2). When there is a call for Y2, the blower motor will turn to high speed setting. When there is a call for Y1, the blower motor will turn to low speed setting. Unit will run at low speed setting when there is only G call. It will run in high speed setting when there is W/W1/W2 signal (when the electric heat kit is on).

The ECM motor supports 5 speeds(The AC motor supports 3 speeds). Customer can select the suitable speed by adjusting the SW1-1 and SW1-2 dip switches.Refer to Airflow Performance Table (Table 3 to Table 10) for reference airflow. Refer to Figure 62 or Figure 63 Wiring Diagram for dip switches settings.

If 2 stage thermostat is not available, single stage thermostat may be used, please refer to Wiring Diagram section for wiring instructions. If Y1 and Y2 are jumped, the unit will only run in high stage fan speed.

#### Anti-Cold Air Fan Delay

The Anti-Cold Air Fan Delay function utilizes a sensor (T2) located on the indoor coil, which prevents the blower from turning on until the coil has reached a certain temperature. This feature prevents cold air blow during heating operation.

1. When SW2-2 dip switch is set to the "OFF" position and the unit is in heating mode, the Anti-Cold Air Fan Delay function will activate based on the following entry conditions (all 3 conditions must be met):
  - a. Indoor Coil Temperature (T2) < 68°F
  - b. Electric heat kit is turned off
  - c. There is a call for Y1 from thermostat to indoor unit
2. This function will deactivate if ONE OF the following exit conditions are met OR the system has been operating in heating mode for 15 minutes.
  - a. T2 ≥ 86°F
  - b. Heater kit is turned on
  - c. The system is NOT running Heat mode
3. During the heating mode, if one of the exit conditions of Anti-Cold Air is satisfied, the blower motor will turn on in first stage fan speed.
4. During the heating mode, if all of the entry conditions of Anti-Cold Air are met and maintained for 120s, the blower motor will change to first stage speed.

#### Heating Fan Delay

If SW2-2 dip switch is set to the "ON" position and the unit is in heating mode, the blower will operate with a 90 second delay with the fan speed dictated by Y1 or Y2 signal.

#### Passive Dehumidication (Optional)

IDP has a Passive Dehumidification function which lowers the fan speed (first stage) with a DH call from the thermostat. This function requires proper DH wiring from the indoor unit to the thermostat (with a humidistat).



If DH wire is not connected, the unit will still function normally.

---

## 6 . Ductwork

Field ductwork must comply with the National Fire Protection Association NFPA 90A, NFPA 90B and any applicable local ordinance(s).



### WARNING: FIRE HAZARD AND CARBON MONOXIDE

Do not, under any circumstances, connect return ductwork to any other heat producing device such as fireplace insert, stove, etc. Unauthorized use of such devices may result in fire, carbon monoxide poisoning, explosion, personal injury or property.

When this product is equipped with electric heating or has already been installed with electric heating upon leaving the factory, the installation personnel must connect the air supply duct properly before powering it on for operation. It is prohibited to use it without installing the air supply duct.

Sheet metal ductwork run in unconditioned spaces must be insulated and covered with a vapor barrier. Fibrous ductwork may be used if constructed and installed in accordance with SMACNA Construction Standard on Fibrous Glass Ducts. Ductwork must comply with National Fire Protection Association as tested by U/L Standard 181 for Class I Air Ducts. Check local codes for requirements on ductwork and insulation.

- Duct system must be designed within the range of external static pressure the unit is designed to operate against. It is important that the system airflow be adequate. Make sure supply and return ductwork, grills, special filters, accessories, etc. are accounted for in total resistance. See airflow performance tables in Section 5 of this manual.
- Design the duct system in accordance with "ACCA" Manual "D" Design for Residential Winter and Summer Air Conditioning and Equipment Selection. Latest editions are available from: "ACCA" Air Conditioning Contractors of America, 1513 16th Street, N.W., Washington, D.C. 20036. If duct system incorporates flexible air duct, be sure pressure drop information (straight length plus all turns) shown in "ACCA" Manual "D" is accounted for in system.



If an elbow is included in the plenum close to the unit, it must not be smaller than the dimensions of the supply duct flange on the unit.

### NOTICE:

The front flange on the return duct (if connected to the blower casing) must not be screwed into the area where the power wiring is located. Drills or sharp screw points can damage insulation on wires located inside unit.

- Secure all ducts to roof curb and building structure on downflow discharge units. Do not connect ductwork to unit. For horizontal applications, unit is provided with flanges on the horizontal openings. All ductwork should be secured to the flanges using proper fasteners for the type of duct used and tape the duct-to unit joint as required to prevent air leaks.

### NOTICE:

When fastening ductwork to the side duct flanges on the unit, insert the screws through the duct flanges only. DO NOT insert the screws through the casing. Outdoor ductwork must be insulated and waterproofed.



Be sure to note supply and return openings. Refer to Figure 2 or Figure 5 for information concerning supply and return air duct dimensions.

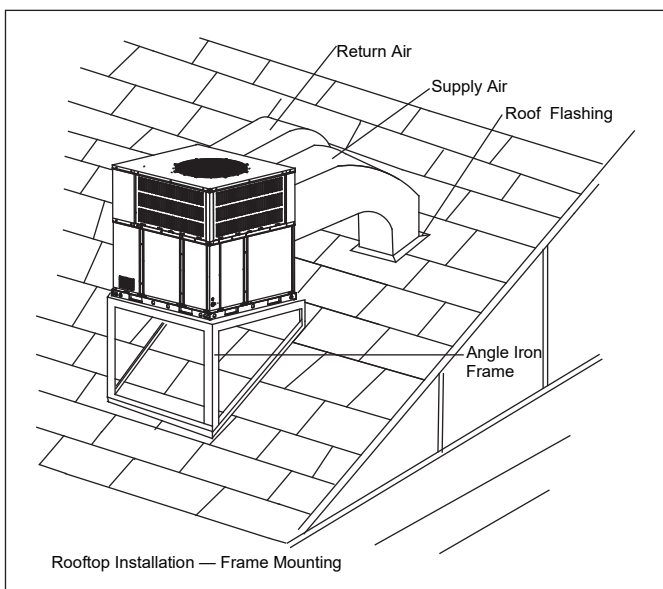

Figure 16 Rooftop Installation—Frame Mounting

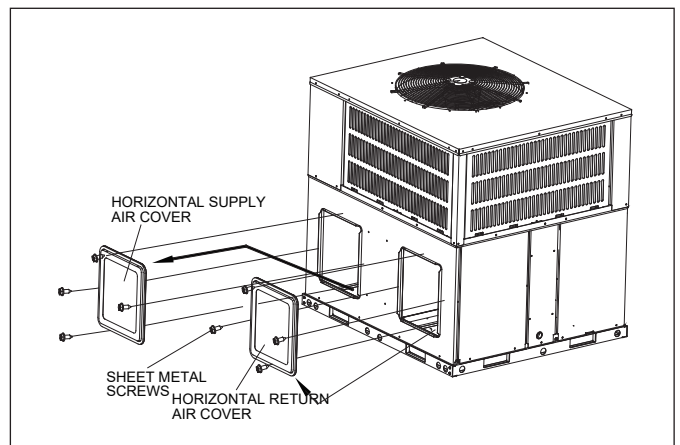

Figure 17

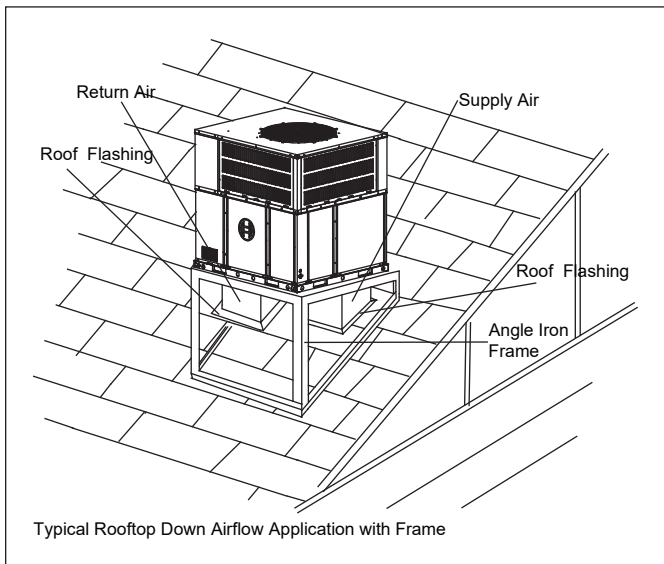

Figure 18 Typical Rooftop Down Airflow Application with Frame

## 7 . Condensate Drain Connection

Unit should be installed in accordance with national and local safety codes, including but not limited to ANSI/NFPA No. 70, local plumbing and wastewater codes and any other applicable codes.

### 7.1 Install Drain Pipe

1. Ensure drain lines do not block access to front of the unit. Minimum clearance of 24 inches is required for filter, coil or blower removal and service access.
2. Make sure unit is leveled or pitched slightly toward primary drain connection so that water will drain completely from the pan.
3. Do not reduce drain line size to less than connection size provided on condensate drain pan.
4. All drain lines must be pitched downward away from the unit at a minimum of 1/8" per foot of line to ensure proper drainage.
5. Do not connect condensate drain line to a closed or open sewer pipe. Run condensate to an open drain or run line to a safe outdoor area.
6. The drain line should be insulated where necessary to prevent sweating and damage due to condensate forming on the outside surface of the line.
7. Make provisions for disconnecting and cleaning of the primary drain line should it become necessary. Install a 2 inch trap in the primary drain line as close to the unit as possible. Make sure that the top of the trap is below connection to the drain pan to allow complete drainage of pan.

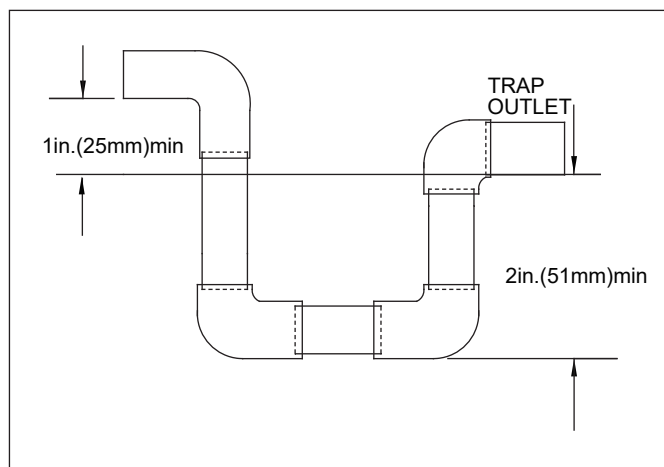

Figure 19

**i** When making drain fitting connections to the drain pan, use a thin layer of Teflon paste, silicone or Teflon tape and install by hand tightening.

**i** When making drain fitting connections to drain pan, do not overtighten. Over tightening fittings can split pipe connections on the drain pan.

## 8 . Air Filter (Not Factory-Installed)

Filters and filter racks are not included with the unit and must be field supplied.

An external filter or other means of filtration must be properly sized for a maximum of 300 feet/min. air velocity or what is recommended for the type of filter installed.

Filter application and placement are critical to airflow, which may affect the heating and cooling system performance. Reduced airflow can shorten the life of the system's major components, such as motor, elements, heat relays, evaporator coil or compressor. Consequently, we recommend that the return air duct system have only one filter location. For systems without a return air filter grill, multiple filter grills can be installed at each of the return air openings.

If adding high efficiency filters or electronic air filtration systems, it is very important that the air flow is not reduced. If air flow is reduced the overall performance and efficiency of the unit will be reduced. It is strongly recommended that a professional installation technician is contacted to ensure such filtration systems are installed correctly.



Do not double filter the return air duct system. Do not filter the supply air duct system. This will change the performance of the unit and reduce airflow.



### WARNING: FIRE HAZARD

Do not operate the system without filters. A portion of the dust suspended in the air may temporarily lodge in the duct runs and at the supply registers. Any circulated dust particles could be heated and charred by contact with the air handler elements. This residue could soil ceilings, walls, drapes, carpets and other articles in the house. Soot damage may occur with filters in place, when certain types of candles, oil lamps or standing pilots are burned.

### NOTE:

**The user needs to use a standard filter that meets the requirements of UL900.  
(Not Factory installed)**

Heat Pump Model	No.	Size Recommended in.
24K/36K	1	16"x10"x1"
48K/60K	1	16"x14"x1"

Table 7

# 9 . Electrical Wiring

Field wiring must comply with the National Electric Code (NEC) and any applicable local ordinance.



## WARNING: ELECTRICAL SHOCK

Disconnect all power to unit before installing or servicing. More than one disconnect switch may be required to de-energize the equipment. Hazardous voltage can cause severe personal injury or death.

## 9.1 Power Wiring

1. It is important that proper electrical power is available for connection to the unit being installed. See the unit nameplate, wiring diagram, and electrical data in the installation instructions for more detailed requirements. Voltage tolerance should not be over 10% from rating voltage.
2. If any of the wiring must be replaced, replacement wiring must be the same type as shown in nameplate, wiring diagram and electrical data sheet.
3. Install a branch circuit disconnect of adequate size to handle starting current, located within sight, and readily accessible to the unit.
4. Electric Heater: If the optional Electric Heat Kit is installed, unit should be equipped with 30~60 amp circuit breakers or fuse. These breaker(s) protect the internal wiring in the event of a short circuit and serve as a disconnect. Circuit breakers installed within the unit do not provide over-current protection of the supply
  - Supply circuit power wiring must be 221 °F minimum copper conductors only. See Table 13 or Table 14 for ampacity, wire size and circuit protector requirements. Supply circuit protective devices may be either fuses or “HACR” type circuit breakers. 1-3/8” knockouts inside the cabinet are provided for connection of power wiring to electric heater.
  - Power wiring is connected to the power terminal block in unit electric cabinet. See Electric Heater Kit Installation Instructions for details.
  - The maximum indoor ambient temperature (T1) for Electric Heat Kit operation is less than 89.6°F. When T1 ≥ 89.6°F, the Electric Heat Kit will be turned off.
5. High voltage and low voltage electricity need to be separated by separate conduits.
6. See wiring diagram located on inside of blower access panel for proper wiring instructions.

## 9.2 Grounding



## WARNING: ELECTRICAL SHOCK

The unit must be permanently grounded. Failure to do so can result in electrical shock causing personal injury or death.

- The unit must be electrically grounded in accordance with local codes or the national electric code.
- Grounding may be accomplished by attaching ground wire(s) to ground lug(s) provided in the unit wiring compartment.

## 9.3 Control Wiring



Low voltage control wiring should not be run in conduit with high voltage wiring. Keep distance between the two conduits per local codes.

- 18 AWG. color-coded low voltage wire should be used for lengths less than 100ft. For wire lengths longer than 100 ft., 16 AWG. wire should be used.
- 7/8” knockout hole should be used to route control wires into the unit.
- After installation, ensure separation of low voltage and high voltage wiring is maintained.

Refer to Figures 20 and 21 for thermostat wiring connections.

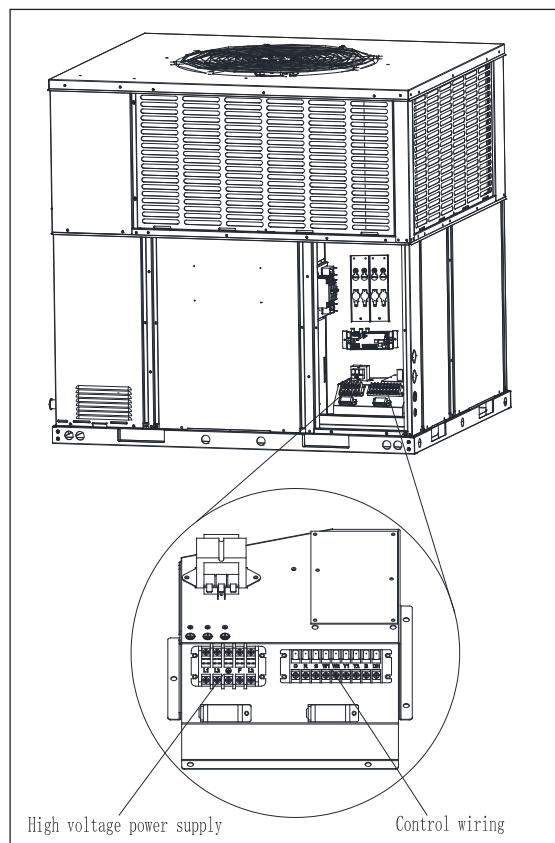
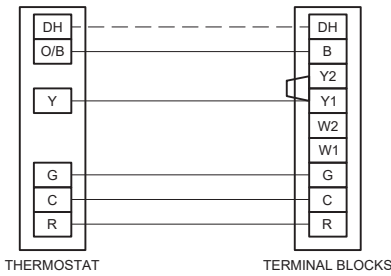
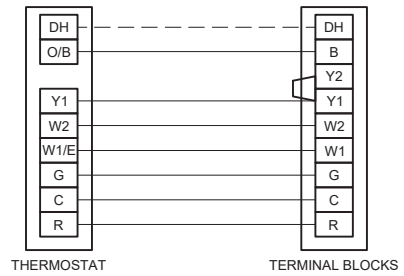

Figure 20

**Wiring for 1H and 1C thermostat**  
(Y1/Y2 jumped for fan control, not related to compressor operation.)



**Wiring for 3H and 1C thermostat**  
(Y1/Y2 jumped for fan control, not related to compressor operation.)



**Wiring for 2H and 1C thermostat**  
(Y1/Y2 jumped for fan control, not related to compressor operation.)

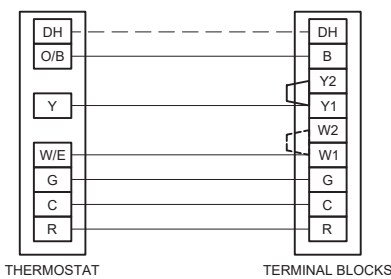

**Wiring for 3H and 2C thermostat**  
(2-COOL here represents 2 stages of fan cooling only, the compressor modulates separately from the fan.)

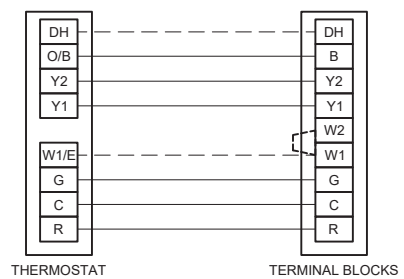

**Wiring for 2H and 2C thermostat**  
(2-COOL here represents 2 stages of fan cooling only, the compressor modulates separately from the fan.)

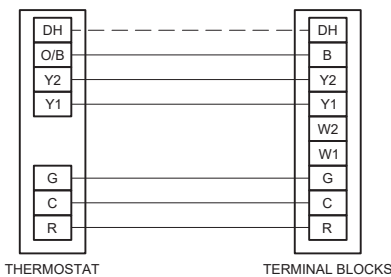

**Wiring for 4H and 2C thermostat**  
(2-COOL here represents 2 stages of fan cooling only, the compressor modulates separately from the fan.)

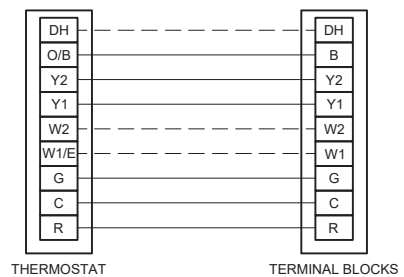

Figure 21 Thermostat Wiring Diagrams

**i** Dh wiring is optional and requires a thermostat with a humidistat. Dh functions as Passive Dehumidification and will downstage the indoor fan to first stage. System will operate according to normal sequence of operations if Dh wiring is absent.

**i** Dashed lines in the above thermostat wiring diagrams refer to optional wiring (wiring for Passive Dehumidification Function and/OR Electric Heat). For thermostat wiring please refer to the Owner's Manual of the thermostat.

**i** B wire must be used with heat pump system only, the reversing valve energizes in heating.

## Control logic

### Indoor unit connector

Connector	Purpose
R	24V Power Connection
C	Common
G	Fan Control
Y1	Low Cooling
Y2	High Cooling
B	Heating Reversing Valve
W1	Stage 1 Electric Heating
W2	Stage 2 Electric Heating
DH	Dehumidification

Table 8

### Outdoor unit connector

Connector	Purpose
C	Common
Y	Cooling
B	Heating Reversing Valve
W	Defrost control

Table 9

## Low Voltage Maximum Wire Length

Table defines the maximum total length of low voltage wiring from the outdoor unit to the indoor unit and to the thermostat.

24 Volts - Wire size	Max. Wire Length
18 AWG	150 Ft.
16 AWG	225 Ft.
14 AWG	300 Ft.

Table 10

## Wire gauge of high voltage system(Single Phase)

Type (Btu/ hour)		24K	36K	48K	60K
Power	Phase	Single			
	Voltage/frequency	208/230VAC, 60 Hz			
Wire gauge	Line quantity	3	3	3	3
	Wire diameter (AWG)	12	10	8	8

Table 11

## Wire gauge of high voltage system(Three Phase)

Type (Btu/ hour)		24K	36K	48K	60K
Power	Phase	Three			
	Voltage/frequency	208/230VAC, 60 Hz			
Wire gauge	Line quantity	4	4	4	3
	Wire diameter (AWG)	12	12	10	10

Table 12

Size(Tons)	Voltage Phase Frequency	Compressors	OD Fan Motors (each)	Supply Blower Motor		Unit Circuit	
		RLA	FLA	FLA	LRA	MCA1(Amps)	Max Fuse/ Breaker Size(Amps)
24K-18SEER	208/230- 1-60	16	2.1	3.8	/	25.90	40
36K-18SEER		19	2.1	3.8	/	29.65	45
48K-18SEER		23	2.3	5.4	/	38.95	60
60K-18SEER		27	2.3	5.4	/	41.45	60
60K-18SEER	208/230- 3-60	15	2.3	5.4	/	26.45	45

Table 13 Electrical Data Without Electric Heat



**WARNING: ELECTRICAL SHOCK**

Label all wiring prior to disconnection when servicing controls. Wiring errors can cause improper and dangerous operation. Verify proper operation after servicing.

Heater Circuit					
Model	kW	Stages	Amps	MCA <sup>1</sup> (Amps)	Max Fuse <sup>2</sup> / Breaker <sup>3</sup> Size (Amps)*
AC-I-05-EAH-PKG	3.8/5	1	18.2/20.8	23/26	25/30
AC-I-07-EAH-PKG	5.6/7.5	1	27.9/31.9	35/40	35/40
AC-I-10-EAH-PKG	7.5/10	1	36.3/41.7	46/53	50/60
AC-I-15-EAH-PKG	5.6+5.6/7.5+7.5	2	27.9+27.9/31.9+31.9	35+35/40+40	35+35/40+40
AC-I-20-EAH-PKG	7.5+7.5/10+10	2	36.3+36.3/41.7+41.7	46+46/53+53	50+50/60+60

Table 14 Electrical Data With Electric Heat

1. Minimum Circuit Ampacity.
2. Maximum Over Current Protection per Standard UL 1995.
3. Fuse or HACR circuit breaker size installed at factory or field installed.

\* Max Fuse/Breaker Sizes listed in Table 14 are for electric heater ONLY. DOES NOT include breaker size for the unit (refer to Table 13).



**WARNING: ELECTRICAL SHOCK / FIRE HAZARD**

Any power supply and circuits must be wired and protected in accordance with local electrical codes.

## 10 . Start Up

1. Ensure Sections 4, 5, 6, 7, and 8 have been completed.
2. Set System Thermostat to OFF.

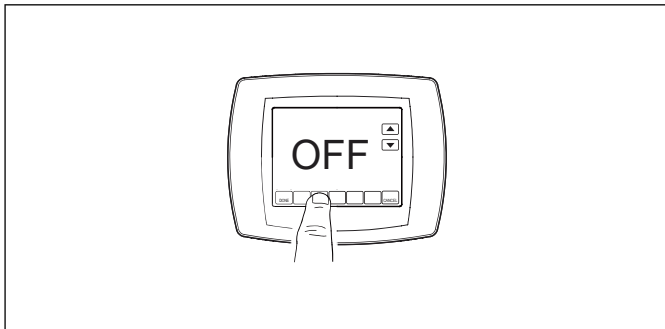

Figure 22

3. Turn on disconnect to apply power to the indoor and outdoor units.

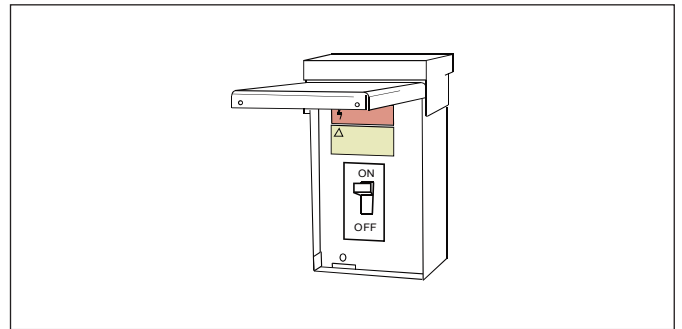

Figure 23

4. Wait one (1) hour before starting the unit if compressor crankcase heater is used and the outdoor ambient temperature is below 70 °F.



Figure 24

5. Set system thermostat to ON.

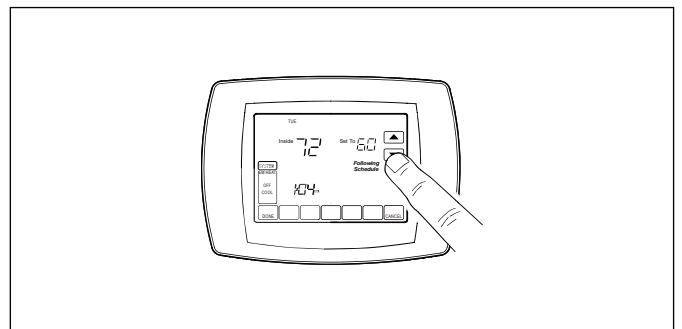

Figure 25

# 11 . System Charge Adjustment

**i** The unit comes precharged from the factory with 12-9 lb-oz of refrigerant. Please measure superheat and subcooling, and add or remove refrigerant accordingly.

## 11.1 Charging: Weigh-In Method

Weigh-in method is recommended for the initial installation, or anytime a system charge is being replaced. Weigh-in method can also be used when power is not available to the equipment site or operating conditions (indoor/outdoor temperatures) are not in range to verify with the subcooling charging method.

Heat Pump Model	oz(kg)
24K-18SEER	102.3oz(2.9kg)
36K-18SEER	102.3oz(2.9kg)
48K-18SEER	169.3oz(4.8kg)
60K-18SEER	169.3oz(4.8kg)

Table 15

## 11.2 Subcooling Charging and Refrigerant Adjustment In Cooling (Above 55°F Outdoor Temp.)

### 1. Check the outdoor ambient temperatures.

Subcooling (in cooling mode) is the only recommended method of charging above 55°F outdoor ambient temperatures. For outdoor ambient temperatures below 55°F, use weigh-in charge method.

**i** It is important to return in the spring or summer to accurately charge the system in the cooling mode when outdoor ambient temperature is above 55°F.

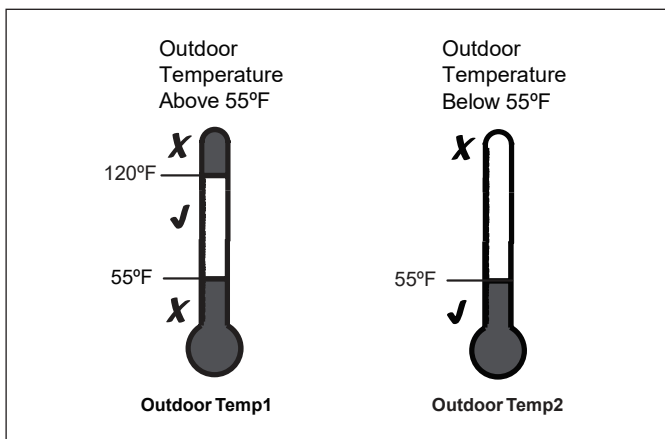

Figure 26

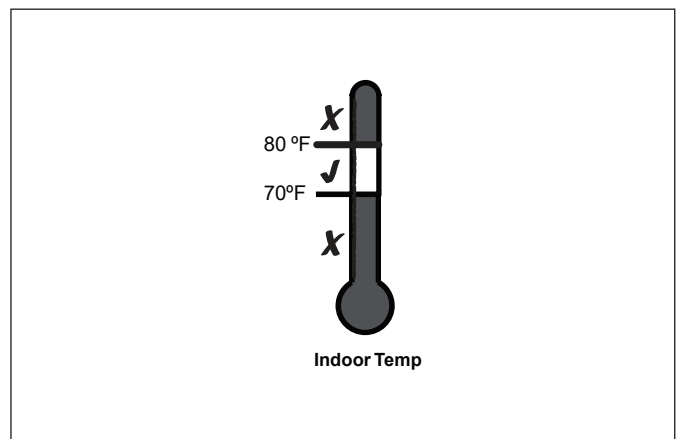

Figure 27

For best results the indoor temperature should be kept between 70°F to 80°F.

**2. Stabilize the system.**

2. Start "forced cooling" mode. Start the system in cooling mode, press and hold "SET" button until the symbol "dC" displayed. Once enter "forced cooling mode", symbol "dC" and the current frequency will be displayed alternately in "forced cooling" mode. "Forced cooling" mode will automatically exit after 60 minutes or press and hold "SET" quit "forced cooling" mode manually.

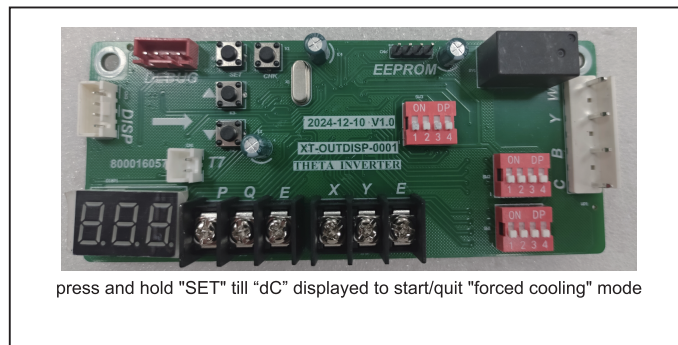

Figure 28



After a twenty (20) minute stabilization period operating at 100% capacity (60 Hertz ), maintain continuous operation while adjusting refrigerant charge. After adjusting, operate system for a minimum of five (5) minutes for system to stabilize, otherwise repeat step 3.

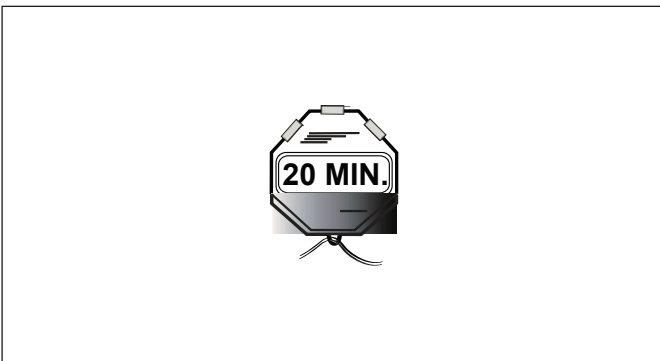

Figure 29

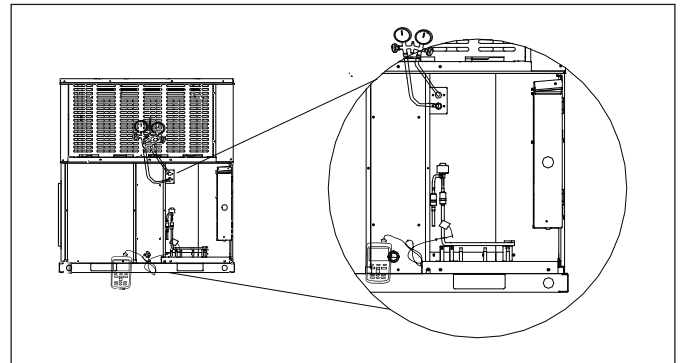

Figure 30

**3. Calculate subcooling value on liquid line (According to Table 16)**

- Measured Liquid Line Temp. = \_\_\_\_\_ °F
- Measured Liquid Line Pressure = \_\_\_\_\_ PSIG
- Calculate subcooling value = \_\_\_\_\_ °F



Ensure the temperature sampling position as shown above.



If calculated subcooling value is lower than the design subcooling value (Table 17), please add refrigerant. Repeat steps 2 through 4.

Liquid Line Temp(°F)	Final Subcooling(°F)							
	6	7	8	9	10	11	12	13
	Liquid Gauge Pressure(PSI)							
55	177	180	183	186	189	193	196	199
60	193	196	199	202	206	209	213	216
65	209	213	216	220	223	227	230	234
70	227	230	234	238	241	245	249	253
75	245	249	253	257	261	265	269	273
80	265	269	273	277	281	285	290	294
85	285	290	294	298	303	307	312	316
90	307	312	316	321	325	330	335	340
95	330	335	340	345	350	355	360	365
100	355	360	365	370	375	380	385	390
105	380	385	390	396	402	407	413	418
110	407	413	418	424	429	435	441	447
115	435	441	447	453	459	465	471	477
120	465	471	477	483	490	496	502	509
125	496	502	509	515	522	529	535	542

Table 16 R-32 Refrigerant Chart - Final Subcooling

Heat Pump Model	Design Subcooling
24K/36K/48K/60K	12°F±4°F

Table 17

**4. Adjust refrigerant level to attain proper gauge pressure.**

**i** Add refrigerant if the subcooling reading from Table 16 is lower than the designed value (Table 17).

- Connect gauges to refrigerant bottle and unit as illustrated (Figure 31).
- Purge all hoses.
- Open tank.
- Stop adding refrigerant when subcooling matches the charging chart (Table 16) Final Subcooling value.

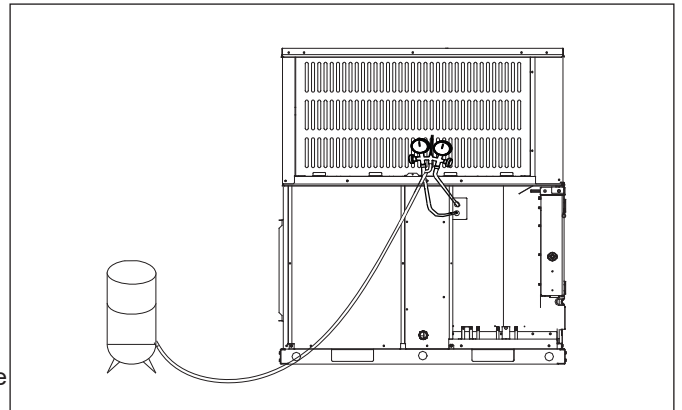

Figure 31

**i** Recover refrigerant if the subcooling reading from Table 16 is higher than the designed value (Table 17).

**5. Stabilize the system.**

- Wait 5 minutes for the system condition to stabilize between adjustments.

**i** When the subcooling matches the chart, the system is properly charged.

- Remove gauges.
- Replace service port caps to prevent leaks. Tighten finger tight plus an additional 1/6 turn.

**7. Record System Information for reference (Table 22). Record system pressures and temperatures after charging is complete.**



The subcooling also can be calculated by pressing check button after getting T3 and T7 temperatures (refer to table 26).

Description	Value
Outdoor model number	
Measured Outdoor Ambient	°F
Measured Indoor Ambient	°F
Check Condenser Outlet Temp.(T3L)	°F
Check Condenser Temp.(T3)	°F
Calculate subcooling value =T3-T3L	°F

Table 19

## 12 . Refrigerant Charge and Room Area Limitations

In UL/CSA 60335-2-40, R32 refrigerant is classified as class A2L, which is mildly flammable. Therefore, R32 refrigerant would limit the area of the rooms being served.

Similarly, the total amount of refrigerant in the system shall be less than or equal to the allowable maximum refrigerant charge. The allowable maximum refrigerant charge depends on the area of the rooms being served by the system.



The nouns in this section are explained as follows:

$m_c$ : The actual refrigerant charge in the system.

$A$ : the actual room area where the appliance is installed.

$A_{min}$ : The required minimum room area.

$m_{max}$ : The allowable maximum refrigerant charge in a room.

$Q_{min}$ : The minimum circulation airflow.

$Anv_{min}$ : The minimum opening area for connected rooms.

$TA_{min}$ : The total area of the conditioned space (For appliances serving one or more rooms with an air duct system).

$TA$ : The total area of the conditioned space connected by air ducts.

### 12.1 The room area calculation requirements



The space considered shall be any space which contains refrigerant-containing parts or into which refrigerant could be released.

The room area ( $A$ ) of the smallest, enclosed, occupied space shall be used in the determination of the refrigerant quantity limits.

For determination of room area ( $A$ ) when used to calculate the refrigerant charge limit, the following shall apply.

The room area ( $A$ ) shall be defined as the room area enclosed by the projection to the base of the walls, partitions and doors of the space in which the appliance is installed.

Spaces connected by only drop ceilings, ductwork, or similar connections shall not be considered a single space.

Units mounted higher than 70-55/64 inches and spaces divided by partition walls that are no higher than 62-63/64 inches shall be considered a single space.

Rooms on the same floor and connected by an open passageway between the spaces can be considered a single room when determining compliance to  $A_{min}$ , if the passageway complies with all of the following.

- 1) It is a permanent opening.
- 2) It extends to the floor.
- 3) It is intended for people to walk through.

The area of the connected rooms, on the same floor, connected by permanent opening in the walls and/or doors between occupied spaces, including gaps between the wall and the floor, can be considered a single room when determining compliance to  $A_{min}$ , provided all of the following conditions are met as Figure 32.

#### 1) Low level opening

1. The opening shall not be less than  $Anv_{min}$  in Table 20.
2. The area of any openings above 11-13/16 inches from the floor shall not be considered in determining compliance with  $Anv_{min}$ .
3. At least 50 % of the opening area of  $Anv_{min}$  shall be below 7-7/8 inches from the floor.
4. The bottom of the opening is not more than 3-15/16 inches from the floor.
5. The opening is a permanent opening that cannot be closed.
6. For openings extending to the floor the height shall not be less than 25/32 inches above the surface of the floor covering.

#### 2) High level opening

1. The opening shall not be less than 50 % of  $Anv_{min}$  in Table 20.
2. The opening is a permanent opening that cannot be closed.
3. The opening shall be at least 59 inches above the floor.
4. The height of the opening is not less than 25/32 inches.

#### 3) Room size requirement

1. The room into which refrigerant can leak, plus the connected adjacent room(s) shall have a total area not less than  $A_{min}$ .  $A_{min}$  is shown in Table 22.
2. The room area in which the unit is installed shall be not less than 20 %  $A_{min}$ .  $A_{min}$  is shown in Table 22.



The requirement for the second opening can be met by drop ceilings, ventilation ducts, or similar arrangements that provide an airflow path between the connected rooms.

The minimum opening for natural ventilation ( $Anv_{min}$ ) in connected rooms is related to the room area ( $A$ ), the actual refrigerant charge of refrigerant in the system ( $m_c$ ), and the allowable MAXIMUM REFRIGERANT CHARGE in the system ( $m_{max}$ ),  $Anv_{min}$  can be determined according to Table 21.

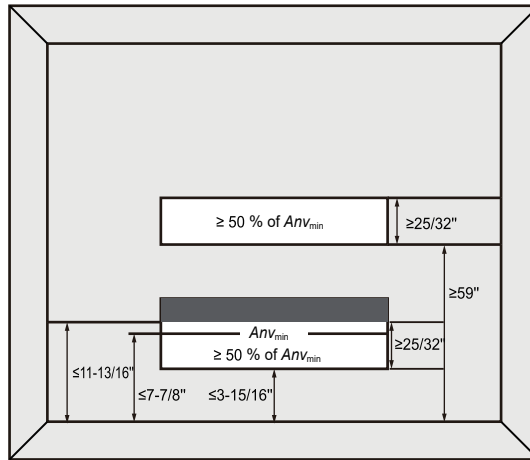

Figure 32 Opening Conditions for Connected Rooms

The minimum opening area for connected rooms

A		$m_c$		$m_{max}$		$Anv_{min}$	
ft <sup>2</sup>	m <sup>2</sup>	lb-oz	kg	lb-oz	kg	ft <sup>2</sup>	m <sup>2</sup>
100	10	17-3	7.8	6-10	3.0	1.3	0.13
110	11	17-3	7.8	7-5	3.3	1.2	0.12
120	12	17-3	7.8	8-0	3.6	1.1	0.11
130	13	17-3	7.8	8-10	3.9	1.0	0.10
140	14	17-3	7.8	9-5	4.2	1.0	0.10
150	14	17-3	7.8	10-0	4.5	0.9	0.09
160	15	17-3	7.8	10-10	4.8	0.8	0.08
170	16	17-3	7.8	11-5	5.1	0.7	0.07
180	17	17-3	7.8	12-0	5.4	0.6	0.06
190	18	17-3	7.8	12-10	5.7	0.5	0.05
200	19	17-3	7.8	13-5	6.0	0.5	0.05
210	20	17-3	7.8	14-0	6.3	0.4	0.04
220	21	17-3	7.8	14-10	6.6	0.3	0.03
230	22	17-3	7.8	15-5	6.9	0.2	0.02
240	23	17-3	7.8	16-0	7.2	0.1	0.01
250	24	17-3	7.8	16-10	7.5	0.1	0.01
260	25	17-3	7.8	17-5	7.8	0.0	0.00

Table 20

Note: Take the  $m_c = 17$  lb 3 oz as an example.

For appliances serving two or more rooms with an air duct system, The room area calculation shall be determined based on the total area of the conditioned space ( $TA$ ) connected by ducts taking into consideration that the circulating airflow distributed to all the rooms by the appliance integral indoor fan will mix and dilute the leaking refrigerant before entering any room.

## 12.2 The allowed maximum refrigerant charge and required minimum room area

If the fan incorporated in the appliance is continuously operated or operation is initiated by a REFRIGERANTDETECTION SYSTEM with a sufficient CIRCULATION AIRFLOW rate, the allowable maximum refrigerant charge ( $m_{max}$ ) and the required minimum room area ( $A_{min}/T_{Amin}$ ) is shown in Table 21 and Table 22.

The allowable maximum refrigerant charge

A/TA		$m_{max}$		A/TA		$m_{max}$	
ft <sup>2</sup>	m <sup>2</sup>	lb-oz	kg	ft <sup>2</sup>	m <sup>2</sup>	lb-oz	kg
30	3	2-0	0.9	150	14	10-0	4.5
40	4	2-10	1.2	160	15	10-10	4.8
50	5	3-5	1.5	170	16	11-5	5.1
60	6	4-0	1.8	180	17	12-0	5.4
70	7	4-10	2.1	190	18	12-10	5.7
80	8	5-5	2.4	200	19	13-5	6.0
90	9	6-0	2.7	210	20	14-0	6.3
100	10	6-10	3.0	220	21	14-10	6.6
110	11	7-5	3.3	230	22	15-5	6.9
120	12	8-0	3.6	240	23	16-0	7.2
130	13	8-10	3.9	250	24	16-10	7.5
140	14	9-5	4.2	260	25	17-5	7.8

Table 21

The required minimum room area

$m_c$		$A_{min}/TA_{min}$		$m_c$		$A_{min}/TA_{min}$	
lb-oz	kg	ft <sup>2</sup>	m <sup>2</sup>	lb-oz	kg	ft <sup>2</sup>	m <sup>2</sup>
2-2	1.0	33.1	3.1	10-2	4.6	152.1	14.2
2-9	1.2	39.7	3.7	10-9	4.8	158.7	14.8
3-0	1.4	46.3	4.4	11-0	5.0	165.3	15.4
3-7	1.6	52.9	5.0	11-7	5.2	171.9	16.0
3-15	1.8	59.5	5.6	11-14	5.4	178.5	16.6
4-6	2.0	66.1	6.2	12-5	5.6	185.1	17.2
4-13	2.2	72.7	6.8	12-12	5.8	191.7	17.9
5-4	2.4	79.3	7.4	13-3	6.0	198.4	18.5
5-11	2.6	86.0	8.0	13-10	6.2	205.0	19.1
6-2	2.8	92.6	8.7	14-1	6.4	211.6	19.7
6-9	3.0	99.2	9.3	14-8	6.6	218.2	20.3
7-0	3.2	105.8	9.9	14-15	6.8	224.8	20.9
7-7	3.4	112.4	10.5	15-6	7.0	231.4	21.5
7-15	3.6	119.0	11.1	15-14	7.2	238.0	22.2
8-6	3.8	125.6	11.7	16-5	7.4	244.6	22.8
8-13	4.0	132.2	12.3	16-12	7.6	251.2	23.4
9-4	4.2	138.8	12.9	17-3	7.8	257.9	24.0
9-11	4.4	145.5	13.6				

Table 22

The minimum circulation airflow

$m_c$		$Q_{min}$		$m_c$		$Q_{min}$	
lb-oz	kg	CFM	m <sup>3</sup> /h	lb-oz	kg	CFM	m <sup>3</sup> /h
2-2	1.0	59	100	10-2	4.6	275	467
2-9	1.2	71	121	10-9	4.8	287	488
3-0	1.4	83	141	11-0	5.0	298	506
3-7	1.6	95	161	11-7	5.2	310	527
3-15	1.8	107	182	11-14	5.4	322	547
4-6	2.0	119	202	12-5	5.6	334	567
4-13	2.2	131	223	12-12	5.8	346	588
5-4	2.4	143	243	13-3	6.0	358	608
5-11	2.6	155	263	13-10	6.2	370	629
6-2	2.8	167	284	14-1	6.4	382	649
6-9	3.0	179	304	14-8	6.6	394	669
7-0	3.2	191	325	14-15	6.8	406	690
7-7	3.4	203	345	15-6	7.0	418	710
7-15	3.6	215	365	15-14	7.2	430	731
8-6	3.8	227	386	16-5	7.4	442	751
8-13	4.0	239	406	16-12	7.6	454	771
9-4	4.2	251	426	17-3	7.8	466	792
9-11	4.4	263	447				

Table 23



The allowable maximum refrigerant charge of the Table 21 or the required minimum room area of the Table 22 is available only if the following conditions are met:

Minimum velocity of 3.28 ft/s, which is calculated as the indoor unit airflow divided by the nominal face area of the outlet. the grill area shall not be deducted.

Minimum airflow rate must meet the corresponding values in Table 23, which is related to the actual refrigerant charge of the system ( $m_c$ ).

R32 refrigerant leakage sensor is configured.



The maximum refrigerant limit described above applies to unventilated areas. If adding additional measures, such as areas with mechanical ventilation or natural ventilation, the maximum refrigerant charge can be increased or the minimum room area can be reduced. The R32 refrigerant leakage sensor is configured for the indoor unit and meets the incorporated circulation airflow requirements. The maximum refrigerant charge or minimum room area can be determined according to Table 21 or Table 22.



If the actual room area, air outlet height, and refrigerant charge amount are not reflected in the above table, more severe cases need to be considered according to the data in the Table 20, 21, 22, 23.

● Installation scheme flow chart

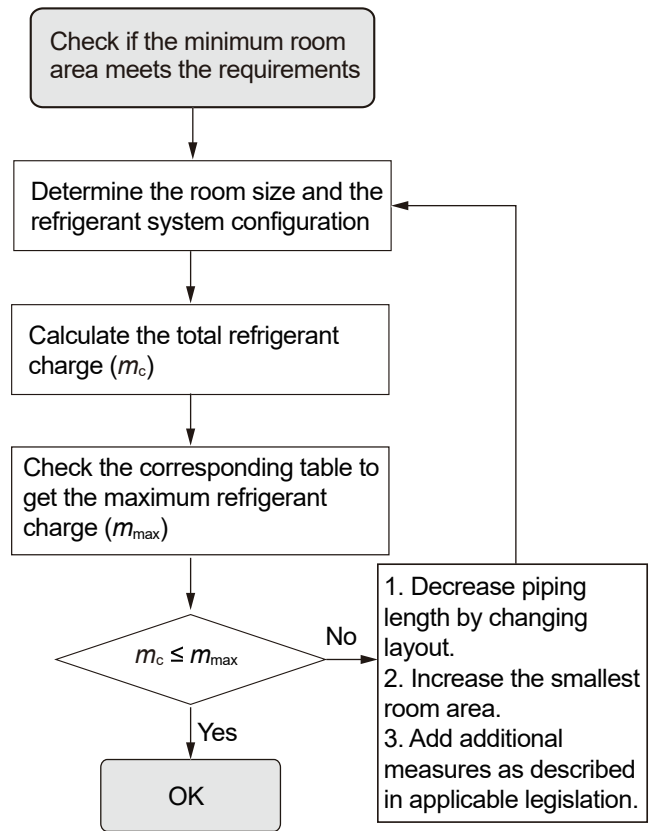

Figure 33

## 13 . Replace the refrigerant concentration sensor

Refrigerant concentration sensor specifications:

MODEL: MGS-11-R32

MINIMUM LIFETIME: 10 YEARS

It needs to be replaced with the same model. If in doubt, please consult the manufacturer for assistance.

- 1.Remove the middle panel and right panel, and remove the sensor cable from the electric control panel.
- 2.Take out the volute motor parts, unscrew the sensor screws, and take out the sensor.
- 3.Replace the new refrigerant concentration sensor, fix it on the original sheet metal, insert the wire into the electric control board and fix the wire, and then install the volute motor parts, the middle panel and the right panel.

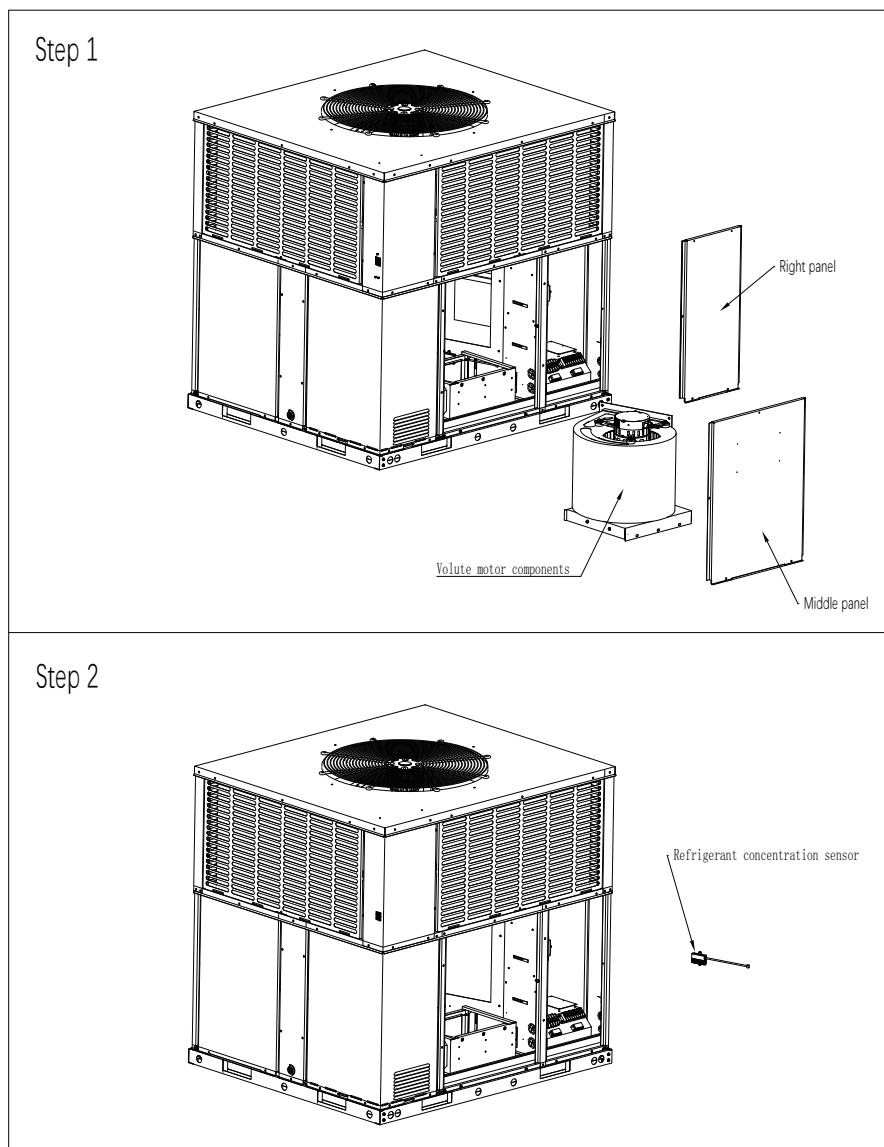

Figure 34



### R32 Leakage Detection Function:

The function utilizes a R32 refrigerant sensor to detect the R32 concentration. Terminal F is reserved for connecting buzzer if needed.

When R32 leaks and the concentration is greater than or equal to 10%, the unit operates as follows:

1. Cut off the power supply to the thermostat and stop the compressor from running.
2. The electric heating kit will be closed.
3. The internal fan will be forced to open.
4. A high voltage is generated between the F terminal and F2 terminal, and the buzzer is on.

## 14 . System Operation and Troubleshooting

### 14.1 Control Logic Description

- The Inverter system adopts the same 24VAC control as any conventional heat pump.
- The compressor's speed is controlled based on coil pressures monitored by the unit's pressure transducer. To ensure stable and adequate capacity, the compressor speed will modulate relative to evaporator pressure during cooling operation and relative to condensing pressure during heating operation.

### 14.2 Sensors and valves

T3: Outdoor Coil Temperature

- High temperature protection
- Outdoor fan control (Cooling mode)
- Defrost control (Heating mode)

T4: ODU Ambient Temperature

- Maximum compressor frequency limitation
- Defrosting condition (Heating mode)
- Outdoor fan control (Heating mode)

T5: Compressor Discharge Temperature

- High discharge temperature / Low superheat protection
- Electronic Expansion Valve (EEV) control

T7: Control board Heat Pipe Temperature

- Control board Anti-Condensed

Tfin: IPM Radiator Temperature

- High IPM temperature protection

PT: Pressure Transducer

- Detect evaporating pressure in cooling mode and condensing pressure in heating mode.
- Compressor frequency control
- Electronic Expansion Valve (EEV) control
- High pressure protection (heating mode)
- Low pressure protection (cooling mode)

Pressure equalizer Valve (PEV)

Balance the pressure of the system before compressor start up

Reversing valve

Used to switch the refrigerant flow direction between cooling and heating mode

### 14.3 Accelerated Cooling/Heating

The dip switch SW1-4 and SW3-4 are set to OFF position by default. If switch SW1-4 is set to ON, the target coil temperature will reduce in cooling mode, while switch SW3-4 is set to ON, the target coil temperature will increase in heating mode. Accelerated cooling/heating function improves dehumidification capacity in cooling mode and increases unit capacity.

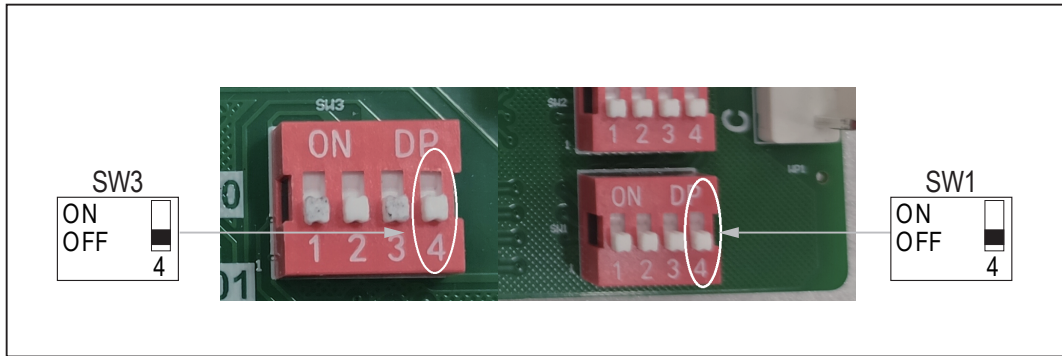

Figure 35

## 14.4 Defrost Description

### Automatic Defrost Control Function.

The function monitors outdoor coil temperature (T3) and the ambient temperature (T4) to determine whether to defrost or not.

One of the following conditions should be met to run a defrost cycle:

1. The difference between the outdoor ambient temperature (T4) and the outdoor coil temperature (T3) is called Delta T. When  $T4 \geq 19^{\circ}\text{F}$ , the compressor has run for 60 minutes or under PI control for 15 minutes, and  $T3 < 30^{\circ}\text{F}$ , as well as  $\text{Delta } T < 46^{\circ}\text{F}$  lasts for 3 minutes, the unit will run a defrost cycle automatically.
2. When the compressor has run for 120 minutes under the low ambient temperature between  $14^{\circ}\text{F}$  and  $19^{\circ}\text{F}$ , and  $T3 < 5^{\circ}\text{F}$  or the decreasing of T3 is beyond  $5^{\circ}\text{F}$ , the unit will run a defrost cycle automatically.
3. When  $T4 \leq 14^{\circ}\text{F}$ : a) the compressor has run for 90 minutes and  $T3 \leq -13^{\circ}\text{F}$ , or b) the compressor has run for 90 minutes and the decreasing of T3 is beyond  $5^{\circ}\text{F}$ , or c) the compressor has run for 360 minutes, the unit will run a defrost cycle automatically.

### Minimum Run Time (MRT) Defrost.

The MRT Defrost function is based on outdoor ambient temperature (T4), it works when T3 misjudged by chance. One of the following conditions should be met to run a defrost cycle:

- a)  $\text{MRT} \geq 3.5$  hours and  $T4 < 23^{\circ}\text{F}$
- b)  $\text{MRT} \geq 2$  hours and  $23^{\circ}\text{F} \leq T4 < 42^{\circ}\text{F}$
- c)  $\text{MRT} \geq 50$  minutes and the last defrost time  $\geq 7$  minutes

### Low Saturated Discharge Pressure (SDP) Defrost.

It works when T3 misjudged by chance. When the unit has run for 20 minutes under the ambient condition:  $14^{\circ}\text{F} \leq T4 < 28^{\circ}\text{F}$ , monitor the Saturated Discharge Pressure (SDP) to judge whether it drops below  $82^{\circ}\text{F}$  for running a defrost or not.

### Fixed Time Defrost.

When the dip switch SW2-1 is set to ON, the Fixed Time Defrost Mode is activated. For different geographical and ambient conditions, set dip switch SW2-2 to select the fix time for defrost cycle. SW2-1 and SW2-2 are set to OFF by default.

### Accelerated Defrost.

Heating operating time is reduced by 10% and Defrost time is extended for 60 seconds. Valid only for Fixed Time Defrost and Minimum Run Time Defrost.

### Manual Defrost.

Press and hold the button “▼” on the display board till the symbol “dF” shows (“dF” and the compressor frequency will be displayed alternately). The unit must have been operating in heating mode for at least 5 minutes. Defrost will terminate automatically, after which the display board will show the compressor speed (Hz).

### O/B Signal.

Thermostat which has O/B signal, should check the default setting. The dip switch SW2-4 is set to OFF by factory default, which requires a B signal call from the thermostat in heating mode. While SW2-4 is set to ON, the unit will operate cooling mode with an O signal from thermostat.

Defrost will terminate once the outdoor coil temperature (T3) reaches 64°F for a period of 1 minute or defrost time has exceeded 8 minutes.

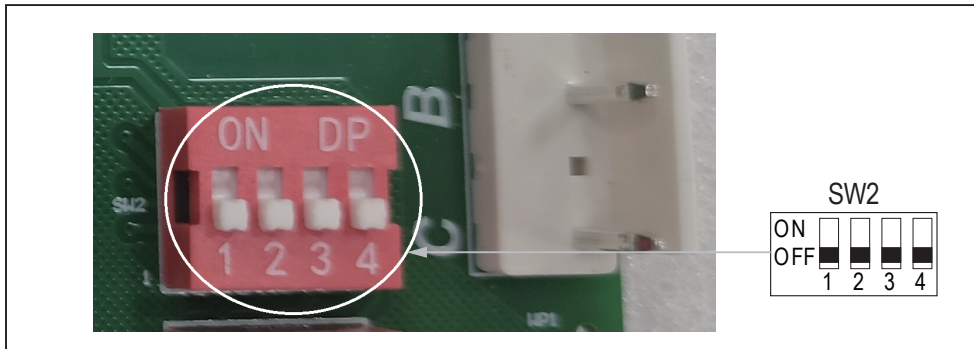

Figure 36

## 14.5 Compressor Crankshaft Heater Control Function

1. Meet one of the following conditions to start the crankcase heater
  - 1.1 Discharge temperature  $T5 < 73.4^{\circ}\text{F}$  and defrost is turned on
  - 1.2 Discharge temperature  $T5 < 73.4^{\circ}\text{F}$  when powered on for the first time.
  - 1.3 The power off time is longer than 3 hours or more than 2 hours when powered on for the first time. And at this time  $T4 < 50^{\circ}\text{F}$  and the discharge temperature  $T5 < 73.4^{\circ}\text{F}$ .
2. Exit conditions:  
Discharge temperature  $T5 \geq 82.4^{\circ}\text{F}$ .

## 14.6 Operation of Reversing Valve

- ▶ The reversing valve is energized in heating mode and de-energized in cooling mode.



During the heating signal of the first operation, the unit will run in the cooling state for about 1 minute, accumulating pressure for reversing the reversing valve.

## 14.7 Defensive Function

- Temperature protection of outdoor coil in cooling mode (T3)
  1. If  $T3 >$  Maximum set temperature, the system stops for protection.
  2. If  $T3 <$  the set recovery temperature value, the system restarts.

Note: Please consult the supplier for maximum temperature and recovery temperature.

- Exhaust temperature protection (T5)
  1. In cooling or heating mode, if the temperature is higher than the set maximum value, the system will stop for protection.
  2. In cooling or heating mode, if the temperature is lower than the set recovery temperature, the system will restart.

Note: Please consult the supplier for maximum temperature and recovery temperature.

- IPM module (inverter) protection (TF)
  1.  $TF \geq$  the highest judgment value C. If the outdoor fan does not reach the highest level at this time, the fan speed will be increased one by one. At this time, the compressor frequency is not limited. If the outdoor fan is the highest fan speed, the current frequency is the highest allowable operating frequency.
  2.  $TF \geq$  the highest judgment value B, the compressor reduces the frequency successively.
  3.  $TF \geq$  the highest judgment value A, the compressor stands by abnormally.
  4.  $TF \leq$  the highest judgment value D, the system restarts.

Note: The highest judgment value A/B/C/D are all parameters set in the program. Please consult the supplier for specific values.

**Table 24**

Code	Failure and Protection
E1	Communication error(indoor unit)
E2	T1 sensor error
E3	T2 sensor error
E4	R32 sensor error
E6	Refrigerant leakage error
E8	Fan motor error(indoor unit)
E9	Communication fault of wire control
EE	EEPROM failure (indoor unit)
F0	Communication failure(outdoor unit)
F2	T6A sensor fault
F3	T6B sensor fault
F4	T4 outdoor ambient temp sensor error
F5	T5 exhaust temp sensor error
F6	T3 condensing temp sensor error
F7	T7 temp sensor error
F8	T7 temp sensor error in detecting condensate risks
F9	AC overvoltage/undervoltage protection
FA	EEPROM failure (outdoor unit)
FB	EEPROM failure of driver chip
FC	IPM modular sensor error
FD	HLP pressure sensor failure
FE	T3 or T5 sensor disconnect error
FF	HPS condenser sensor disconnected

P1	High pressure switch error
P2	Low pressure protection
P3	Inverter overcurrent protection
P4	T5 exhaust temp sensor high temp protection
P5	T3 condenser sensor high temp protection(In cooling mode)
P6	IPM protection
P7	T2 freeze protection
P8	IPM high temperature protection (Tf)
P9	DC fan motor error
PC	Wet operation error
PA	DC fan 2 fault (available on some models)
PD	High pressure abnormal error(In heating mode)
H0	Communication fault of master board and driver chip
H1	T3 sensor high temperature error(In cooling mode) (3 times P5 error within 180mins)
H2	High pressure switch error(3 times P1 error within 150 mins)
H3	High pressure abnormal in heating mode (3 times PD error within 180 mins)
H4	IPM modular high temp error (3 times P8 within 120 mins)
H5	Low pressure error (5 times P2 within 240 mins)
H6	Discharge temperature abnormal error(3 times P4 within 100 mins)
H7	Wet operation error (3 times PC within 200 mins)
H8	T3 condenser sensor disconnect error (3 times FE within 120 mins)
H9	139 chip communication failure with 24T (some models)
HC	Discharge temp sensor disconnect error(3 times FE within 180 mins)
HE	Condensate error(3 times F8 within 60 mins)
L0	DC cable bus low voltage protection
L1	DC cable bus high voltage protection
LA	Frequency limitation by voltage
LB	Frequency limitation or decline by high pressure
LC	Frequency limitation by condenser temp
LD	Frequency limitation by discharge temp
LE	Frequency limitation by IPM modular high temp
LF	Frequency limitation by current
d0	Oil return
df	Defrost
dC	Force cooling
ATL	Overtemperature protection
PRH	Crankcase heater warming up (the outdoor unit will start soon about 1 hour)

## 14.8 Capacity model selection

System software will recall performance setting parameters according to the DIP switch selection. The DIP should be set according to the matched IDU.

Mode	SW3-2	SW3-3	Remark
2 Ton(24K)	OFF	OFF	
3 Ton(36K)	OFF	ON	
4 Ton(48K)	ON	OFF	
5 Ton(60K)	ON	ON	

Table 25

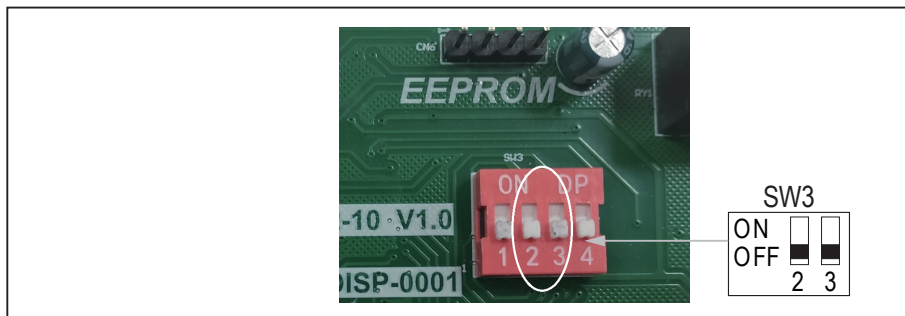

Figure 37

## 14.9 SW1 DIP SWITCH Description

The dip switch SW1-1 is set to OFF, the unit should be controlled by a 24V thermostat. For RS485 communication mode, set SW1-1 to ON. The RS485 communication mode is only valid on the manufacturer approved match indoor unit, outdoor system and manufacturer supplied RS485 communicative thermostat which is optional. The benefits of RS485 communication Mode:

- Modulate compressor speed by indoor temp. to achieve higher energy efficiency and comfort
- Error code display on thermostat
- Allow end user to remotely control system via manufacturer's app

The dip switch SW1-2 is for selection of display temp.& pressure unit.

The dip switch SW1-3 is for switching between Cool Only(AC) and Heat Pump(HP).

	SW1-1	SW1-2	SW1-3
ON	RS485	°C & MPa	AC
OFF	24V thermostat (Factory default)	°F & PSI (Factory default)	HP (Factory default)

Table 26

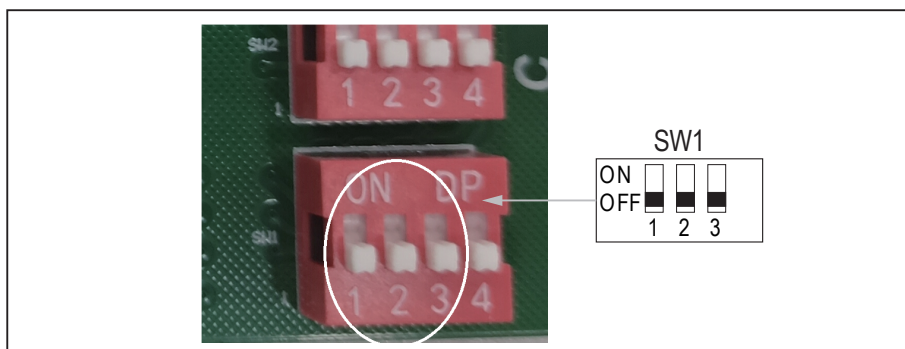

Figure 38

## 14.10 Parameter Point Check Table

- To display system parameters, press the "CHK"(K1) button to run through the series of parameters available. The first time you press the "CHK" button, it will display the NUM of parameter, and after 1 second it will display the value of the parameter. If you press the "CHK" button again, it will go to next NUM of parameter. (Refer to Table 30).
- Refer to the picture below for check button location on the display board.
- ▲ : check button、 and set the parameter "+"
- ▼ : check button、 and set the parameter "-"

**Table 27**

Check Table			
NUM	Display content	20	AC current (A; Actual value)
00	Unit type: 0 = top discharge unit 1 = side discharge unit 2 = rooftop unit	21	Compressor current
01	Outdoor power (Model)	22	Oil output (CC; Actual value)
02	Running mode (0: Standby mode; 2: In cooling mode; 3: In heating mode)	23	T1 indoor ambient temp(°F; Actual value)
03	Target frequency (Hz; Actual value)	24	T2 indoor evaporator temp(°F; Actual value)
04	Actual frequency (Hz; Actual value)	25	Concentration value
05	Running frequency (Hz; Actual value)	26	Enter PI control sign (0 or 1)
06	T3 condensing temp (°F; Actual value)	27	Enter defrosting type
07	T4 outdoor ambient temp(°F; Actual value)	28	Test mode (1-40; Mode gear)
08	T5 exhaust temp(°F; Actual value)	29	Frequency increase (Shift; Actual value)
09	Temp transform by pressure sensor (°F; Actual value)	30	△EV (step; Actual value)
10	IPM modular temp Tipm (°F; Actual value)	31	PFC control state
11	Target temp Ttrg (°F; Actual value)	32	Frequency limit item
12	Discharge temp superheat (°F; Actual value)	33	Driving failure code subdivision 1
13	Target superheat (°F; Actual value)	34	Driving failure code subdivision 2
14	Fan speed ( Actual value / 10)	35	Last failure or protection code
15	EXV opening degree (step; Actual value)	36	Software version number (1-255)
16	Pressure value (PSI; Actual value )	37	T7 condensing temp (°F; Actual value)
17	Pressure value transform by T3 (PSI; Actual value )	38	T30 temp (°F; Actual value)
18	AC voltage (VAC; Actual value )	39	Compression ratio
19	DC voltage (VDC; Actual value )		

# 14.11 Overview of Main Control Board

## Outdoor Main Control Board

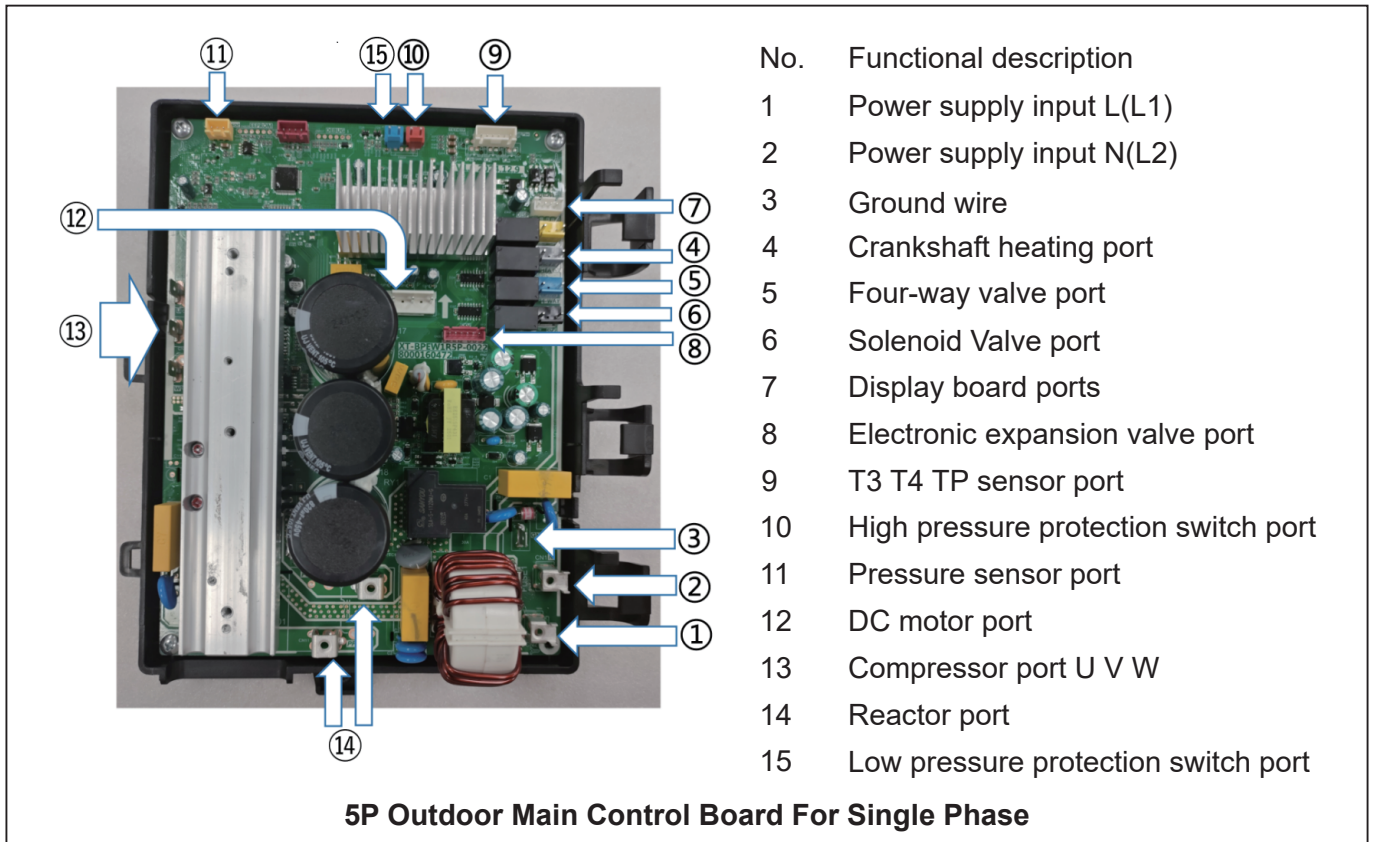

Figure 39

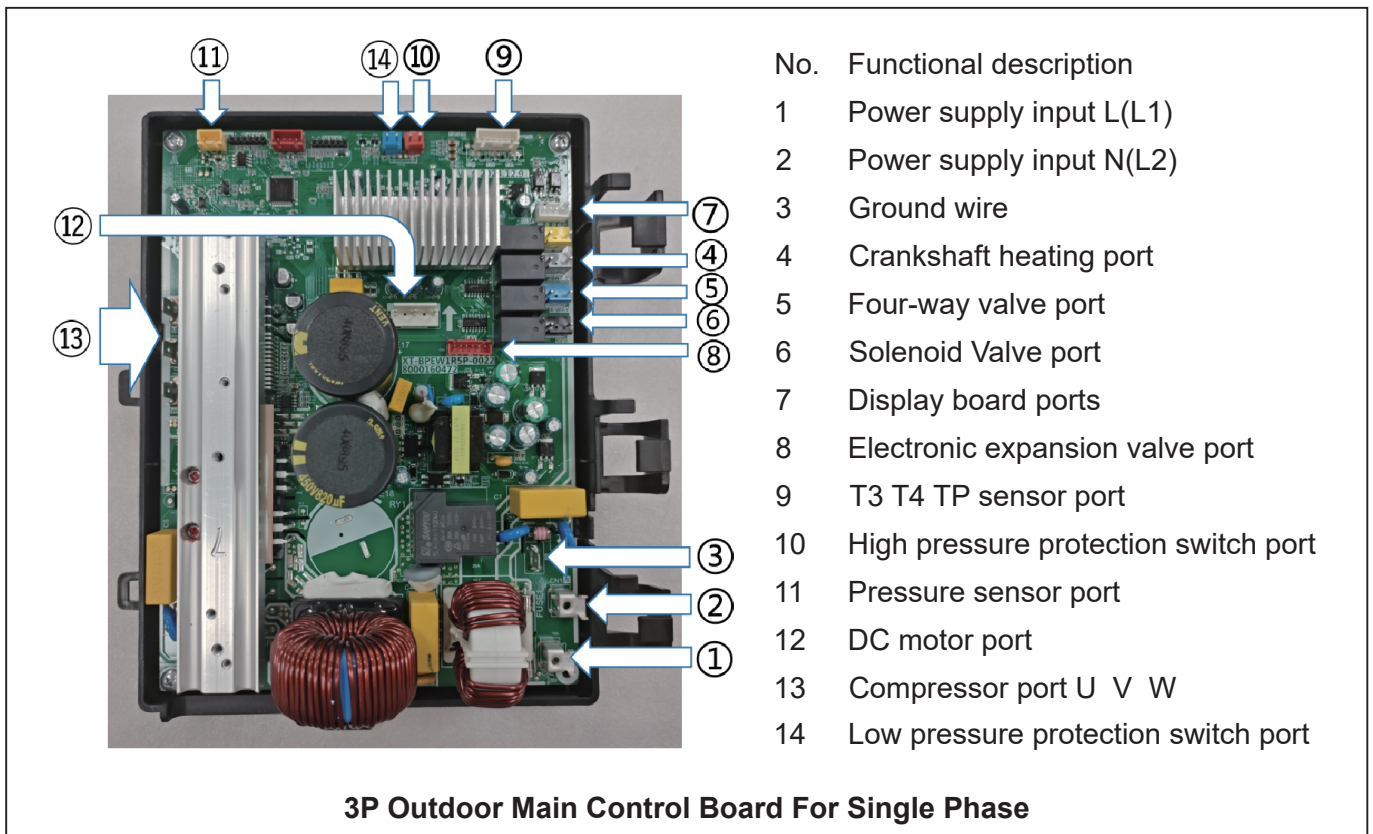

Figure 40

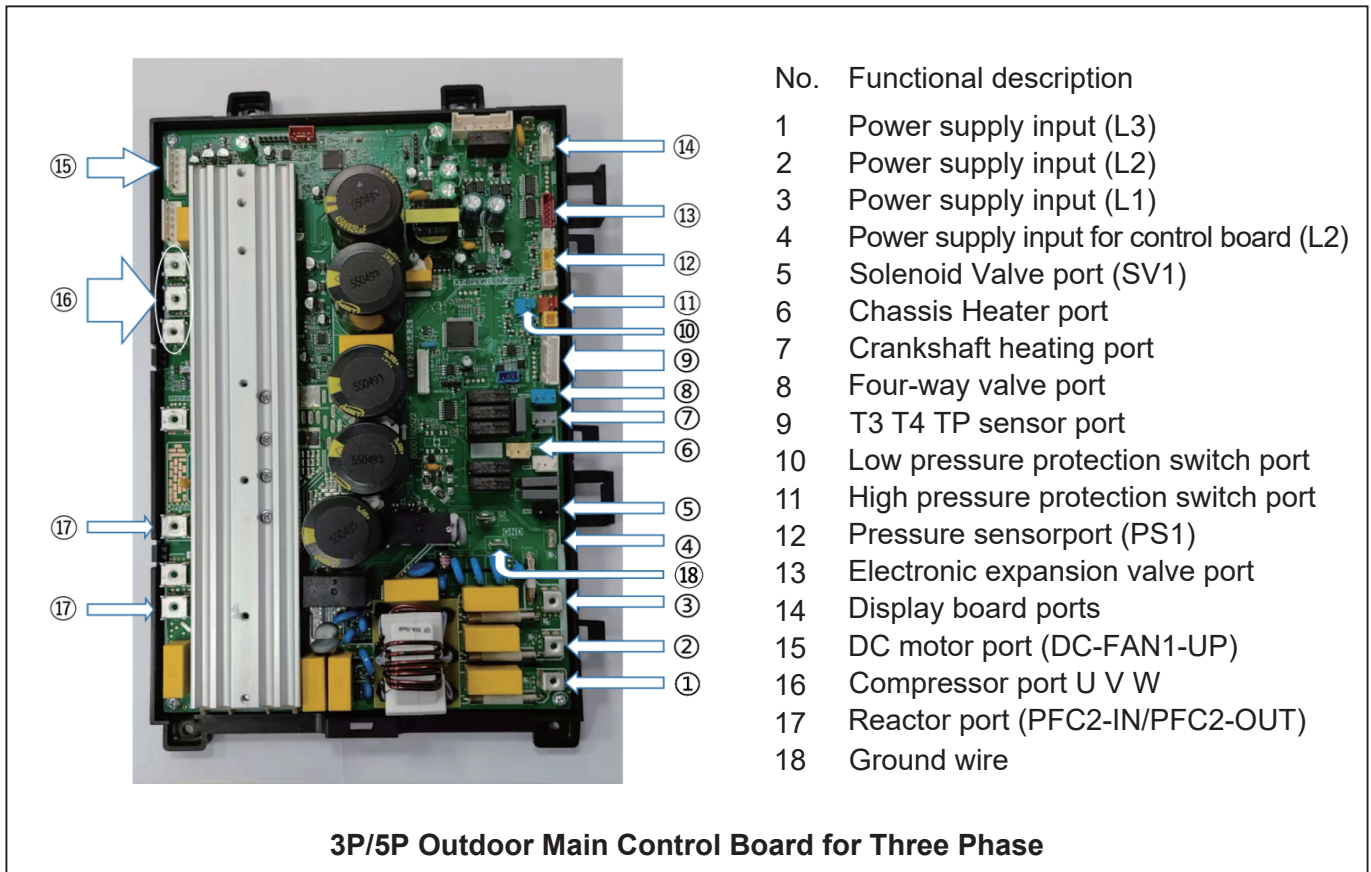

Figure 41

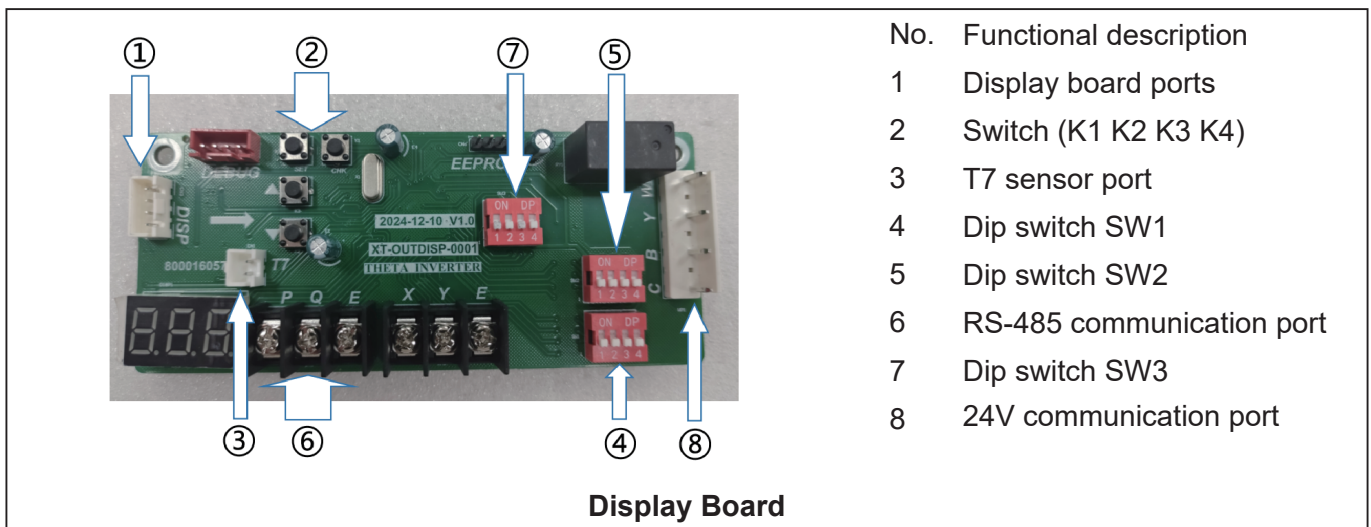

Figure 42

## Indoor Main Control Board

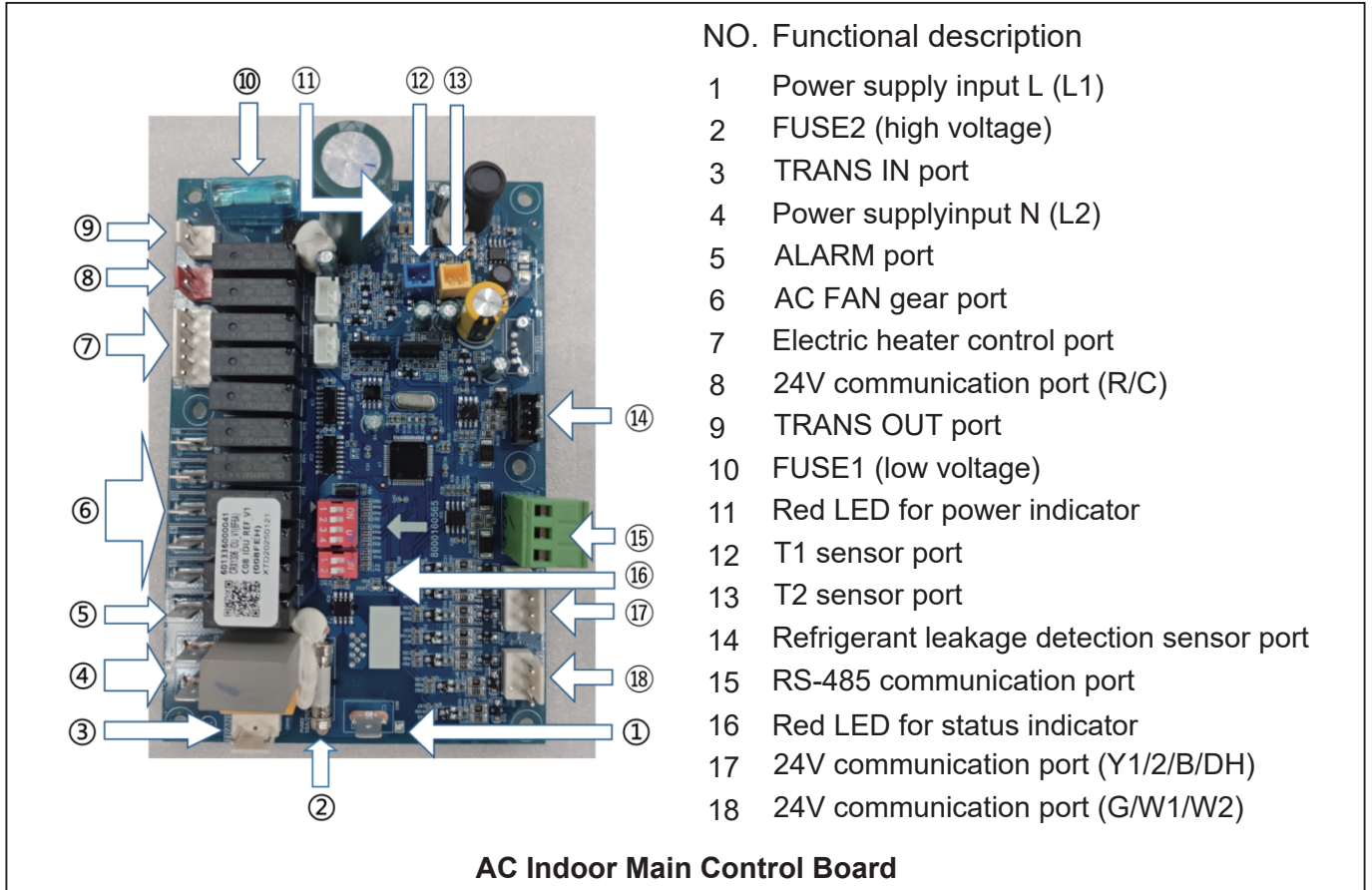

Figure 43

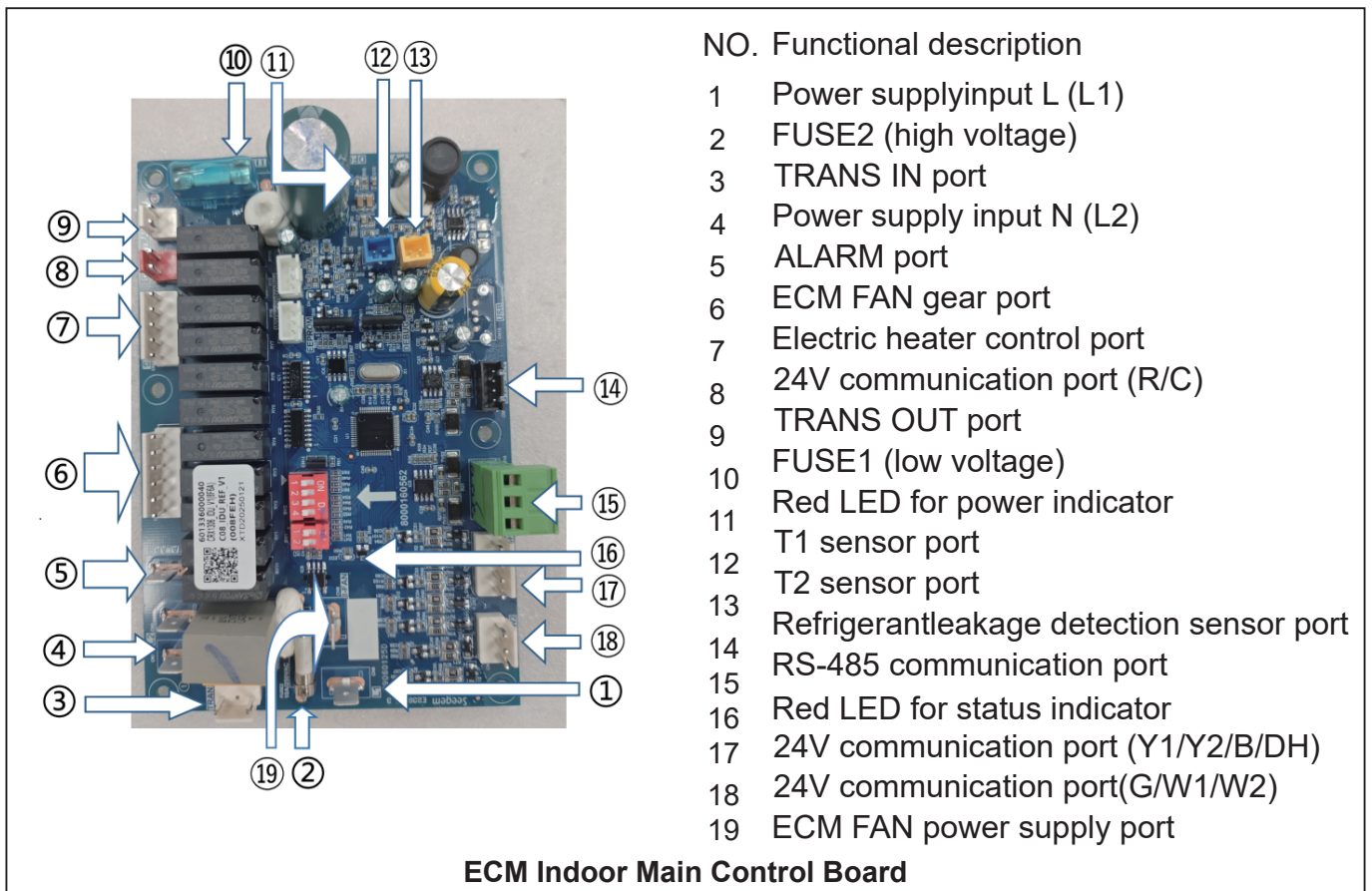

Figure 44

## 14.12 Troubleshooting of Fault Codes



### Warning: Dangerous voltage

- When measuring the resistance, make sure that the power of the unit is turned off and wait for 3 minutes before measuring.

#### F4 (T4 Outdoor ambient temp sensor failure)

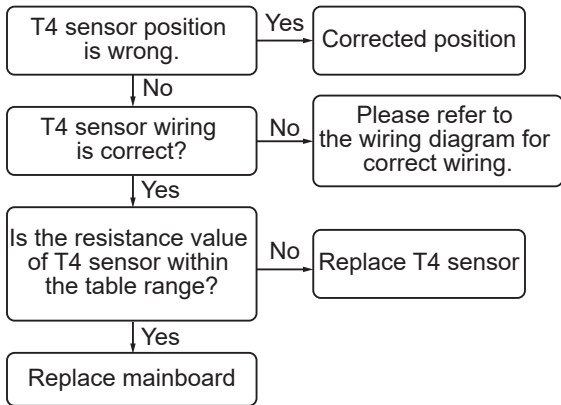

Figure 45

#### F6 (T3 Condenser temp sensor failure)

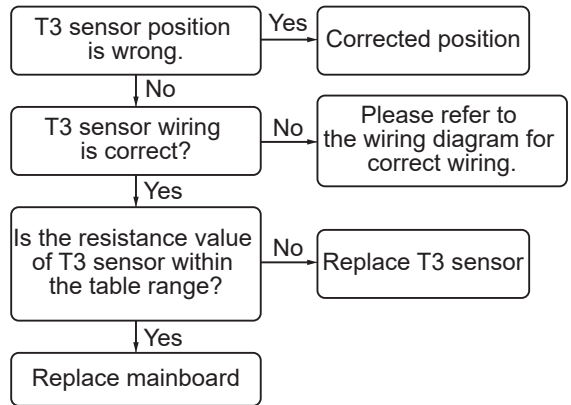

Figure 46

#### F5 (T5 Exhaust temperature sensor failure)

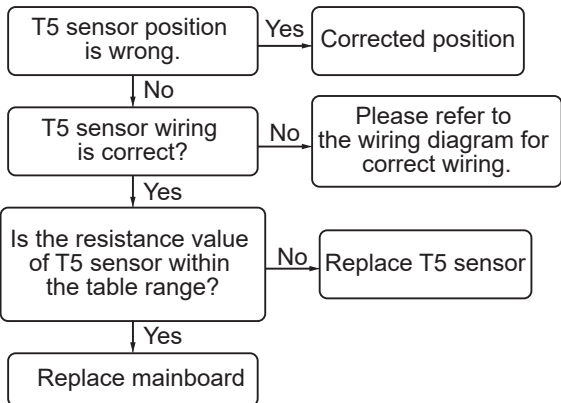

Figure 47

#### FC/H4/P8 (IPM module sensor failure, high temperature protection)

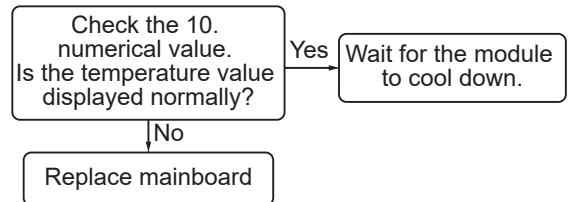

Figure 48

#### FD (HLP pressure sensor failure)

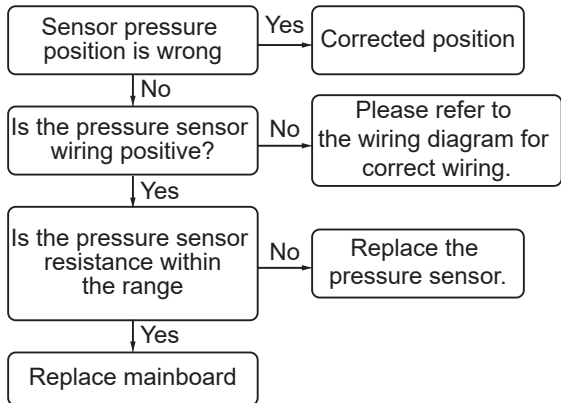

Figure 49

#### FE (T3 / T5 sensor is not tightly plugged in, and the unit stands by abnormally)

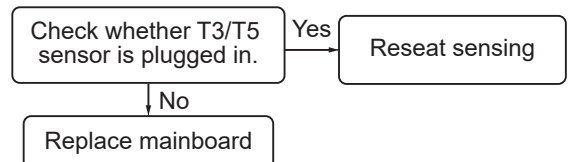
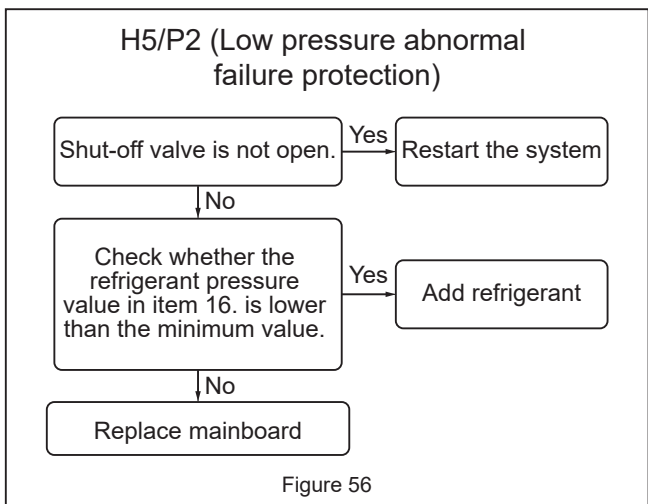
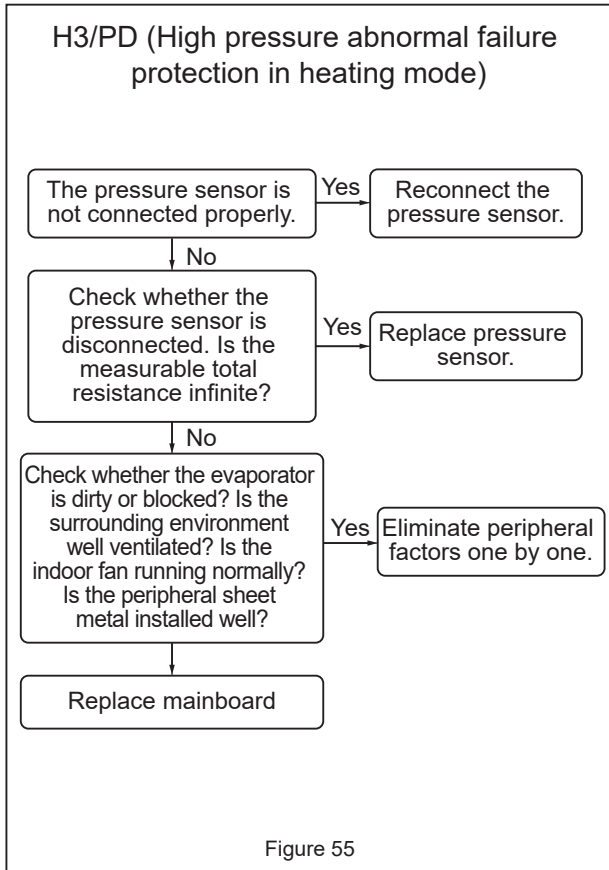
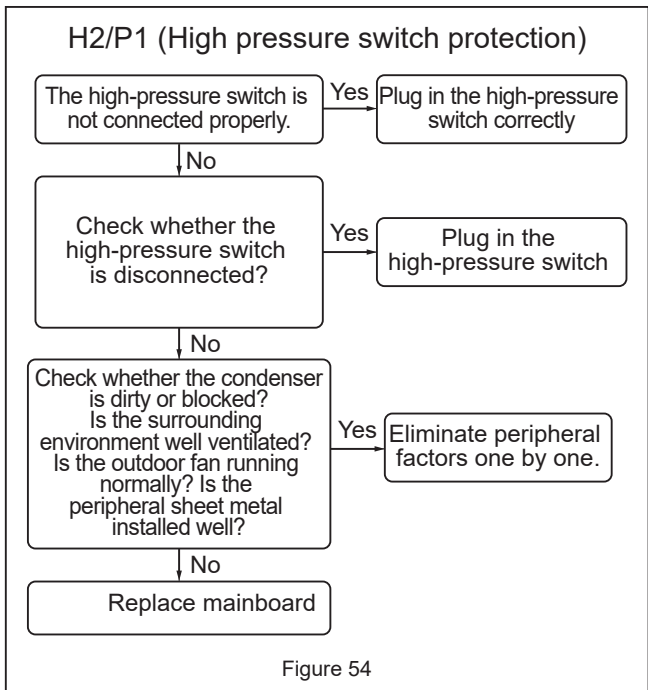
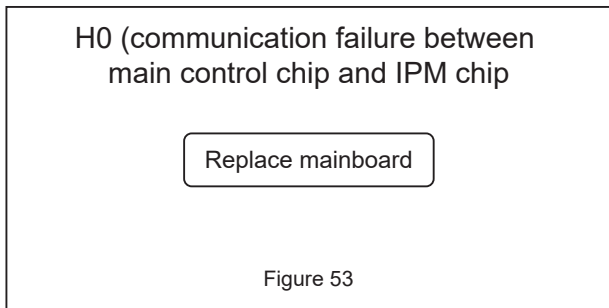
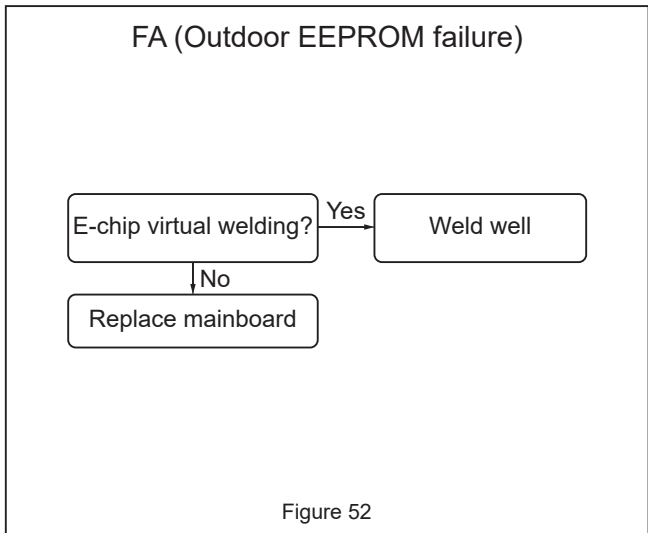
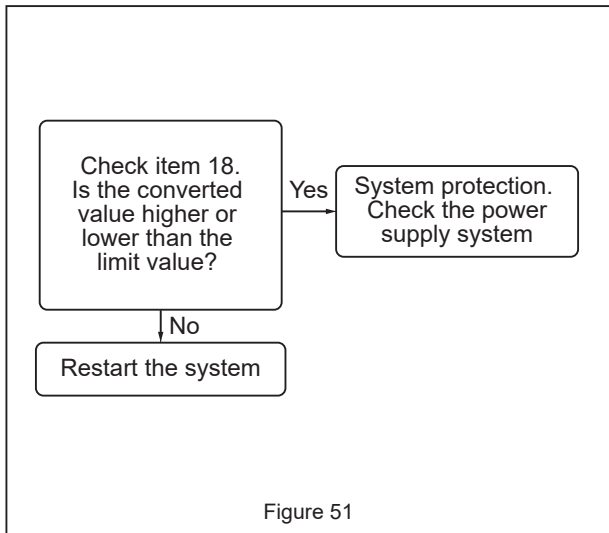
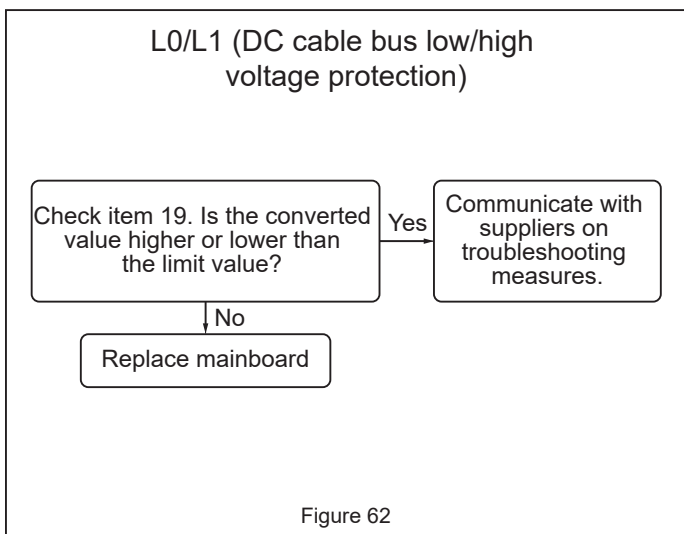
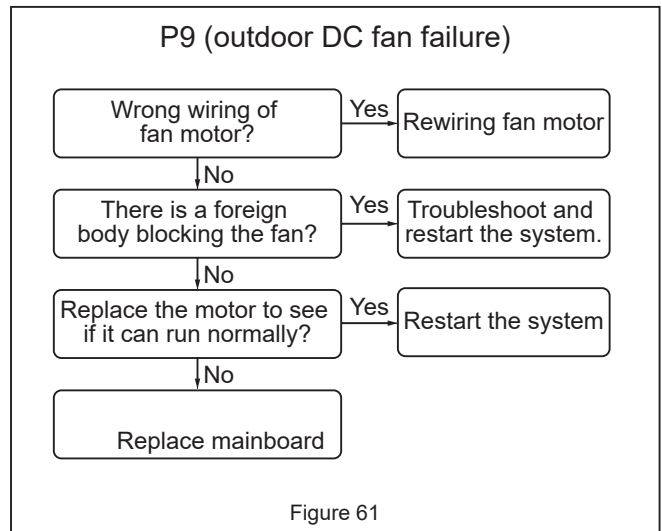
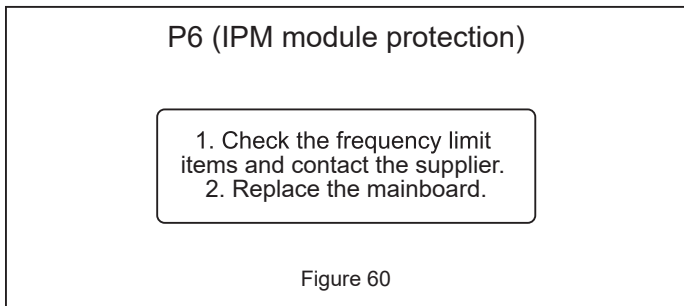
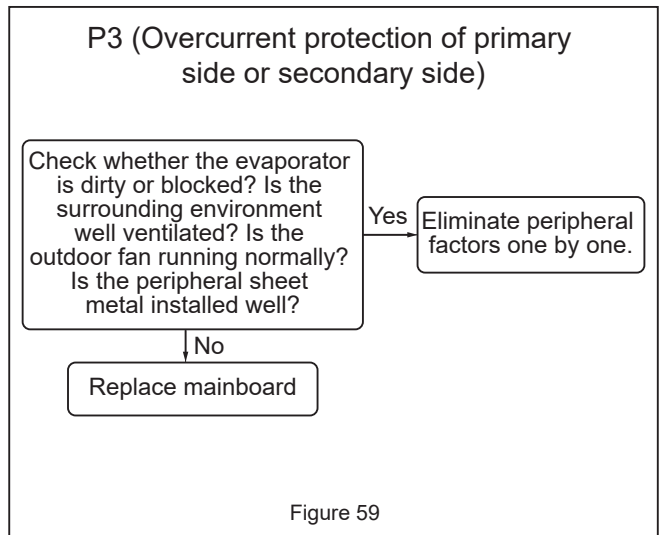
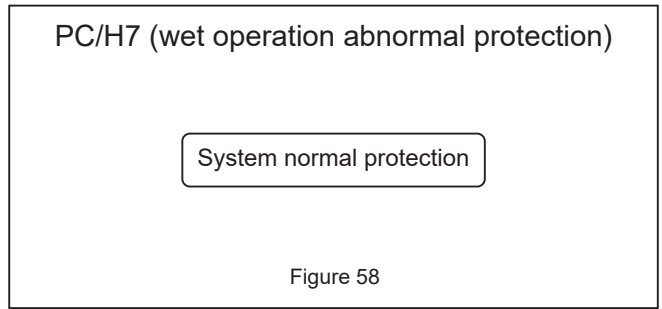
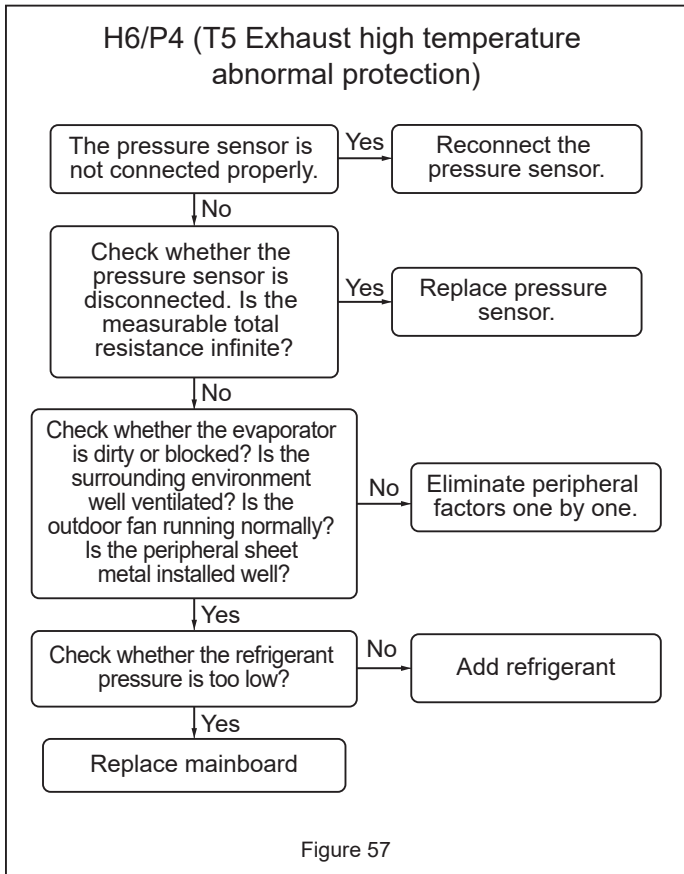

Figure 50





# 15 . Wiring Diagram

## 15.1 Wiring Diagram For ECM Indoor Fan Model(Single Phase)

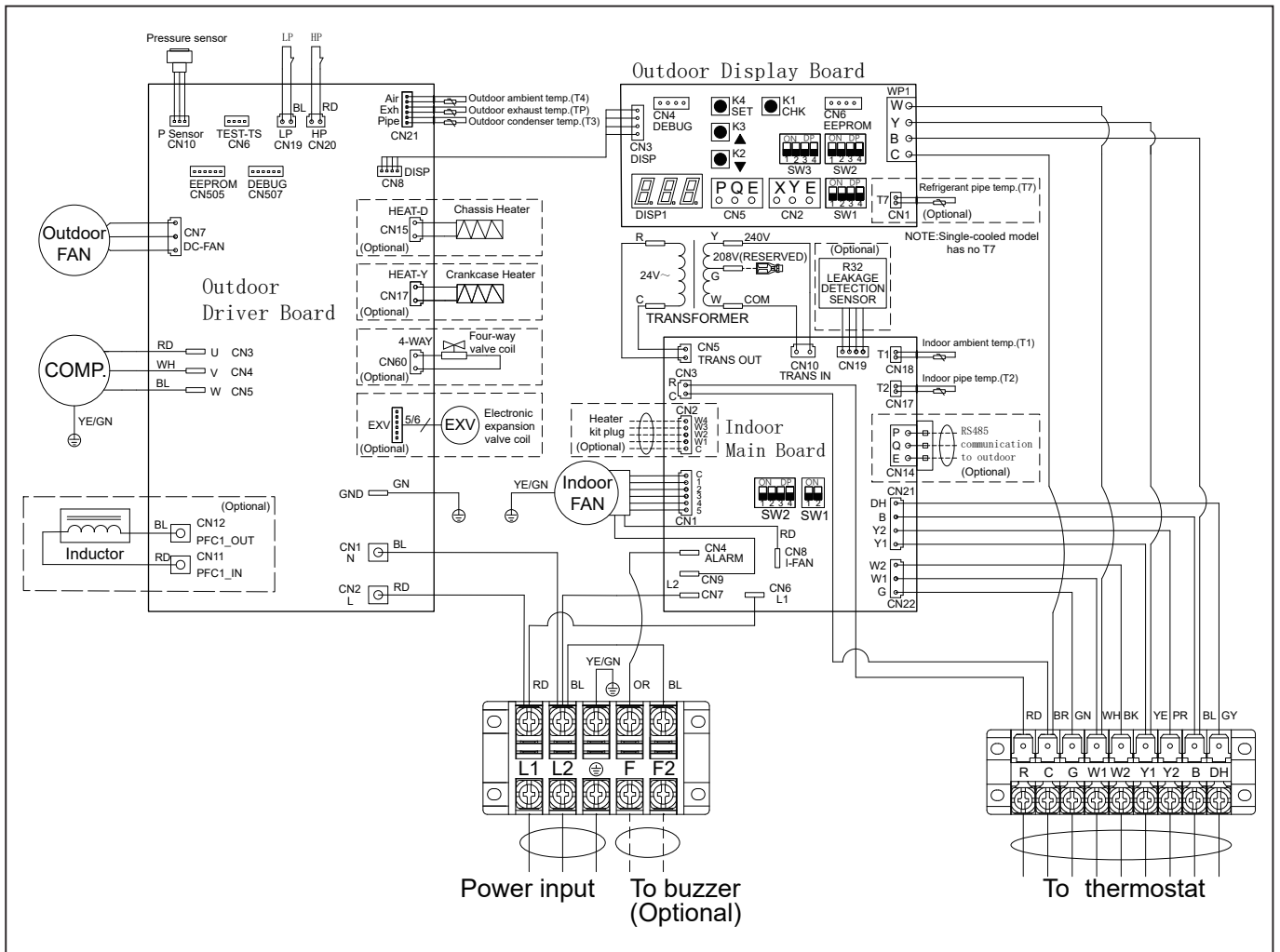

Figure 63

Wire Color Code	DIP switch status Indicate	Outdoor Display Board SW1 DIP switch selection	Outdoor Display Board SW2 DIP switch selection
RD RED OR ORANGE BL BLUE GN GREEN BR BROWN GY GRAY BK BLACK YE YELLOW WH WHITE PR PURPLE	ON <input type="checkbox"/> This Indicate OFF OFF <input checked="" type="checkbox"/> ( The DIP switch is dialed to the digital side) 1  ON <input checked="" type="checkbox"/> This Indicate ON OFF <input type="checkbox"/> ( The DIP switch is dialed to the non-digital side) 1	SW1.1 OFF 24V Control ON RS485 Comm. Mode SW1.2 OFF °F for Fahrenheit ON °C for Celsius SW1.3 OFF Heating and cooling ON Single-cooled SW1.4 OFF Normal Cooling ON Accelerate Cooling	SW2.1 OFF Auto Defrosting ON Periodically Defrosting SW2.2 OFF Defrost interval 60 minutes ON Defrost interval 30 minutes SW2.3 OFF Normal Defrosting ON Accelerate Defrosting SW2.4 OFF Normal Thermostat ON O/B Thermostat

Outdoor Display Board SW3 DIP switch selection				Indoor Main Board SW1 DIP switch selection (Indoor FAN speed)					Indoor Main Board SW2 DIP switch selection				
SW3.1	OFF	Normal energy efficiency			SW1.1	SW1.2	Model	High speed (Y1+Y2 OR W)	Low speed (Y1 OR G)	SW2.1	OFF	24V Control	
	ON	High energy efficiency ( SE18 )								SW2.1	ON	RS485 Comm. Mode	
SW3.2	OFF	SW3.3	OFF	Model	SW1.1	SW1.2	Model	High speed (Y1+Y2 OR W)	Low speed (Y1 OR G)	SW2.2	OFF	Anti-Cold Air Delay	
	OFF		ON							SW2.2	ON	Disable Anti-Cold Air Delay	
	ON		OFF							SW2.3	OFF	T1 from main board	
	ON		ON							SW2.3	ON	T1 from thermostat	
SW3.4	OFF	Normal Heating			SW1.1	SW1.2	Model	High speed (Y1+Y2 OR W)	Low speed (Y1 OR G)	SW2.4	OFF	Indoor AC FAN	
	ON	Accelerate Heating			ON	ON	36K / 60K	5	1	SW2.4	ON	Indoor ECM FAN	

Table 28

# 15.2 Wiring Diagram For AC Indoor Fan Model(Single Phase)

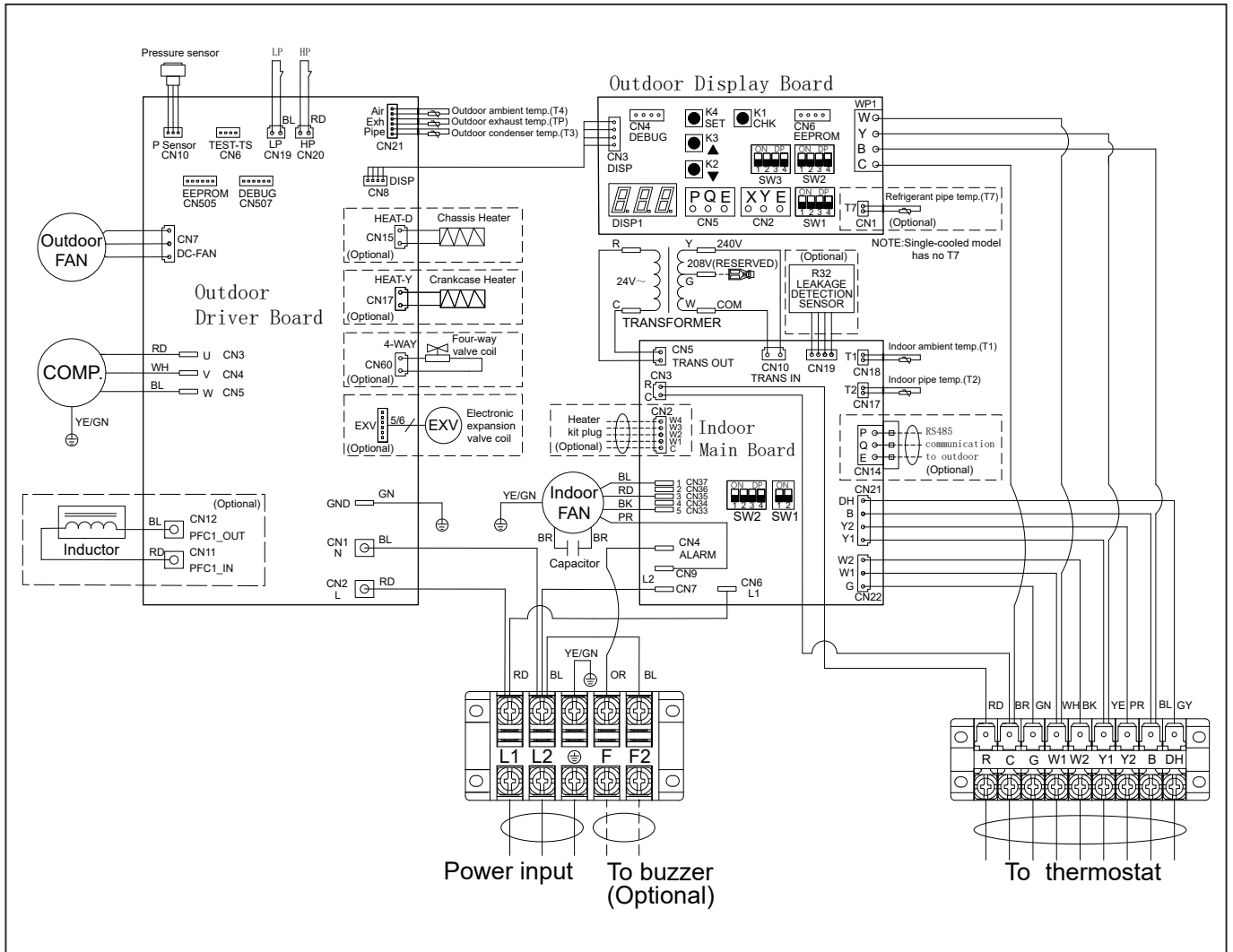

Figure 64

Wire Color Code	DIP switch status Indicate	Outdoor Display Board SW1 DIP switch selection	Outdoor Display Board SW2 DIP switch selection
RD RED OR ORANGE	ON <input type="checkbox"/> OFF <input checked="" type="checkbox"/> 1	SW1.1 OFF 24V Control ON RS485 Comm. Mode	SW2.1 OFF Auto Defrosting ON Periodically Defrosting
BL BLUE GN GREEN	ON <input checked="" type="checkbox"/> OFF <input type="checkbox"/> 1	SW1.2 OFF °F for Fahrenheit ON °C for Celsius	SW2.2 OFF Defrost interval 60 minutes ON Defrost interval 30 minutes
BR BROWN GY GRAY		SW1.3 OFF Heating and cooling ON Single-cooled	SW2.3 OFF Normal Defrosting ON Accelerate Defrosting
BK BLACK YE YELLOW	ON <input checked="" type="checkbox"/> OFF <input type="checkbox"/> 1	SW1.4 OFF Normal Cooling ON Accelerate Cooling	SW2.4 OFF Normal Thermostat ON O/B Thermostat
WH WHITE PR PURPLE			

Outdoor Display Board SW3 DIP switch selection				Indoor Main Board SW1 DIP switch selection (Indoor FAN speed)				Indoor Main Board SW2 DIP switch selection					
SW3.1	OFF	Normal energy efficiency			SW1.1	SW1.2	High speed (Y1+Y2 OR W)	Low speed (Y1 OR G)	SW2.1	OFF	24V Control		
	ON	High energy efficiency ( SE18 )							SW2.2	ON	RS485 Comm. Mode		
SW3.2	OFF	SW3.3	OFF	Model	SW1.1	SW1.2	2	1	SW2.2	OFF	Anti-Cold Air Delay		
	ON		ON						36K	ON	Disable Anti-Cold Air Delay		
	ON		OFF						48K	OFF	T1 from main board		
	ON		ON						60K	ON	T1 from thermostat		
SW3.4	OFF	Normal Heating			ON	OFF	4	1	SW2.3	OFF	Indoor AC FAN		
	ON	Accelerate Heating			ON	ON	5	1	SW2.4	ON	Indoor ECM FAN		

Table 29

# 15.3 Wiring Diagram For ECM Indoor Fan Model (Three Phase)

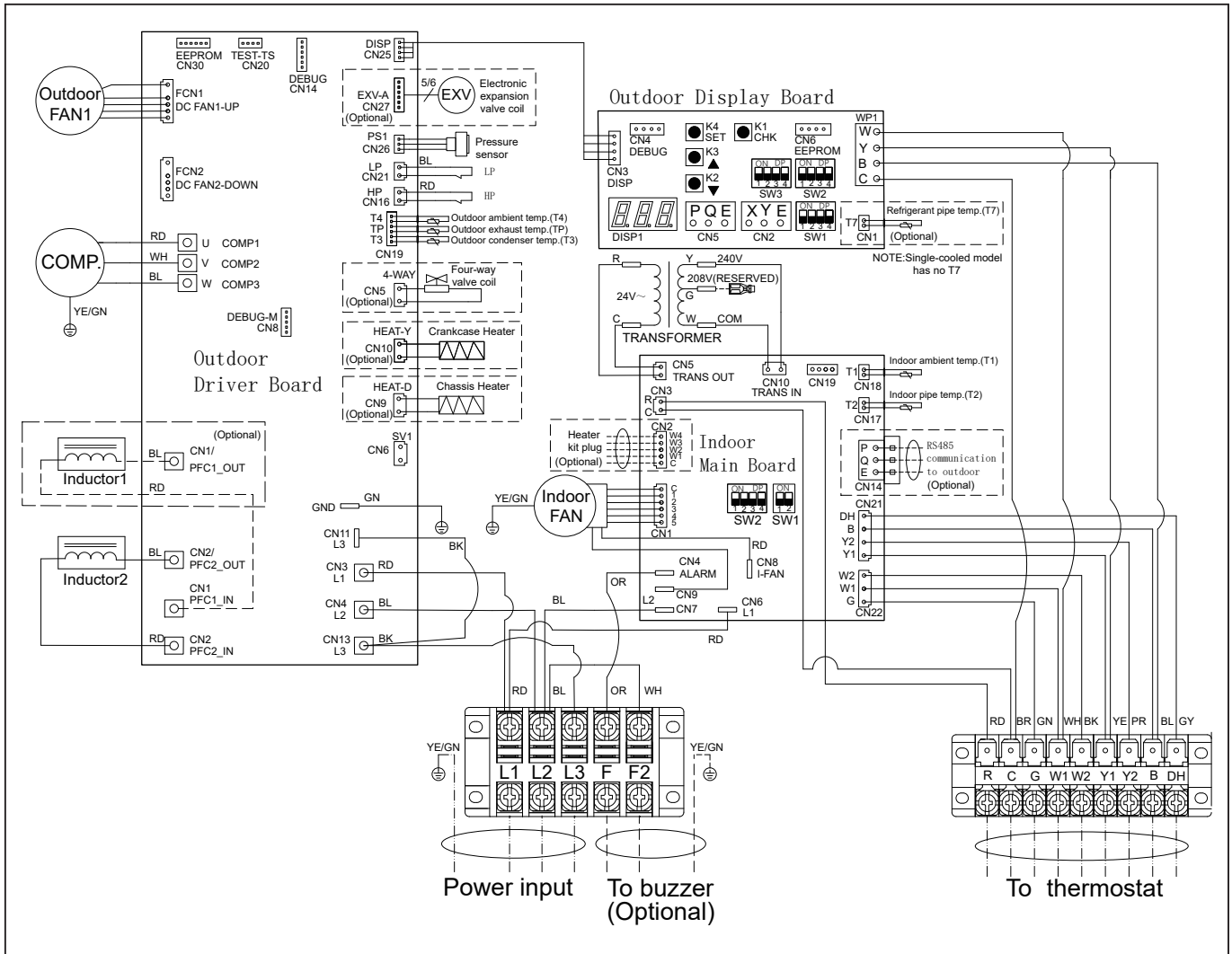

Figure 65

Line Annotation	Wire Color Code	DIP switch status Indicate	Outdoor Display Board SW1 DIP switch selection	Outdoor Display Board SW2 DIP switch selection
———— Factory wiring	RD RED OR ORANGE BL BLUE GN GREEN	ON <input type="checkbox"/> OFF <input type="checkbox"/> 1 This Indicate OFF ( The DIP switch is dialed to the digital side)	SW1.1 OFF 24V Control ON RS485 Comm. Mode(Default)	SW2.1 OFF Auto Defrosting(Default) ON Periodically Defrosting
- - - - Field wiring	BR BROWN GY GRAY	ON <input type="checkbox"/> OFF <input type="checkbox"/> 1 This Indicate ON ( The DIP switch is dialed to the non-digital side)	SW1.2 OFF °F for Fahrenheit(Default) ON °C for Celsius	SW2.2 OFF Defrost interval 60 minutes(Default) ON Defrost interval 30 minutes
- - - - Field wiring (Optional)	BK BLACK YE YELLOW WH WHITE PR PURPLE		SW1.3 OFF Heating and cooling ON Single-cooled	SW2.3 OFF Normal Defrosting(Default) ON Accelerate Defrosting
			SW1.4 OFF Normal Cooling(Default) ON Accelerate Cooling	SW2.4 OFF Normal Thermostat(Default) ON O/B Thermostat

Outdoor Display Board SW3 DIP switch selection				Indoor Main Board SW1 DIP switch selection (Indoor FAN speed)				Indoor Main Board SW2 DIP switch selection												
SW3.1	OFF	Normal energy efficiency			SW1.1	SW1.2	Model	High speed (Y1+Y2 OR W)	Low speed (Y1 OR G)	SW2.1	OFF	24V Control(Default)								
	ON	High energy efficiency ( SE18 )									ON	RS485 Comm. Mode								
SW3.2	OFF	SW3.3	OFF	Model	SW1.1	SW1.2	Model	High speed (Y1+Y2 OR W)	Low speed (Y1 OR G)	SW2.2	OFF	Anti-Cold Air Delay(Default)								
	ON		ON								24K	OFF	Disable Anti-Cold Air Delay							
	ON		OFF								48K	OFF	ON	24K	3	1	OFF	T1 from main board(Default)		
	ON		ON								60K	ON	OFF	48K	4	1	ON	T1 from thermostat		
SW3.4	OFF	Normal Heating(Default)			SW1.1	SW1.2	Model	High speed (Y1+Y2 OR W)	Low speed (Y1 OR G)	SW2.4	OFF	Indoor AC FAN								
	ON	Accelerate Heating									ON	ON	36K 60K	5	1	ON	Indoor ECM FAN(Default)			

Table 30

## 16 . Cleaning and Maintenance

### 16.1 Cleaning Precautions

#### Warning:



- Any maintenance and cleaning of outdoor units can only be carried out by qualified maintenance personnel.
- Any unit maintenance can only be carried out by qualified maintenance personnel.



#### Caution: Electric shock

- Be sure to turn off the unit and disconnect the power supply before cleaning or maintenance.



#### Note:

- Do not use chemicals or chemically treated cloth to clean the unit.
- Do not use benzene, paint thinner, polishing powder or other solvents to clean this unit.



#### Be careful:

- When removing the filter, do not touch the metal parts in the unit. Sharp metal edges can cut you.

### 16.2 Pre-Season Inspection and Maintenance

At the start of each heating or cooling season, do the following:



Turn off the unit and disconnect the power supply.



Check for damaged wires, check for leaks.



Make sure that all air inlets and outlets are not blocked.

Table 31